



# CG938H 轮式装载机

MODEL CG938H WHEEL LOADER

## 零件目录

PARTS CATALOGUE

四川成都成工工程机械股份有限公司

SICHUAN, CHENGDU CHENGGONG CONSTRUCTION MACHINERY CO., LTD.

# 零件目录使用说明

本零件目录包括 CG938H 型轮式装载机的零、部件，按照装配使用位置作了详细的标注和说明。

## 1.零件目录的使用

1.1 所需的零部件，先在图册上找到它的位置，查出它的序号，然后在对应的目录表上找到相应序号的那一格，即可查出所需零部件的代号、名称和每台机器所需的数量。

1.2 一部分组合件没有分别画出所属零件，只标以组合件。

1.3 本零件目录使用了左右位置，均按机器前进方向作基准来区别左右方向。

1.4 目录表中所列数量，是指每台机器装配时应有的件数。

1.5 注：

组——必要时使用体积、厚度或数量加以对照；

△——没有进行图示的零部件；

GB——中国国家标准；

JB——中国机械工业部标准。

## 2.订购零部件

凡订购本公司机器的零部件时请提供下列说明：

1.写明机器的型号、出厂编号和出厂日期；

2.写明所订零部件的代号、名称、实际所需数量。

## 3.注意事项

3.1 更换零部件时，除标准件、外购件外，务必使用本公司机器的零部件，而不要随意使用其它产品零部件，以防止机器遭受严重损坏后不能更换使用。

3.2 产品的结构和性能在不断改进和提高，本零件目录的内容可能会与出厂产品实际结构稍有差异，除较大变动要补充说明外，一般均在新版时进行修改，请用户在使用时加以注意。

# INSTRUCTIONS FOR THE USE OF

## THE PARTS CATALOGUE

All the parts of CG938H Wheel Loader, marked and described in detail, are included in this parts catalogue.

### 1. The use of parts catalogue

1.1 First, check up the required parts which are marked by sign number from the figure. Then, in accordance with this sign number, you can the part's code No., name and quantity for each machine from the parts catalogue table.

1.2 Some assemblies are not given the all parts but only the assemble themselves.

1.3 The direction of right or left used in this parts catalogue is accordance with the forward direction of the machine.

1.4 The quantity on the parts catalogue table is the possessive quantity for the use of each machine.

1.5 Note:

Group-to contrast with volume, thickness and quantity when it is necessary.

△-The parts does not show in figure.

GB-Chinese standard.

JB-Standard of the First Machine-Building Ministry of China.

### 2. Order the spare parts

Those who order the spare parts should give the detail contents described below.

1. The model of the grader、 the number of manufacture and date production.

2. The code No., the name and required quantity of the parts.

### 3. Attention

3.1 When the parts of the grader need replace, you have to replace them with the parts made by our work. In order to prevent the machine from damage, don't' use the parts of other to vehicle to substitute for with exception of the standard-parts.

3.2 The construction of the grader will be given some improvements after a certain period time. So there will be some differences in the parts catalogue.

# 目 录

## Contents

发动机装置 .....	5
Engine Assembly	
变矩器变速箱 .....	16
Torque Converter Transmission	
变速油路及操纵系统 .....	19
Transmission Oil Line And Control	
前桥、后桥 .....	21
Front Axle & Rear Axle	
前传动轴 .....	38
Front Driving Shaft	
转向系统 .....	41
Steering System	
制动系统 .....	57
Braking System	
工作液压系统 .....	74
Implement Hydraulic System	
后传动轴 .....	102
Rear Drive Shaft	
车身车架 .....	105
Frame Group	
驾驶室 .....	116
Cab	
工作装置 .....	127
Implement	
电气设备 .....	134
Electrical Apparatus	
找平装置 .....	146
Level Device	
空调系统 .....	152
Air-conditioner System	
风扇控制系统 .....	156
Fan Control System	
提升臂架支承装置 .....	161
Safety Support Of Lift Cylinder	
手动集中润滑油路系统 .....	164
Manual Generalized Lubricating System	

# 发动机装置

## Engine Assembly

# Z38G01 发动机装置 Engine Assembly

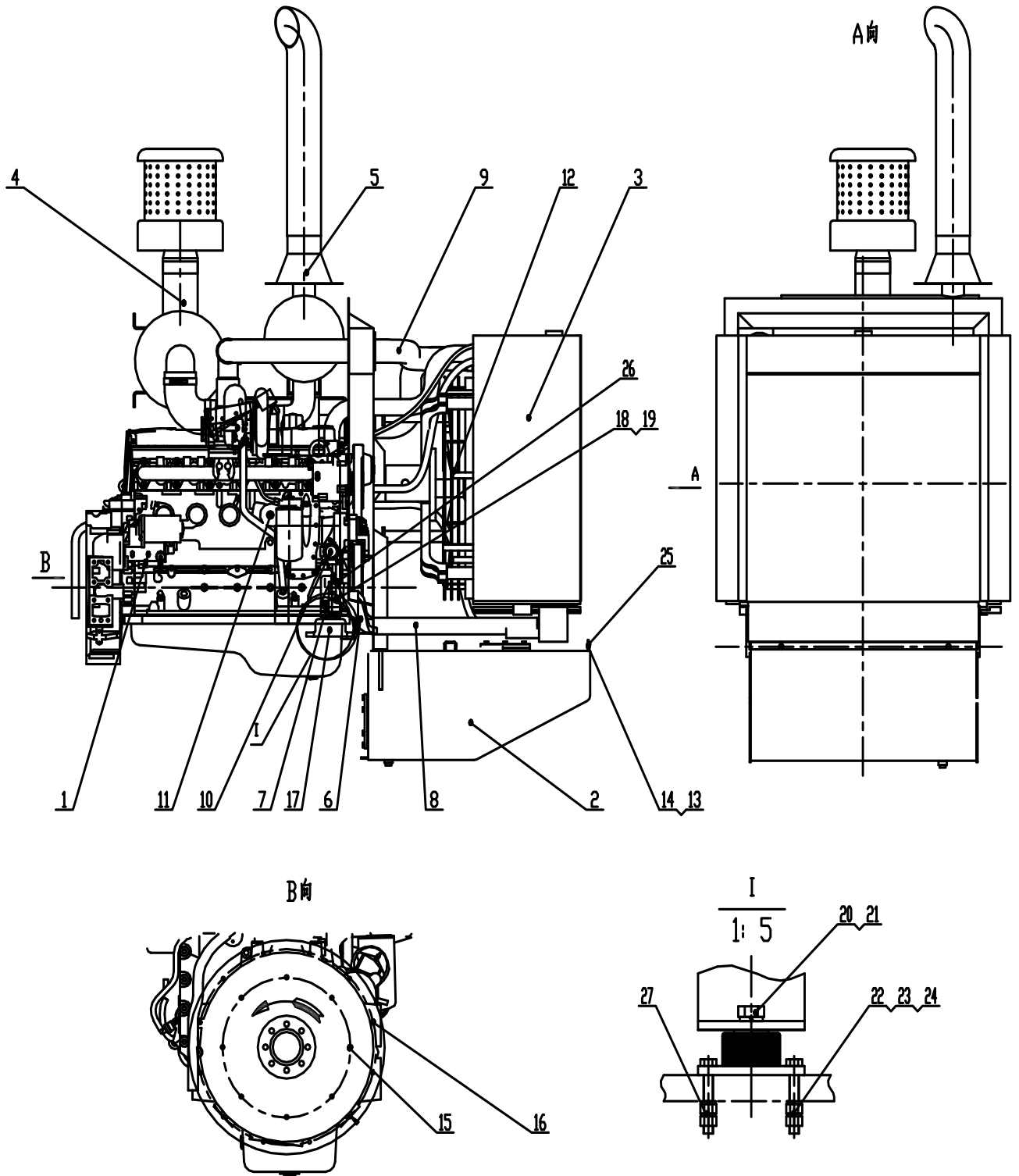

## Z38G01 发动机装置 Engine Assembly

序号 Item	代号 Part No.	名 称 Parts Name	数量 Q'ty	备注 Remark	
1	QSB6.7(F-CG35-QSB6.7)	柴油机	Diesel Engine	1	
2	Z38G0101	燃油箱总成	Fuel Tank Assembly	1	
3	Z38G0102	冷却系统	Cooling Assembly	1	
4	Z38G0103	进气系统	Admission Assembly	1	
5	Z38G0104	排气装置	Exhaust Assembly	1	
6	Z50G0107T17	进回油管路	Inlet Oil Hose Assembly		
7	Z35G0110T4	柴油机后支架(左)	Back Support	1	
8	Z38G0105	进水管总成	Inlet Hose Assembly	1	
9	Z38G0106	回水管总成	Outlet Hose Assembly	1	
10	Z50G010000001T7	取暖回水管接头	Tie_Out Warm Water Pipe	1	
11	Z50G010000002T7	取暖进水管接头	Tie_in Warm Water Pipe	1	
	711/9-9/32.5° /PAG/2ZR/6				
12	0/5x8.5/BC90A	风扇	Fan	1	
13	GB/T5783-2000	螺栓 M10X30	Bolt M10X30	6	
14	GB/T93-1987	垫圈 10	Washer 10	18	
15	3/8X18.5-16	螺栓	Bolt	8	
16	GB/T5783-2000	螺栓 M10X40	Bolt M10X40	12	
17	EA400	减震垫	Damper	2	
18	GB/T5783-2000	螺栓 M12X35	Bolt M12X35	6	
19	GB/T93-1987	垫圈 12	Washer 12	6	
20	GB/T5782-2000	螺栓 M27X50	Bolt M27X50	2	
21	GB/T93-1987	垫圈 27	Washer 27	2	
22	GB/T5782-2000	螺栓 M14X75	Bolt M14X75	8	
23	GB/T93-1987	垫圈 14	Washer 14	8	
24	GB/T6170-2000	螺母 M14	Nut M14	16	
25	GB/T97.1	垫圈 10	Washer 10	18	
26	GB/T97.1	垫圈 12	Washer 12	6	
27	GB/T97.1	垫圈 14	Washer 14	8	

# Z38G0101 燃油箱总成 Fuel Tank Assembly

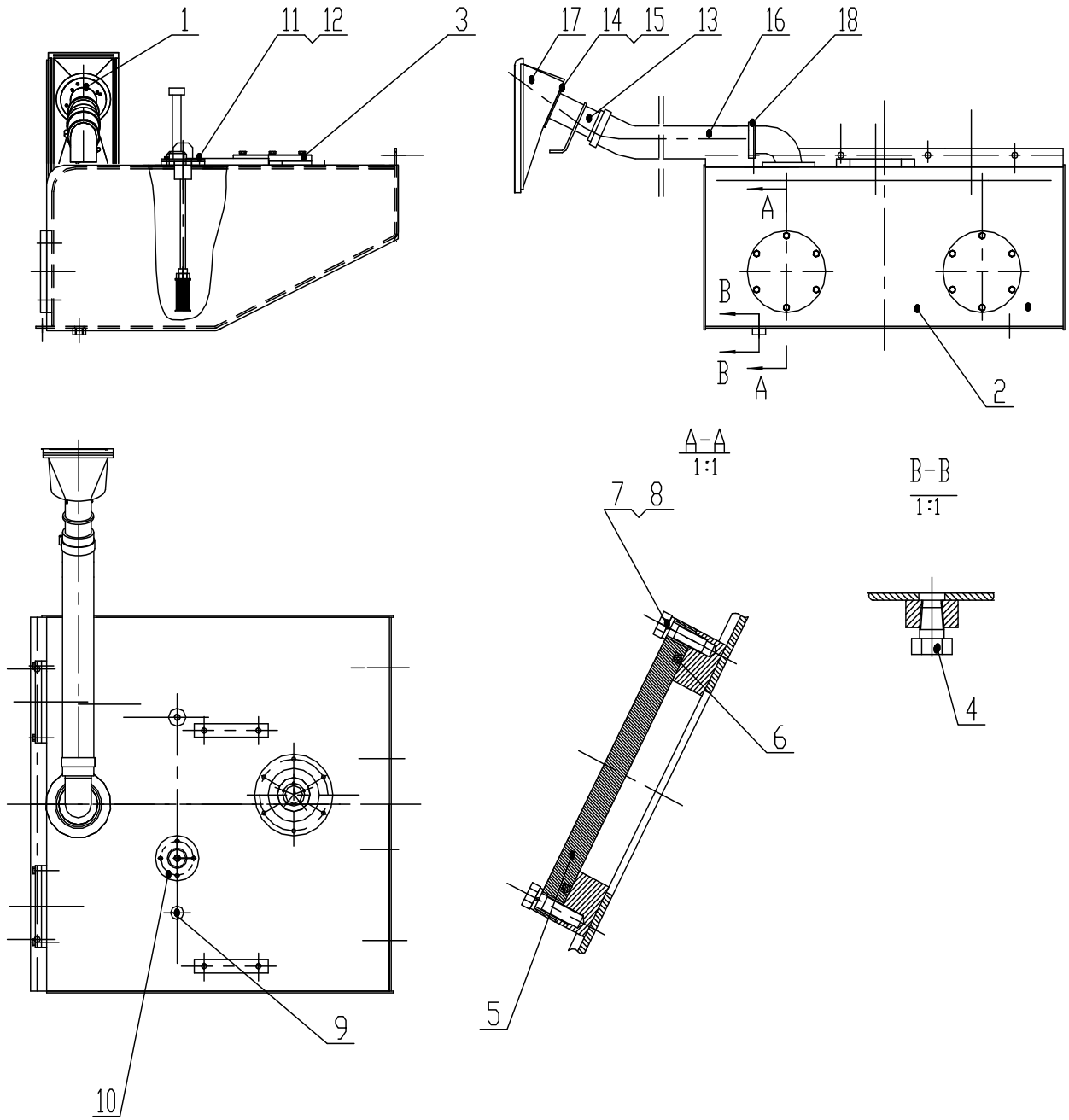



## Z38G0101 燃油箱总成 Fuel Tank Assembly

序号 Item	代号 Part No.	名 称 Parts Name	数量 Q'ty	备注 Remark
1	TK50C	空气滤清器 Air Cleaner	1	
2	Z38G010101	燃油箱体 Tank Body	1	
3	Z35C010100001	连接法兰 Jioned Flange	1	
4	ZL30B. 1. 1-10	放油塞 Thread Plug	1	
5	ZL30B. 1. 1-2	发兰盘 Flange	2	
6	GB/T3452. 1-1982	O型圈132X2. 65 O-Ring 132X2. 65	2	
7	GB/T5783-2000	螺栓M8X25 Bolt M8X25	18	
8	GB/T93-1987	垫圈8 Washer 8	18	
9	LG-ZL50-13A	呼吸螺塞 Breath Plug	1	
10	Z38G010102	吸油管总成 Suck Vitta Assembly	1	
11	GB/T93-1987	垫圈5 Washer 5	4	
12	GB/T5783-2000	螺栓M5X20 Bolt M5X20	4	
13	Z50G010103T17	焊接管总成 Jionting Pipe Assembly	1	
14	GB/T70. 1-2000	螺栓M8X12 Bolt M8X12	4	
15	GB/T93-1987	垫圈8 Washer 8	4	
16	Z38G010100002	胶管 Collloid Pipe	1	
17	Z38G010100001	胶套 Collloid Knot	1	
18	Φ 65- Φ 75	卡箍 Clip	2	

## Z38G0102 冷却系统 Cooling Assembly

A向

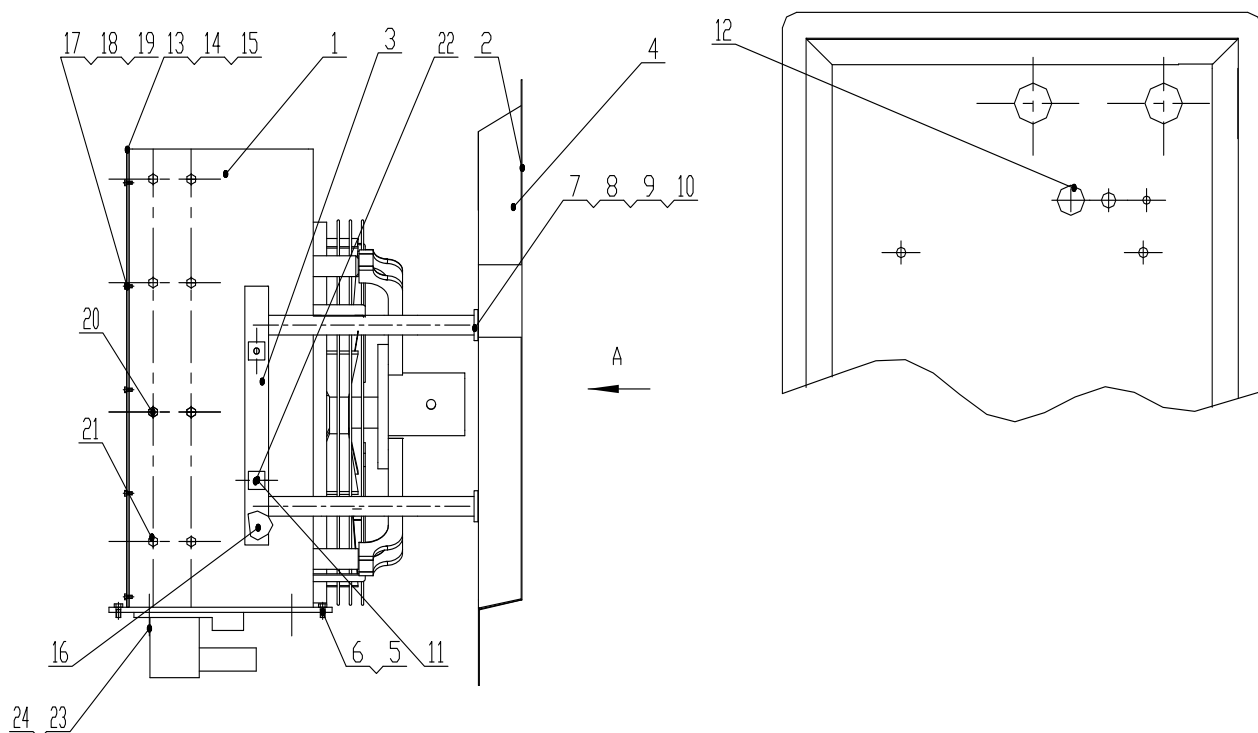

## Z38G0102 冷却系统 Cooling Assembly

序号 Item	代号 Part No.	名 称 Parts Name	数量 Q'ty	备注 Remark
1	Z38G010204	水箱总成 Water Tank Assembly	1	
2		密封橡胶条 Rubber Bar	4米	
3	Z38G010201	支架结合组 Support Assembly	1	
4	Z38G010202	隔板组件 Clapboard Assembly	1	
5	GB/T93-1987	垫圈12 Washer 12	20	
6	GB/T5783-2000	螺栓M12X40 Bolt M12X40	4	
7	GB/T5783-2000	螺栓M10X20 Bolt M10X20	28	
8	GB/T93-1987	垫圈10 Washer 10	12	
9	GB/T6170-2000	螺母 M10 Nut M10	24	
10	GB/T955-2000	垫圈10 Washer 10	8	
11	GB/T70.1-2000	螺栓M10X25 Bolt M10X25	4	
12	Z38G010200003	橡胶护套 Collloid Knot	1组	
13	Z38G010200004	板一 Board One	2	
14	Z38G010200005	板二 Board Two	2	
15		球头密封胶条 Rubber Bar	2米	
16	Z38G010203	支架结合组二 Support Assembly Two	1	

## Z38G0102 冷却系统 Cooling Assembly

序号 Item	代号 Part No.	名 称 Parts Name	数量 Q'ty	备注 Remark
17	GB/T 5783-2000	螺栓M8X15 Bolt M8X15	20	
18	GB/T93-1987	垫圈8 Washer 8	20	
19	GB/T97.1-2000	垫圈8 Cushion 8	20	
20	GB/T 5783-2000	螺栓M12X25 Bolt M12X25	16	
21	GB/T97.1-2000	垫圈12 Cushion 12	20	
22	GB/T97.1-2000	垫圈10 Cushion 10	28	
23	GB/T 5783-2000	螺栓M8X20 Bolt M18X20	4	
24	GB/T97.1-2000	垫圈8 Cushion 8	4	

## Z38G0103 进气系统 Admission Assembly

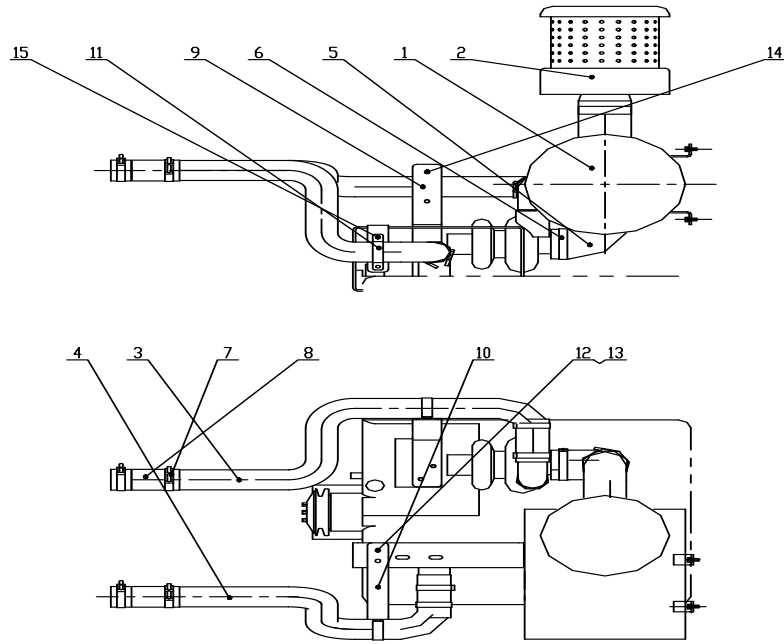

## Z38G0103 进气系统 Admission Assembly

序号 Item	代号 Part No.	名 称 Parts Name	数量 Q'ty	备注 Remark
1	A927	空气滤清器 Air Cleaner	1	
2	KA50-5	空气预滤器 Air Beforehand Cleaner	1	
3	Z38G010301	中冷器进气管I Inlet Gas Pipe Of Middle Cooling I	1	
4	Z38G010302	中冷器进气管II Inlet Gas Pipe Of Middle Cooling II	1	
5	Z50G010300001T7	进气胶管 Inlet Gas Colloid Pipe	1	
6	Φ130-Φ140	卡箍 Clamp	2	
7		卡箍 Clamp	8	
8	IC9288	硅胶管 Silica Gel Pipe	4	
9	Z38G010300002	支架一 Bracket one	1	
10	Z38G010300001	支架 Bracket	1	
11	Z50G010300003T17	夹子 Clip	2	
12	GB/T 5783-2000	螺栓M10X25 Bolt M10X25	12	
13	GB/T93-1987	垫圈10 Washer 10	12	
14	GB/T6170-2000	螺母 M10 Nut M10	8	
15	GB/T97.1-2000	垫圈10 Cushion 10	12	

Z38G0104 排气装置 Exhaust Assembly

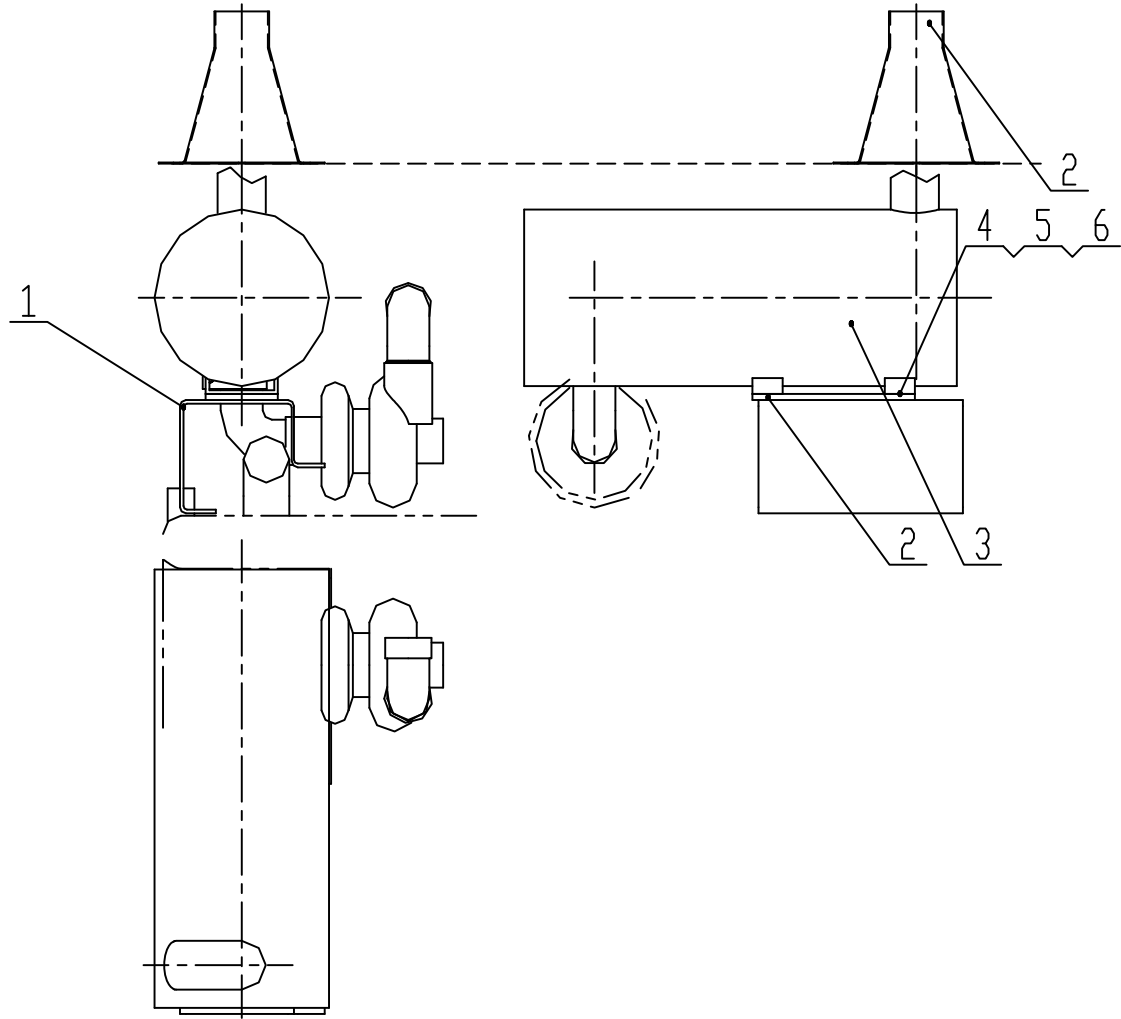

Z38G0104 排气装置 Exhaust Assembly

序号 Item	代号 Part No.	名 称 Parts Name	数量 Q'ty	备注 Remark
1	Z50G010400001T17	支架 Bracket Support	1	
2	Z35G010400002T4	垫板 Cushion	1	
3	XH.G503X.W	消声器 Muffler	1	
4	GB/T5783-2000	螺栓 M10×25 Bolt M10×25	15	
5	GB/T6170-2000	螺母 M10 Nut10	2	
6	GB/T93-1987	垫圈 10 Washer 10	15	
7	Z38G010401	排气尾管总成 Bolt M10×25	15	

Z38G0105 进水管总成 Inlet Water Pipe Assembly

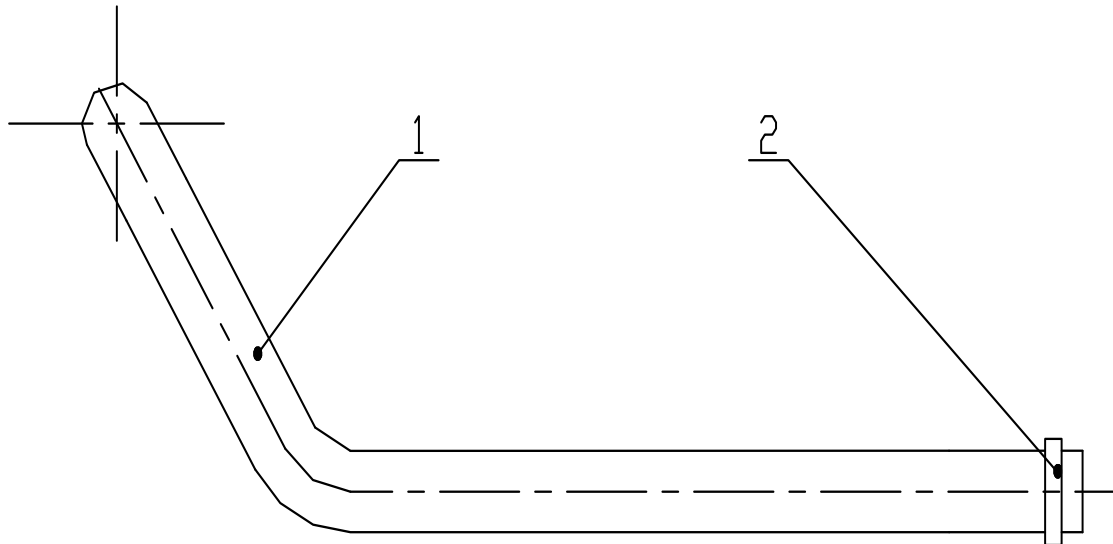

Z38G0105 进水管总成 Inlet Water Pipe Assembly

序号 Item	代号 Part No.	名 称 Parts Name		数量 Q'ty	备注 Remark
1	Z38G010500001	进水胶管	Innet Water Pipe	1	1
2	Φ50-Φ60	卡箍	Clam	2	2

Z38G0106 回水胶管总成 Outlet Water Pipe Assembly

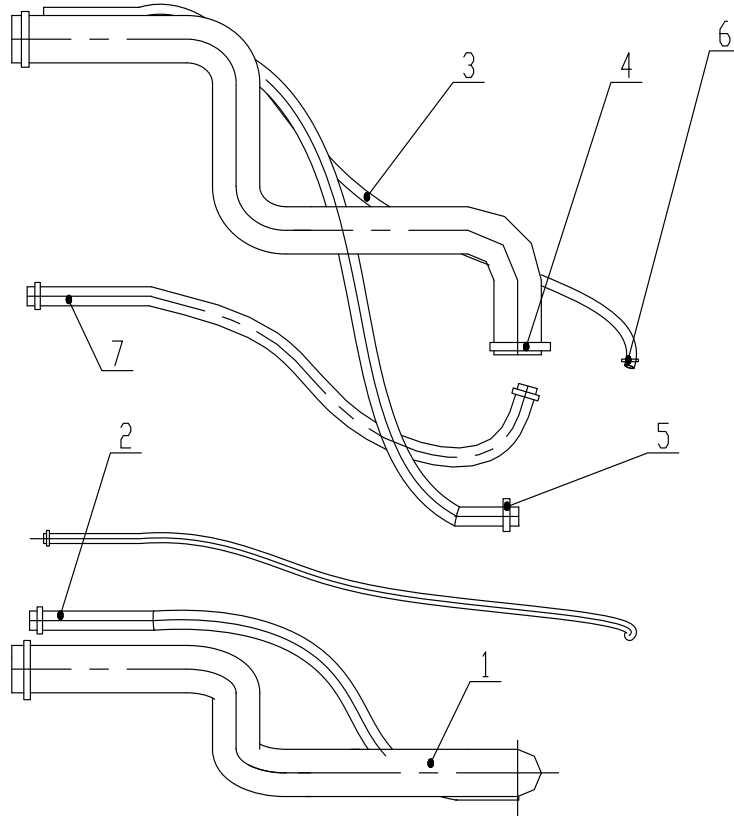

Z38G0106 出水胶管总成 Water Outlet Pipe Assembly

序号 Item	代号 Part No.	名 称 Parts Name	数量 Q'ty	备注 Remark
1	Z38G010600001	出水胶管 Inlet Water Pipe	1	
2	Z38G010600002	φ21补水管 Supply Water Pipe	3米	
3	Z38G010600003	φ10蒸汽管 Steam Pipe	2米	
4	φ50-φ60	卡箍 Clamp	2	
5	φ20-φ30	卡箍 Clamp	4	
6	φ10-φ20	卡箍 Clamp	2	
7	Z38G010600004	φ16小循环管 Small Circle Pipe	1	

变矩器变速箱  
**Torque Converter Transmission**



# Z38G03T2 变矩器变速箱 Torque Converter Transmission

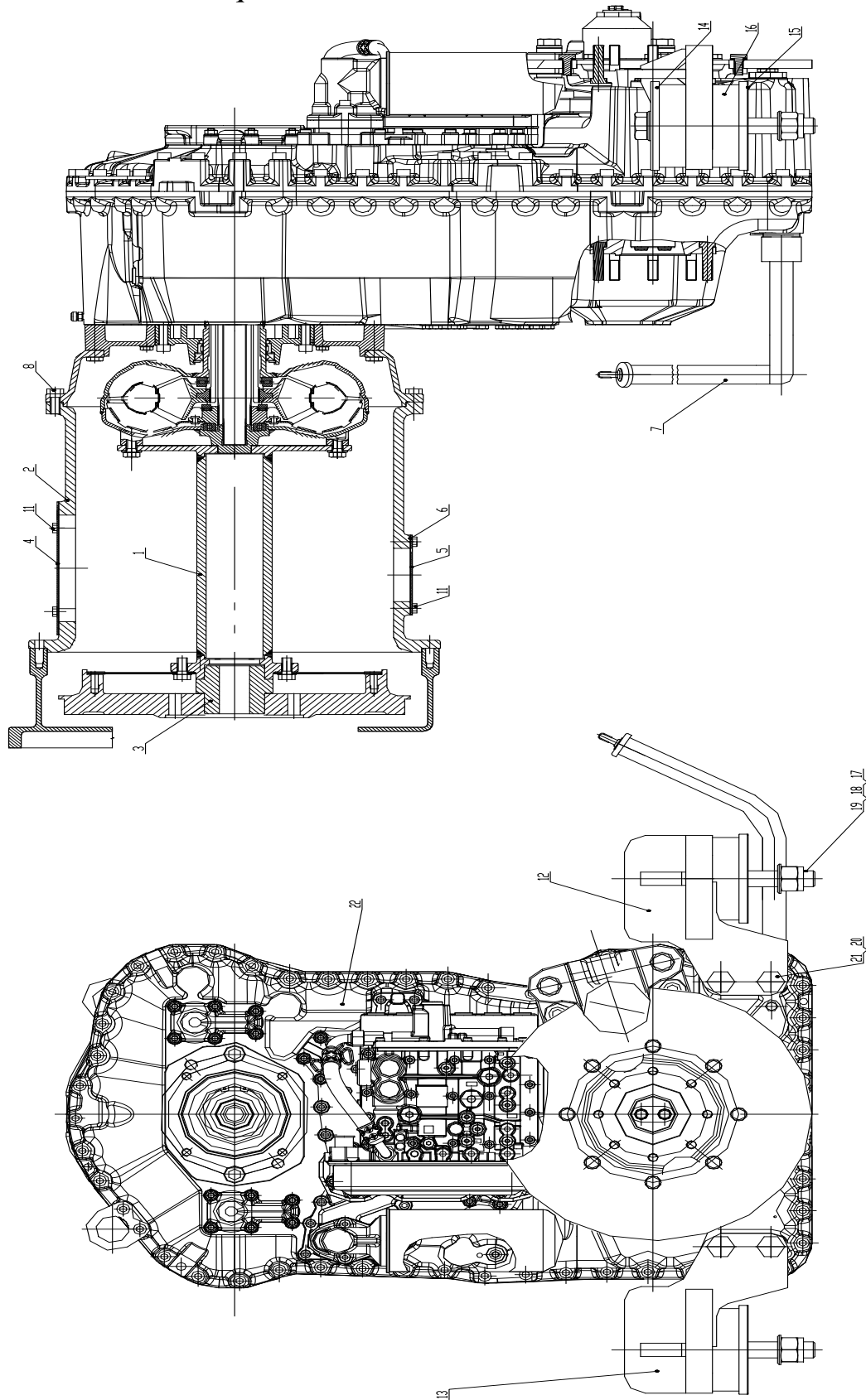

## Z38G03T2 变矩器变速箱 Torque Converter Transmission

序号 Item	代号 Part No.	名 称 Parts Name		数量 Q'ty	备注 Remark
1	Z38G0301T2	连接筒	Horn Driving Sleeve	1	
2	Z38G03000001T2	变矩器壳体	Pump Body	1	
3	Z38G03000002T2	过渡套	Interim Cover	1	
4	Z35G02000002T1	上盖板	Plate	1	
5	Z35G02000003T1	下盖板	Plate	1	
6	Z35G02000004T1	下盖板纸垫	Seal Gasket	1	
7	Z35G0309T1	加油管总成	Oil Pipe Assembly	1	
8	GB/T5783-2000	螺栓M10X30	Bolt M12X30	12	
9					
10					
11	GB/T5783-2000	螺栓M8X16	Bolt M8X16	8	
12	Z35G0303T3	变速箱左支架	Left Support	1	
13	Z35G0302T3	变速箱右支架	Right Support	1	
14	Z35G03000003T3	垫板 II	Washer II	4	
15	Z35G03000004T3	调整垫 II	Adjusting Shim II	2组	
16	CB-2205-1	减振垫	Pamper	2	外购LORD
17	GB/T97.2-2002	垫圈24	Washer 24	4	
18	GB/T889.1-2000	螺母M24	Bolt M24	2	
19	GB/T5783-2000	螺栓M24X200	Bolt M24X200	2	
20	GB/T97.2-2002	垫圈20	Washer 20	4	
21	GB/T5783-2000	螺栓M20X40	Bolt M20X40	4	
22	ZF 4WG-158	双变总成	Torque Converter Transmission	1	外购德国ZF

# 变速油路及操纵系统

## Transmission Oil Line and Control

**Z38G04T1 变速油路及操作系统**  
**Transmission Oil Line And Control System**

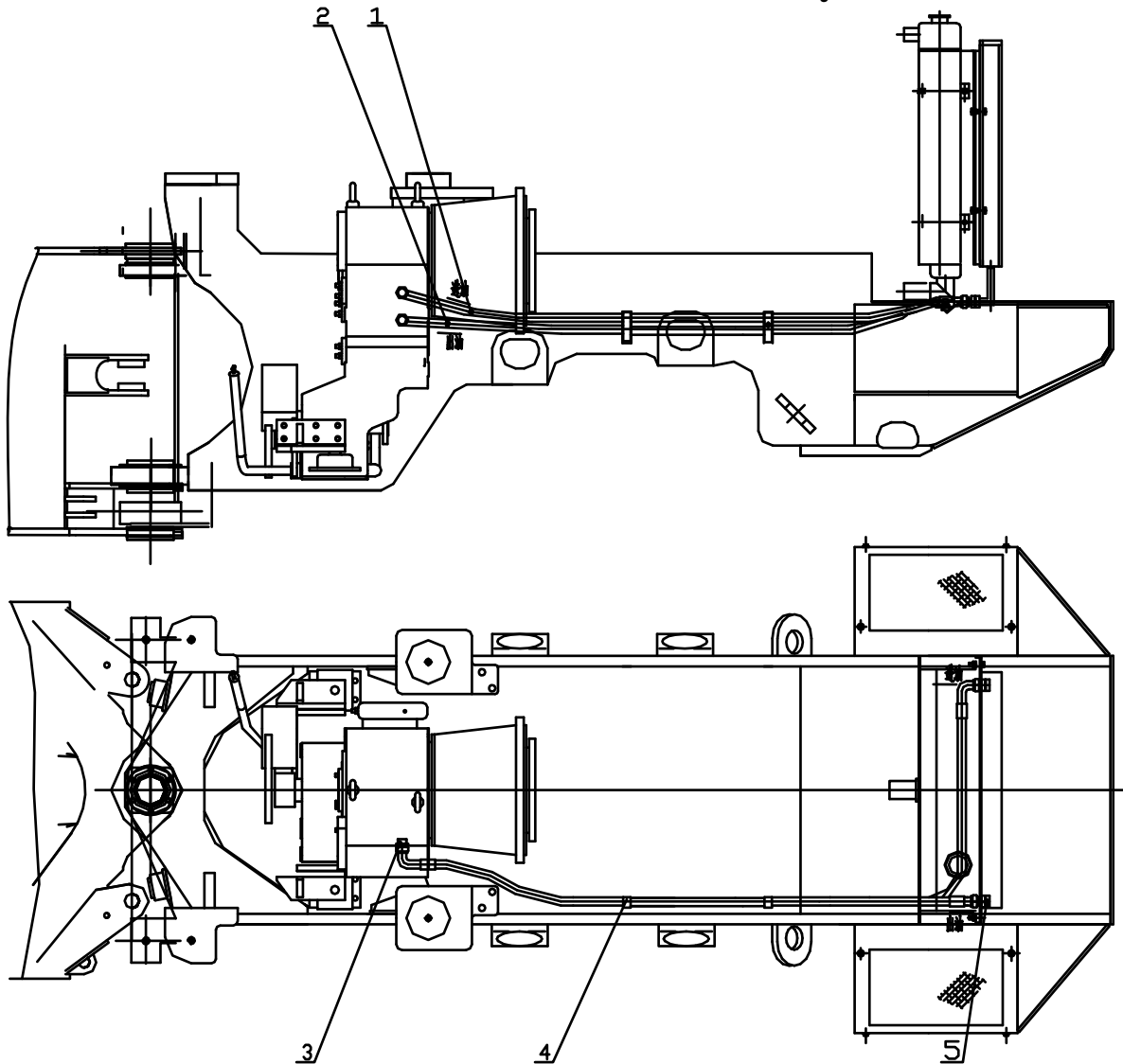

**Z38G04T1 变速油路及操作系统**  
**Transmission Oil Line And Control System**

序号 Item	代号 Part No.	名 称 Parts Name	数量 Q'ty	备注 Remark
1	20491-36-12TZ/20411-30-12 ZX1T12GTX2140	软管总成 Hose	1	
2	20491-30-12TZ/20491-36-12 ZX1T12GTX2560V180	软管总成 Hose	1	
3	1C0-36-16Z	接头 Connector	2	
4	TTPG1-430	管夹总成 Clamp	2	
5	1CH-30-27DZ	接头 Connector	2	

前桥、后桥  
**Front Axle & Rear Axle**

Z35G05T9 后桥 Rear Axle  
 Z35G06T9 前桥 Front Axle

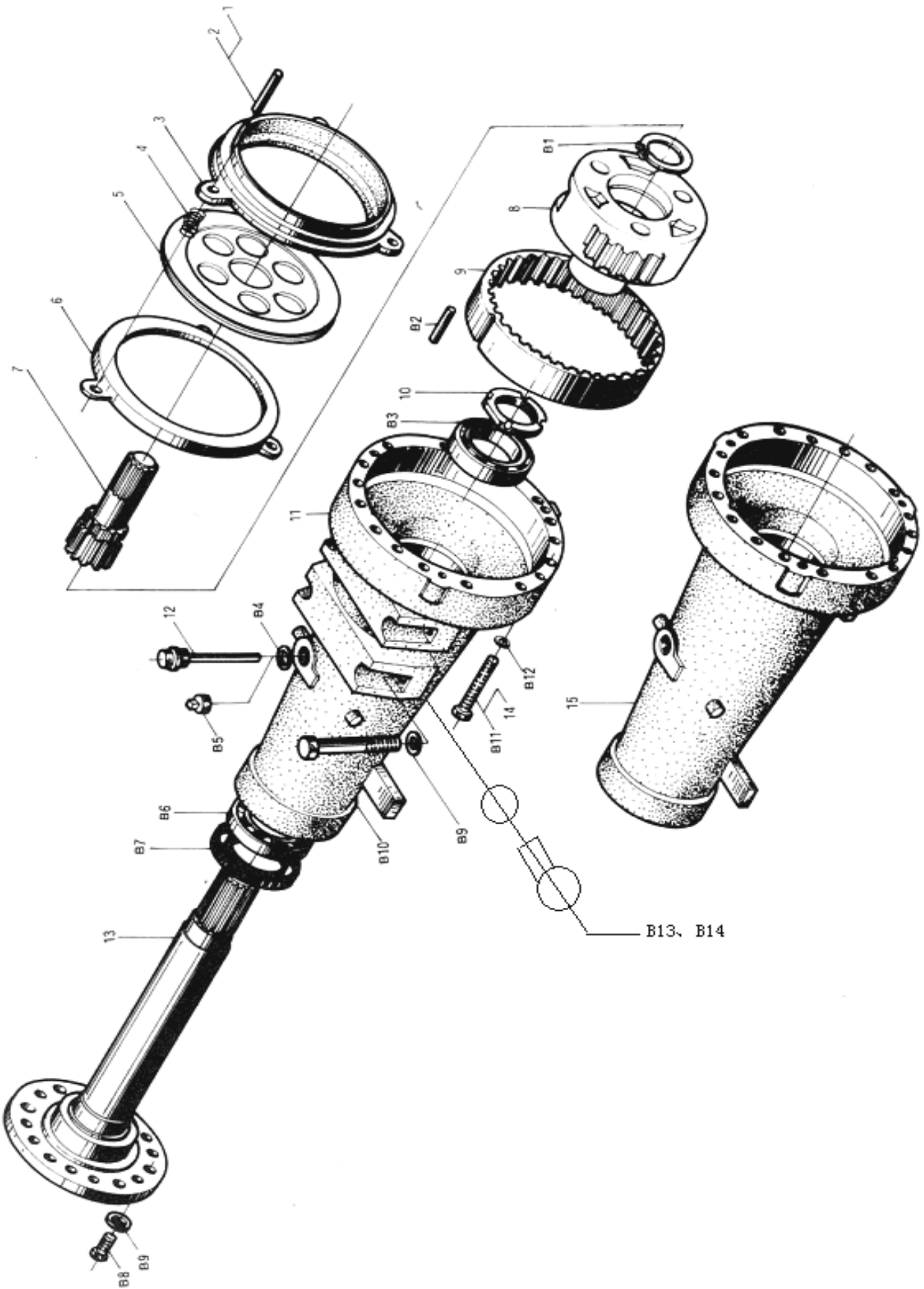

**Z35G05T9 后桥      Rear Axle**  
**Z35G06T9 前桥      Front Axle**

序号 Item	代号 Part No.	名 称 Parts Name	数量 Q'ty	备注 Remark
1	GB119-86	销A12X120	Pin A12X120	3
2	GB119-86	销A12X100	Pin A12X100	3
3	Z30060000006c	制动器活塞	Piston	2
4	06F5701	回位弹簧	Spring	6
5	Z35F0602	制动片	Brake Disc	2
6	Z30060000005c	支板	Axle	2
7	Z30060000007	太阳轮	Sun Gear	2
8	Z300602	轮边减速器	Hub Reducer	2
9	Z30060000004	内齿圈	Inner Gear Ring	2
10	Z30060000003	锁紧螺母	Nut	2
11	Z30060000002	桥壳	Axle Case	2
12	Z300605	呼吸螺塞总成	Connector	1
13	Z30060000001	半轴	Half Shaft	2
14	Z30060000009	桥壳长螺栓	Bolt	16
15	Z30050000001	桥壳	Axle Case	2
B1	GB894.1-86	挡圈75	Snap Ring 75	2
B2	GB120-86	销B12X35	Pin B12X35	6
B3	GB297-94	轴承32018	Bearing 32018	2
B4	Q/CG302.11-95	垫圈33	Washer 33	2
B5	Q/CG302.12-95	螺塞	Plug M33X2	1
B6	GB297-94	轴承32020	Bearing 32020	2

Z35G05T9 后桥 Rear Axle  
Z35G06T9 前桥 Front Axle

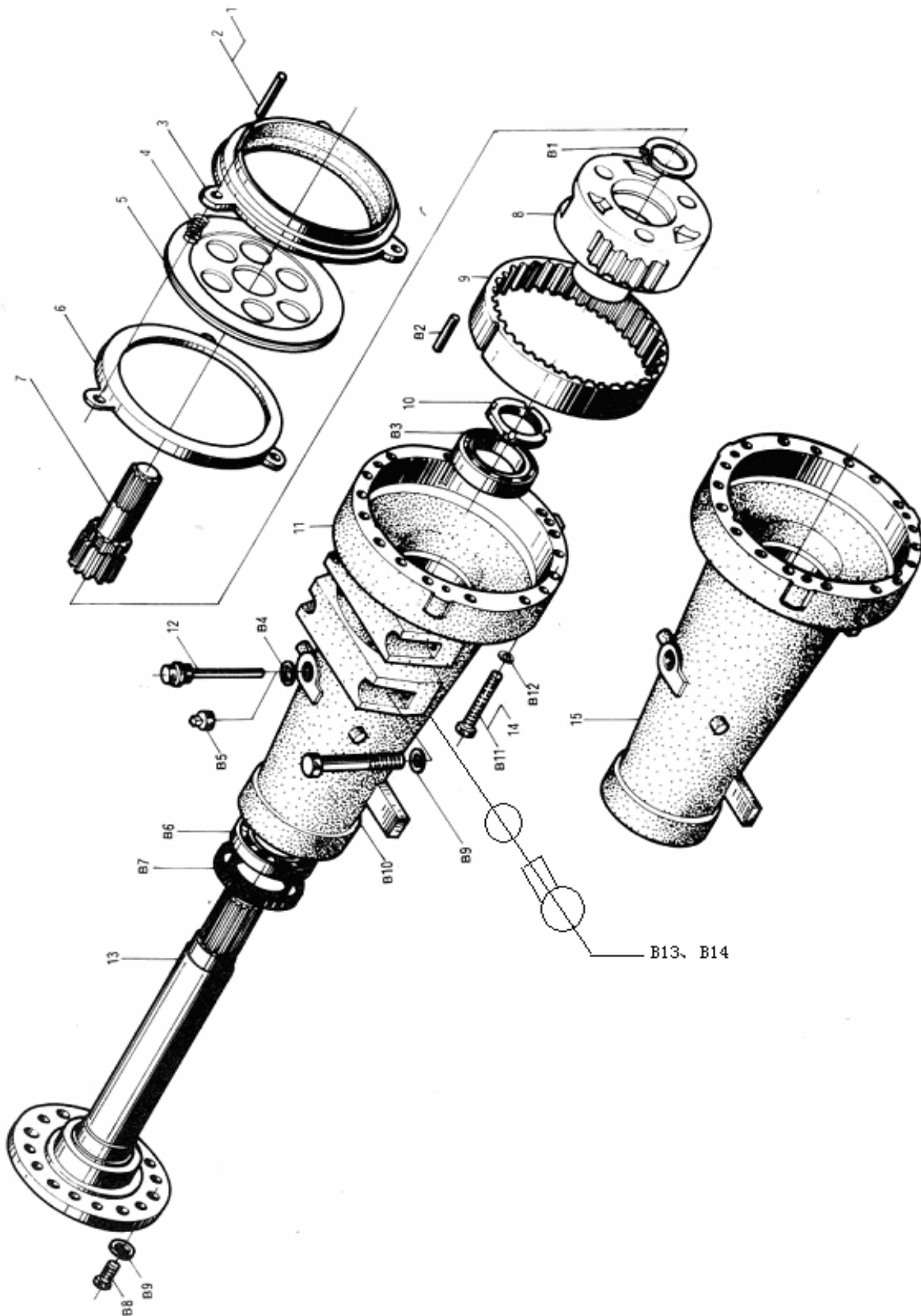



**Z35G05T9 后桥 Rear Axle**  
**Z35G06T9 前桥 Front Axle**

序号 Item	代号 Part No.	名 称 Parts Name		数量 Q'ty	备注 Remark
B7	GB13871-92	密封圈FB150180	Seal Ring FB150180	2	前桥40, 后桥32
B8	GB5786-86	螺栓M24X2X50	Bolt M24X2X50	32	
B9	GB97.2-85	垫圈24	Washer 24		
B10	GB5785-86	螺栓M24X2X180	Bolt M24X2X180	8	
B11	GB5785-86	螺 栓 M16X1.5X100	Bolt M16X1.5X100	16	
B12	GB97.2-85	垫圈16	Washer 16	32	
B13	JB982-77	垫圈14	Washer14	2	
B14	CG302.12-95	螺塞M14X1.5	Plug M14X1.5	2	

Z35G0501T9

齿箱 Differential

Z35G0601T9

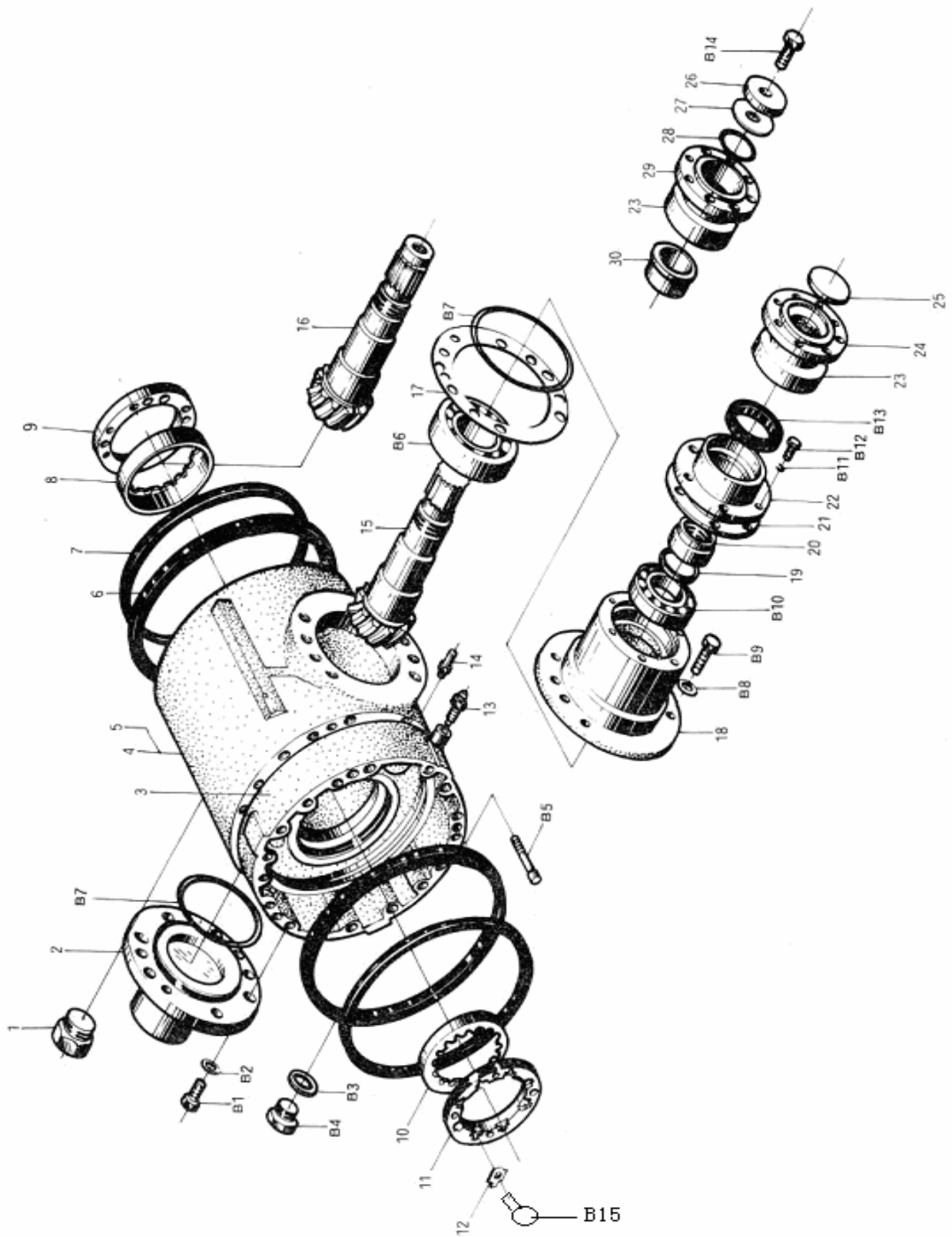

## Z35G0501T9

## 齿箱 Differential

## Z35G0601T9

序号 Item	代号 Part No.	名 称 Parts Name		数量 Q'ty	备注 Remark
1	CG50. 6. 5	磁铁油塞	Plug	1	
2	Z30050100001	后支承轴	Shaft	1	
3	Z30060100011c	制动器油缸	Cylinder	1	
4	Z30050100005c	齿箱壳体	Differential Body	1	
5	Z30060100001c	齿箱壳体	Differential Body	1	
6	Z30060000010	活塞密封圈 (II)	Seal Ring (II)	2	
7	Z30060000011	活塞密封圈 (I)	Seal Ring (I)	2	
8	Z30060100005	轴承外套 (大端)	Sleeve	1	
9	Z30060100009	调整螺母 (大端)	Nut	1	
10	Z30060100013	轴承外套 (小端)	Sleeve	1	
11	Z30060100014	调整螺母 (小端)	Nut	1	
12	Z30060100006	调整螺母锁紧垫圈	Nut	2	
13	Z30060100027	排气塞	Plug	2	
15	Z35G050100001T9	主动锥齿轮 (后桥)	Drive Bevel Gear	1	
16	Z35G060100001T9	主动锥齿轮 (前桥)	Drive Bevel Gear	1	
17	Z30060100016	主传动调节垫片	Gasket	1组	
18	Z35G060100003T9	中壳	Housing	1	
19	GB858-88	垫圈64	Gasket 64	1	
20	GB/T810-88	螺母M64X2	Nut M64X2	2	
21	Z30060100024	小盖纸垫	Gasket	1	
22	Z40F060100005	小盖	Cap	1	
23	CG50. 6. 1-21a	防尘罩	Dust Cowl	1	
24	Z40F050100002	连接凸缘 (后桥)	flange	1	

Z35G0501T9

齿箱 Differential

Z35G0601T9

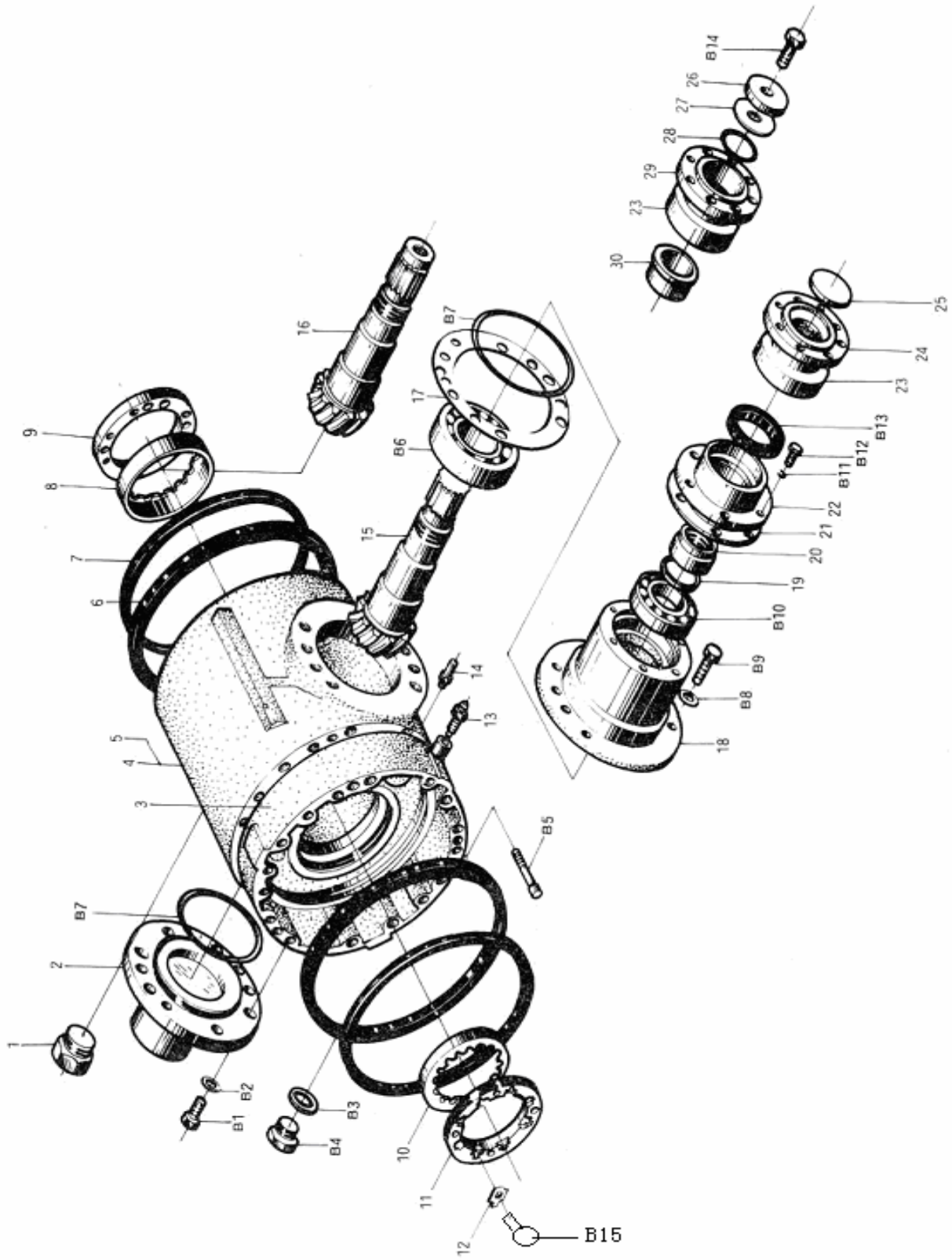

## Z35G0501T9

## 齿箱 Differential

## Z35G0601T9

序号 Item	代号 Part No.	名 称 Parts Name	数量 Q'ty	备注 Remark
25	CG50.6.1-23S	挡板	1	
26	06F1802	压板	1	
27	GB858-88	垫圈64	1	
28	06F3501	O型圈	1	
29	Z40F060100004	连接凸缘（前桥）	1	
30	GB/T810-88	螺母M64X2	1	
B1	GB5786-86	螺栓M16X1.5X40	8	
B2	GB97.2-85	垫圈16	8	
B3	Q/CG302.11-95	垫圈33	2	
B4	Q/CG302.12-95	螺塞M33X2	2	
B5	GB70-85	螺钉M12X80	3	
B6	GB297-94	轴承33215	1	
B7	GB3452.1-92	O形圈140X3.55		前桥 1, 后桥 2
B8	GB97.2-85	垫圈16	8	
B9	GB5786-86	螺栓M16X1.5X35	8	
B10	GB297-94	轴承33213	1	
B11	GB97.2-85	垫圈8	6	
B12	GB5786-86	螺栓M8X1X25	6	
B13	GB13871-92	密封圈075095	1	
B14	GB5782-86	螺栓M16X50	1	
B15	GB5783-86	螺栓M6X12	2	

Z35G0501T9  
齿箱 Differential  
Z35G0601T9

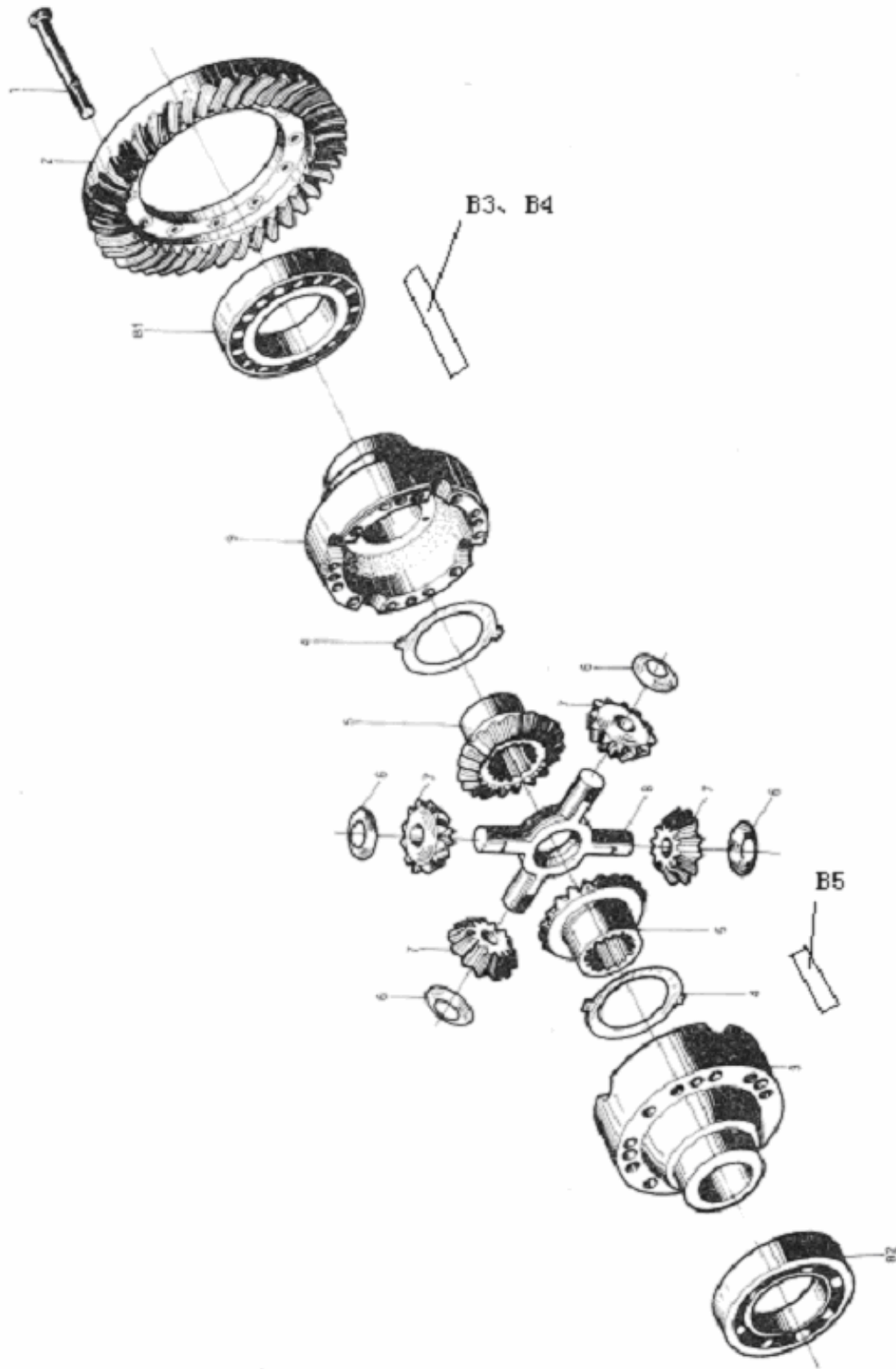

**Z35G0501T9****齿箱 Differential****Z35G0601T9**

序号 Item	代号 Part No.	名 称 Parts Name	数量 Q'ty	备注 Remark
1	Z30060100025	半壳螺栓	Bolt	12
2	Z35G060100002T9	从动锥齿轮	Driven Bevel Gear	1
3	Z30060100012	差速器半壳I	Differential Case I	1
4	CG50.6.1-9	大锥齿轮垫片	Pinion Gasket	2
5	CG50.6.1-12	大锥齿轮	Bevel Gear	2
6	CG50.6.1-14	小锥齿轮垫	Pinion Gasket	4
7	CG50.6.1-13	小锥齿轮	Pinion	4
8	Z30060100028	十字轴	Cross Shaft	1
9	Z30060100008	差速器半壳 (II)	Differential Case II	1
B1	GB297-94	轴承32019	Bearing 32019	1
B2	GB297-94	轴承32017	Bearing 32017	1
B3	GB879-86	销B12X50	Pin 12X50	4
B4	GB879-86	销8X50	Pin 8X50	4
B5	GB119-86	销A6X18	Pin A6X18	2

# Z300602 轮边减速器 Hub Reducer

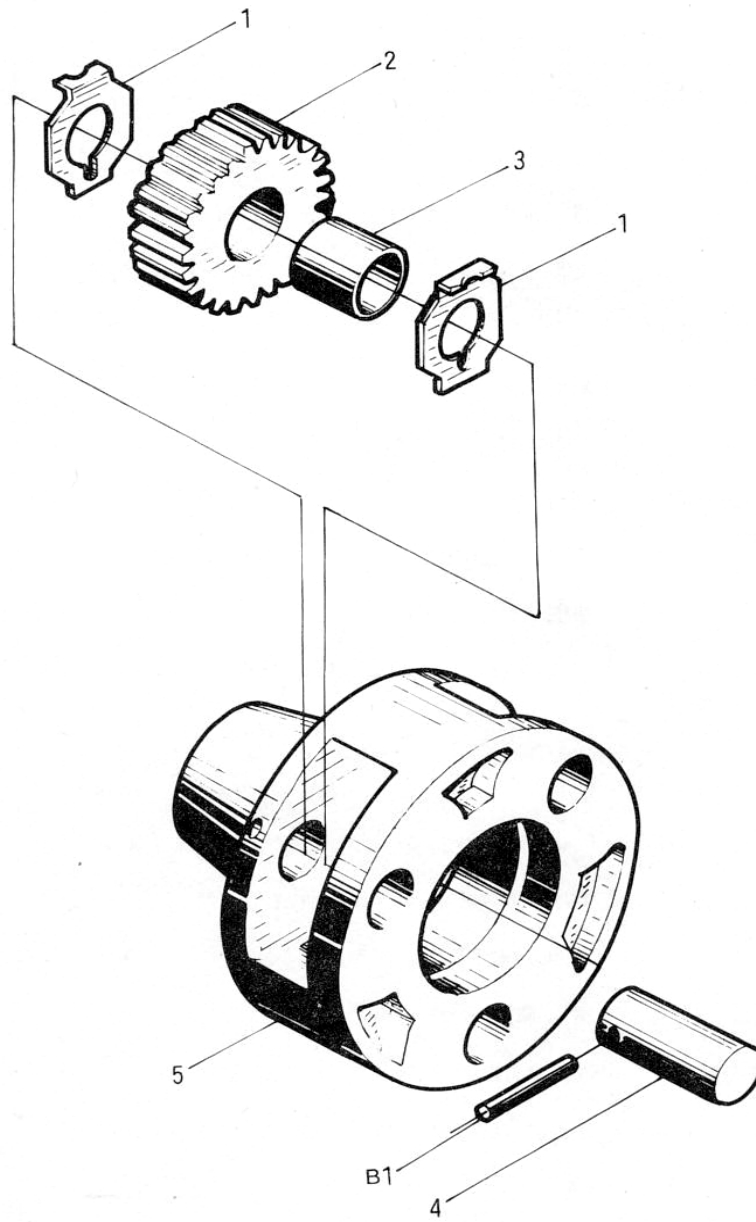



## Z300602 轮边减速器 Hub Reducer

序号 Item	代号 Part No.	名 称 Parts Name		数量 Q'ty	备注 Remark
1	Z30060200004	防转垫圈	Washer	6	
2	Z30060200002	行星齿轮	Gear	3	
3	Z30060200005	轴套	Sleeve	3	
4	Z30060200003	行星轮轴	Planet Shaft	3	
5	Z30060200001	行星架	Planet Carrier	1	
B1	GB879-86	销8X35	Pin 8X35	3	
B2	GB879-86	销5X35	Pin 5X35	3	

# 轮胎总成 Rim Assembly

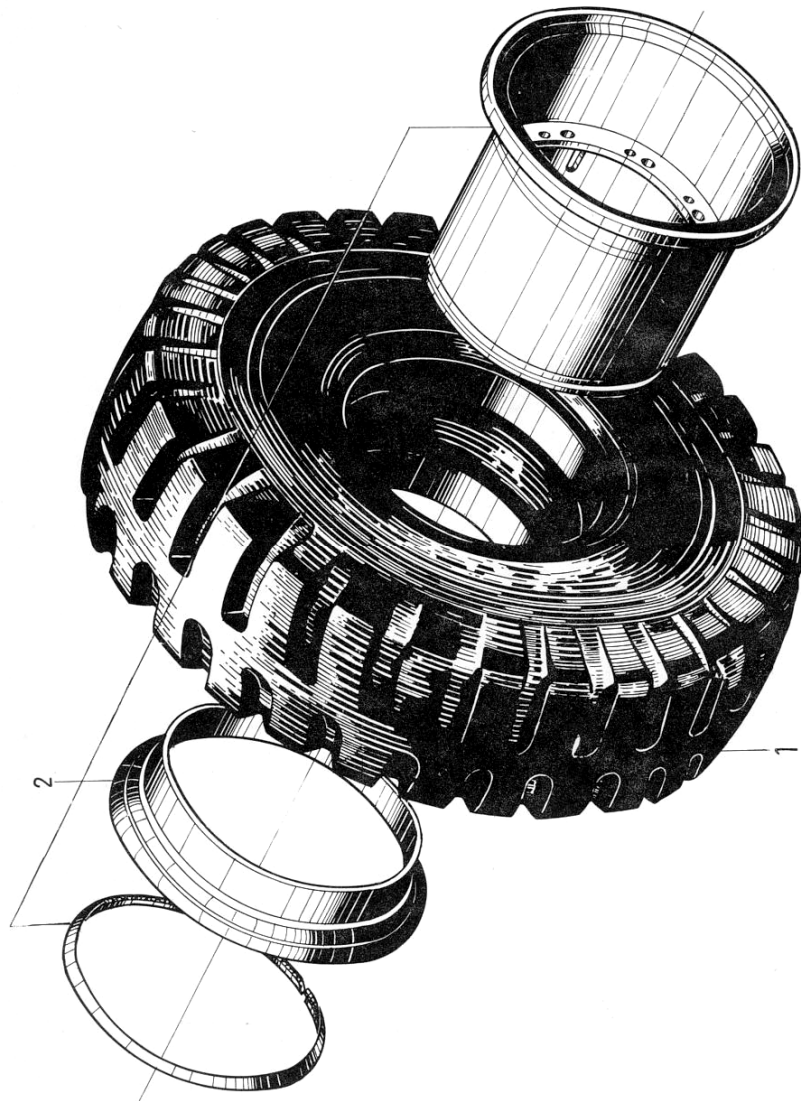

## 轮胎总成 Rim Assembly

序号 Item	代号 Part No.	名 称 Parts Name		数量 Q'ty	备注 Remark
1		轮胎20.5-25-20PR(TL)	Tire 20.5-25-20PR(TL)	4	
2	Z35G0602T9	轮辋总成	Rim	4	外购CQ30B-01A

**Z300502 前支承架总成 Front Support Carrier**  
**Z300503 后支承架总成 Rear Support Carrier**

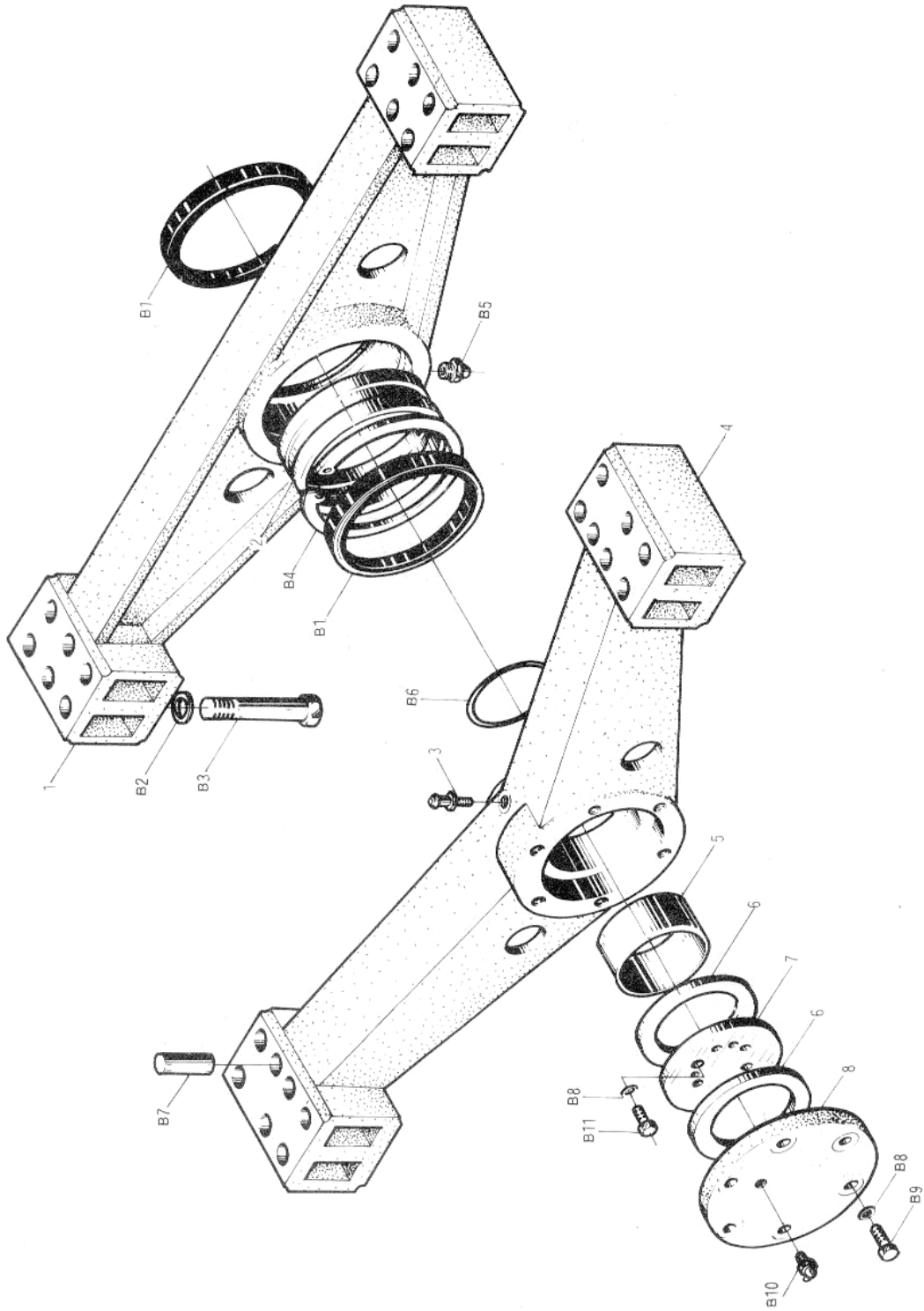

**Z300502 前支承架总成 Front Support Carrier**  
**Z300503 后支承架总成 Rear Support Carrier**

序号 Item	代号 Part No.	名 称 Parts Name	数量 Q'ty	备注 Remark
1	Z30050200001	支承架	Support Carrier (Front)	1
2	Z30050200002	衬套	Bushing	1
3	ZL30b.6.6	排气嘴	Exhaust Hole	1
4	Z30050300001	支承架	Support Carrier (Rear)	1
5	Z30050300003	衬套	Bushing	1
6	Z30050300004	耐磨板	Plate	2
7	Z30050300005	转盘	Disc	1
8	Z30050300002	端盖	Cover	1
B1	GB13871-92	油封FB160X190	Seal Ring FB160X190	2
B2	GB97.2-85	垫圈16	Washer 16	24
B3	GB5785-86	螺栓M16X1.5X140	Bolt M16X1.5X140	24
B4	GB893.1-86	挡圈190	Snap Ring 190	2
B5	GB1152-89	油杯M10X1	Oil Cup M10X1	1
B6	GB3452.1-92	O形圈100X5.3	O-Ring 100X5.3	1
B7	GB119-86	销A20X70	Pin A20X70	2
B8	GB97.2-85	垫圈12	Washer 12	12
B9	GB5786-86	螺栓M12X1.5X40	Bolt M12X1.5X40	6
B10	GB1152-89	油杯M10X1	Oil Cup M10X1	1
B11	GB/T32.1-1988	螺栓M12X1.5X30	Bolt M12X1.5X30	6
B12	GB343-94	锁紧钢丝	Steel wire	3

前传动轴  
**Front Driving Shaft**

# Z38G07 前传动轴 Front Drive Shaft

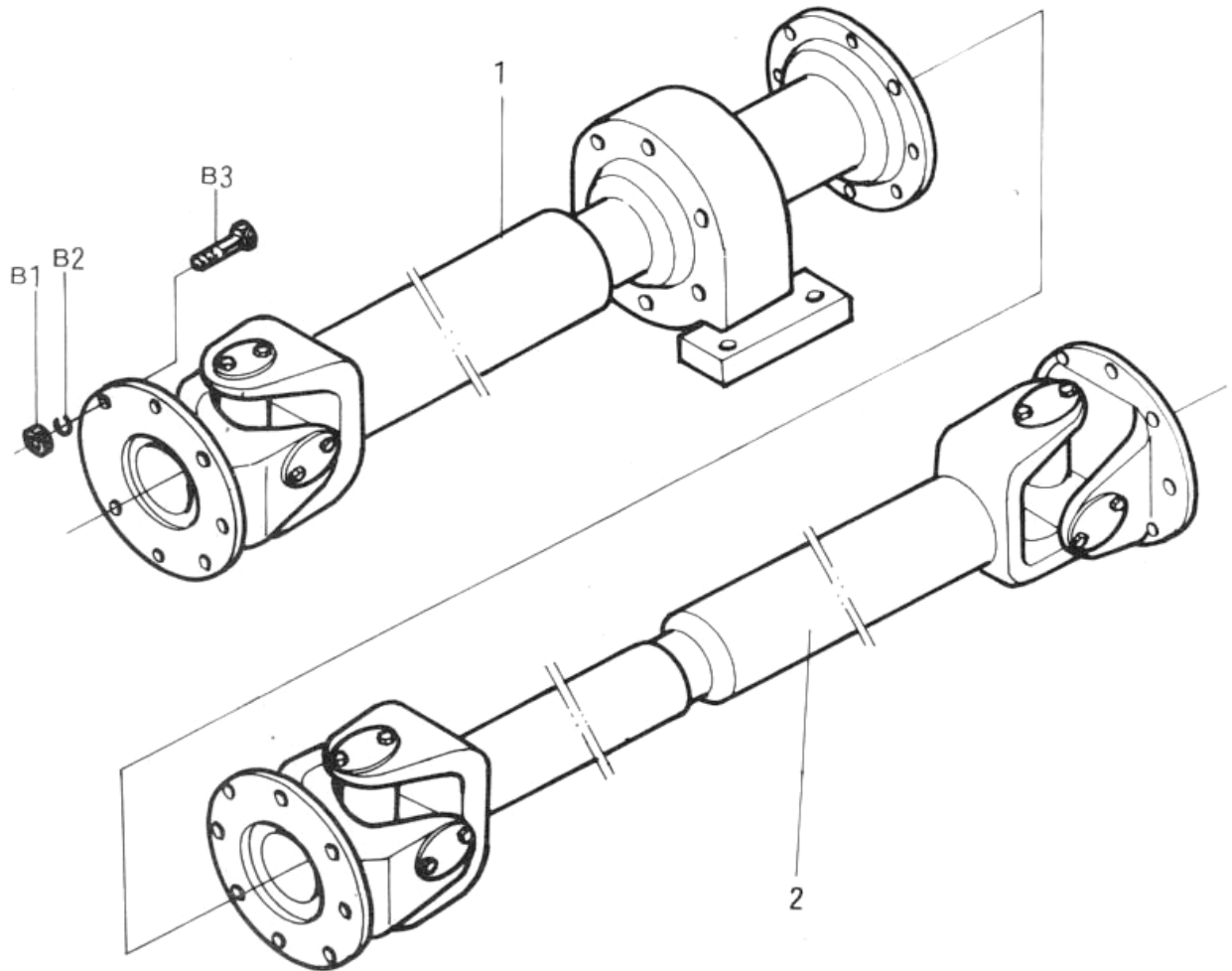

## Z38G07 前传动轴 Front Drive Shaft

序号 Item	代号 Part No.	名 称 Parts Name		数量 Q'ty	备注 Remark
1	Z38G0701	前传动轴	Shaft and Support	1	
2	Z38G0702	中传动轴	Shaft	1	
B1	GB889.1-2000	螺母M12	Nut M12	24	
B3	GB5783-2000	螺栓M12X40	Bolt M12X40	16	
	GB5783-2000	螺栓M14X45	Bolt M14X45	4	
	GB93-87	垫圈14	Washer 14	4	
	GB97.1-2000	垫圈14	Washer 14	4	



# 转向系统

## **Steering System**

# Z38G08T1 转向系统 Steering System

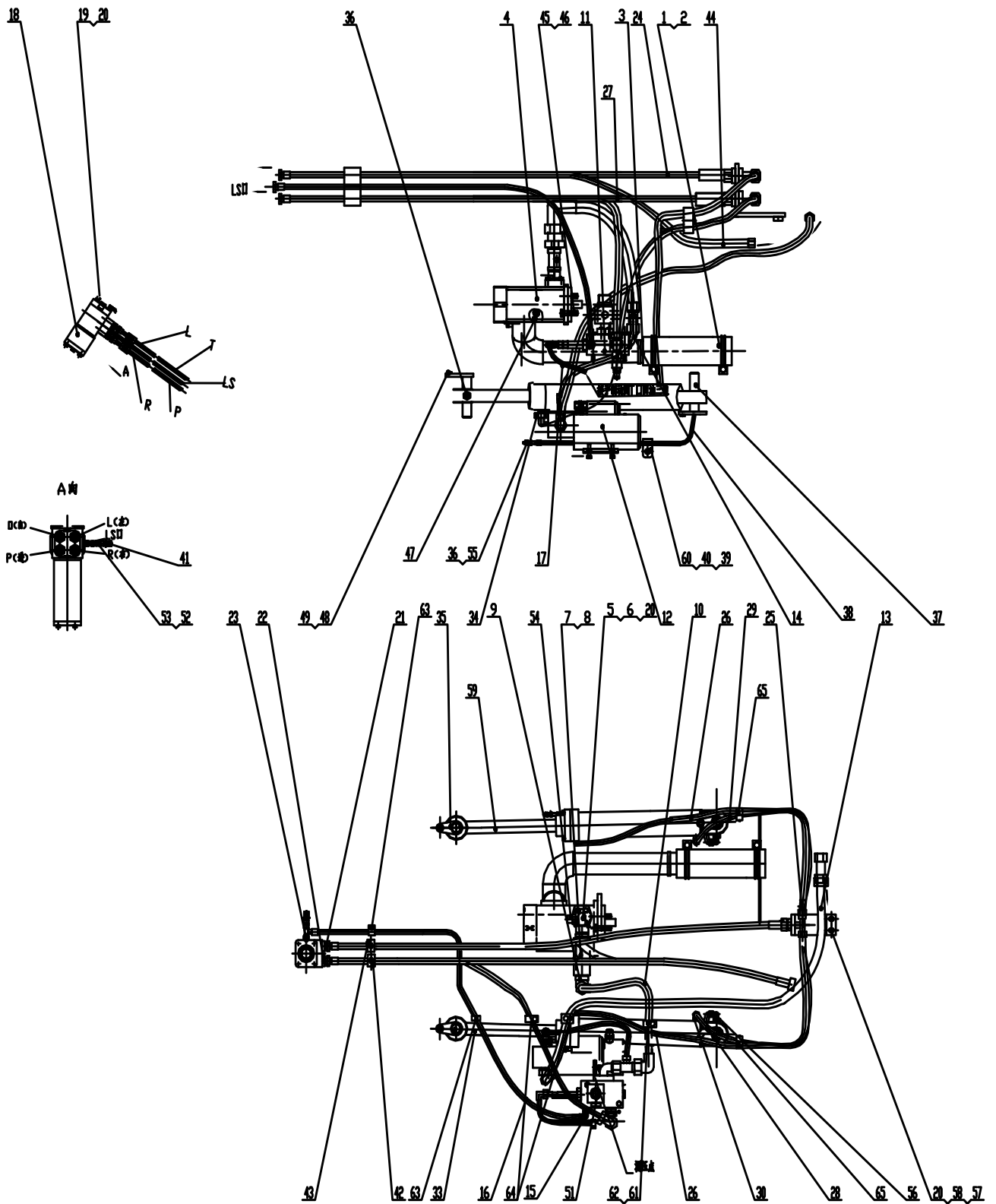

## Z38G08T1 转向系统 Steering System

序号 Item	代号 Part No.	名 称 Parts Name	数量 Q'ty	备注 Remark	
1	Φ 84X400	耐油胶管	Hose Φ 84X400	1	
2	Φ 85- Φ 100	卡箍	Clamp Φ 85- Φ 100	4	
3	Z38G0801T1	吸油管总成	Suction Pipe	1	
4	3520VQ21A12-297DD20(右旋)	双联叶片泵	vane pump	1	
5	FL-20(配螺栓: SAE7/16-14UNC-2A)Z	法兰组件	Connector	1	
6	1DFL4-36-20Z	法兰接头	Connector	1	
7	2HD9-42-36OGZ	接头	Connector	1	
8	S25A02.0B	单向阀	Valve	1	
9	1DH9-36-42OGZ	接头	Connector	1	
10	20512-36-16Z/20592-36-16ZX4SP16X780	软管总成	Hose	1	
11	Z38G0804T1	优先转向阀总成	Valve	1	
12	Z50G0804T15	应急转向动力总成	Lash-up Clamp	1	
13	20411-36-12TZ/20411-30-12ZX1T12GT X1800	软管总成	Hose	1	
14	20491-22-08ZX2T08GTX285V90	软管总成	Hose	1	
15	20411-30-12ZX2T12GTX1980	软管总成	Hose	1	
16	20411-14-04ZX1T04GTX1900	软管总成	Hose	1	
17	20491-14-05Z/20491-18-05ZX1T05GT X380V0	软管总成	Hose	1	
18	BZZ-800(FK-0/20) (渐花、动态)	转向器	Steering Unit	1	
19	GB/T 5783-2000	螺栓M10×45	Bolt M10X45	4	
20	GB/T 93-1987	垫圈10	Washer10	10	
21	1CM-26-20WDZ	端直通接头	Connector	2	
22	1CM-30-20WDZ	端直通接头	Connector	2	
23	1CM-14-12WDZ	端直通接头	Connector	1	
24	20411-26-10ZX2T10ITX1420	软管总成	Hose	1	
25	AC6CC-26LN(带并紧螺母)	隔壁三通接头	Connector	2	
26	20441-26-08TZ/20411-26-08TZX2T08I TX1300	软管总成	Hose	2	
27	20411-26-10ZX2T10ITX1400	软管总成	Hose	1	
28	20411-26-08TZ/20441-26-08TZX2T08I TX780	软管总成	Hose	1	
29	20411-26-08TZ/20441-26-08TZX2T08I TX860	软管总成	Hose	1	
30	1CM-26-22WDZ	接头	Connector	2	
33	CG935GS-ZX1	左转向缸	Steering Cylinder	1	
34	1CH9-26-22OGZ	接头	Connector	2	
35	Z35H0802T16	前油缸销总成	Pin Assem.	2	
36	JB/T7940.1-1995	油杯M10X1	Oil Cup M10X1	4	
37	Z35H0801T16	后油缸销总成	Pin Assem.	2	
38	Z38G0806T1	转向轴润滑油管总成	Pipe	2	
39	K0608-10Z	管夹	Clamp	4	

## Z38G08T1 转向系统 Steering System

序号 Item	代号 Part No.	名 称 Parts Name	数量 Q'ty	备注 Remark	
40	GB/T 5783-2000	螺栓M10×15	Bolt M10X15	4	
41	PT-3-DKL	测压接头	Connector	1	
42	TTPG1-430	管夹总成	Clamp	1	
43	TTPG1-426.9	管夹总成	Clamp	1	
44	20411-30-12Z/20491-30-12ZX1T12ITX 1640	软管总成	Hose	1	
45	GB/T 5783-2000	螺栓M16X45	Bolt M16X45	2	
46	GB/T 93-1987	垫圈16	Washer16	6	
47	SAE5/8-11UNC-2A长50	螺栓	BoltSAE5/8-11UN C-2A	4	
48	GB/T 5783-2000	螺栓M12X30	Bolt M12X30	4	
49	GB/T 93-1987	垫圈12	Washer12	4	
51	Z38G0805T1	汇流座总成	Confluence Body Valve	1	
52	CC-14Z	三通接头	Connector	1	
53	7MC-14SZ	测压接头	Connector	1	
54	1CM-16-14WDZ	接头	Connector	1	
55	5QM9-12C-10FALNZ	接头	Connector	2	
56	2C9-26Z	接头	Connector	2	
57	Z38G080000001T1	支板	Supporting plate	1	
58	GB/T 5783-2000	螺栓M10X20	Bolt M10X20	2	
59	CG935GS-ZX2	右转向缸	Steering Cylinder	1	
60	GB/T 93-1987	垫圈8	Washer8	8	
61	K0608-40Z	管夹	Clamp	1	
62	GB/T 5783-2000	螺栓M8X20	Bolt M8X20	5	
63	K0608-16Z	管夹	Clamp	2	
64	K0608-29Z	管夹	Clamp	2	
65	TTPG1-322	管夹	Clamp	2	

# BZZ-800(FK-0/20) (渐花、动态) 转向器 Steering Unit

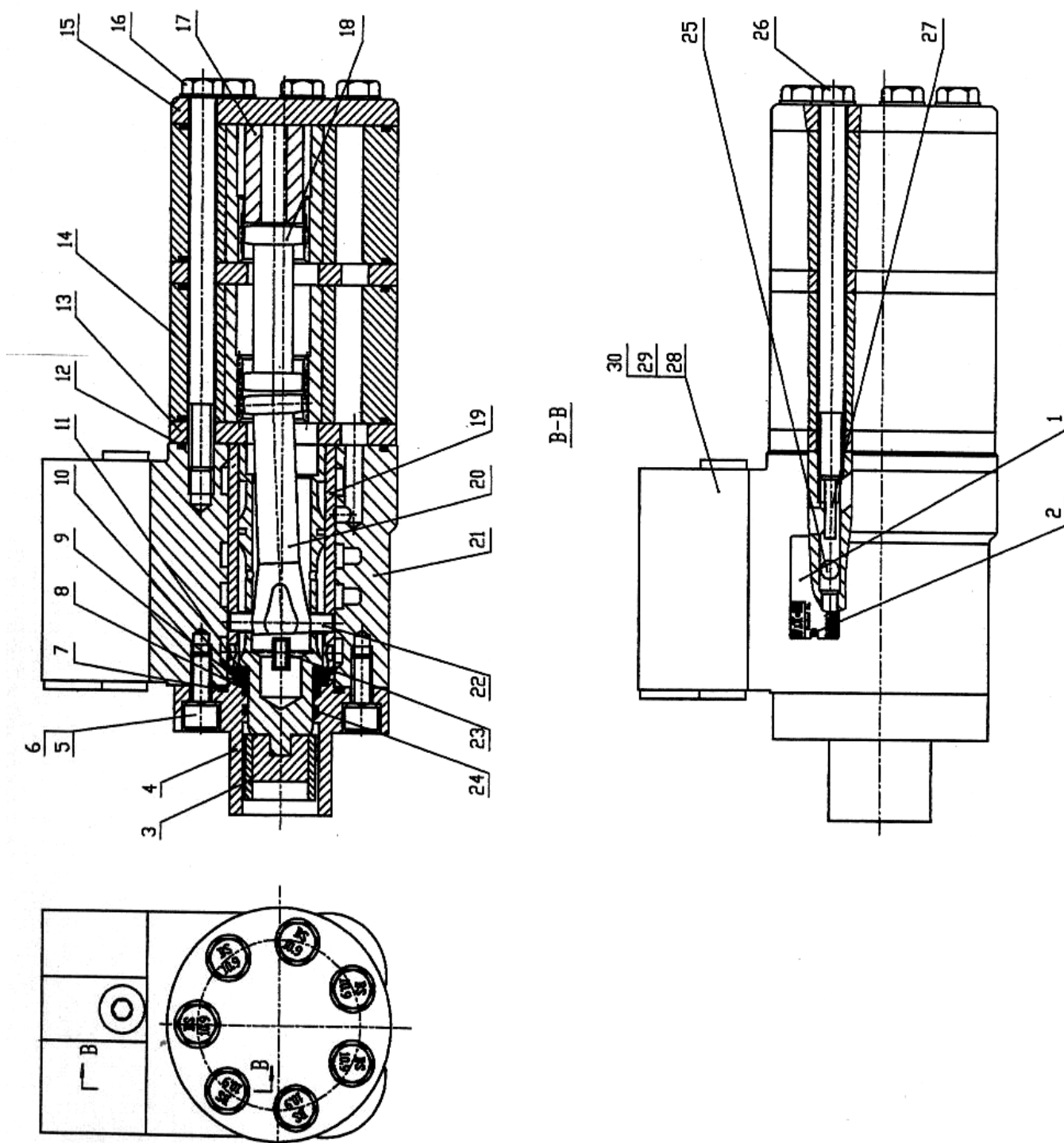

## BZZ-800(FK-0/20) (渐花、动态) 转向器 Steering Unit

序号 Item	代 号 Part No.	名 称 Parts Name	数量 Q'ty	备注 Remark	
1		标牌	Nameplate	1	
2		铆钉	Rivet	2	
3		连接块组件	Block Assembly	1	
4		前盖	Front Cover	1	
5		螺钉	Screw	4	
6		弹簧垫圈	Washer	4	
7		O形密封圈	O-Ring	1	
8		轴密封圈	Seal	1	
9		挡环	Ring	1	
10		滚针轴承	Ball Bearing	1	
11		滑环	Ring	1	
12		O形密封圈	O-Ring	5	
13		隔盘	Wear Plate	2	
14		定转子副	Gerotor Ring and star	2	
15		后盖	Rear Cover	1	
16		螺栓	Bolt	6	
17		限位块	Spacer	1	
18		联动轴I	Drive I	1	
19		阀芯阀套副	Spool and Cover	1	
20		联动轴II	DriveII	1	
21		阀体	Valve Body	1	
22		销子	Pin	1	
23		弹簧片	Reed	6	
24		O形密封圈	O-Ring	1	
25		钢球	Steel Sphere	1	
26		限位弹簧	Spring	1	
27		弹性圆柱销	Pin	1	
28		阀块	Valve	1	
29		螺钉	Screw	2	
30		O形密封圈	O-Ring	4	

## Z38G0801T1 吸油管总成 Suction Pipe

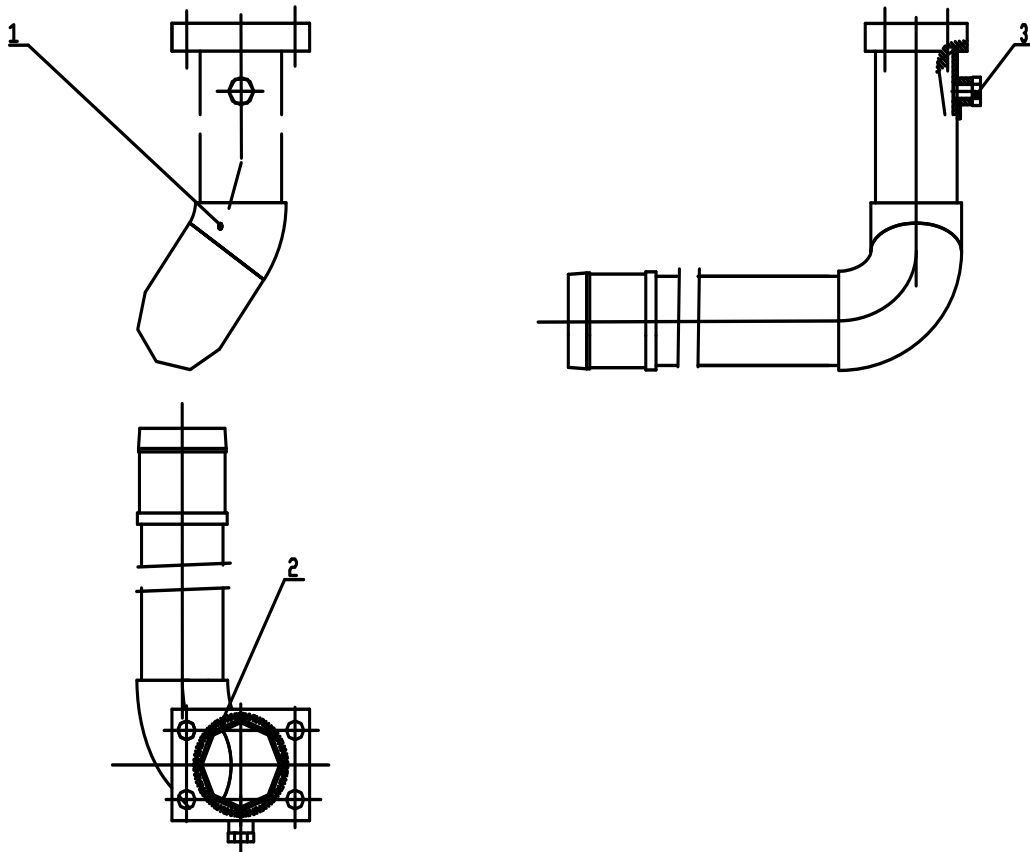

## Z38G0801T1 吸油管总成 Suction Pipe

序号 Item	代号 Part No.	名 称 Parts Name		数量 Q'ty	备注 Remark
1	Z38G080101T1	吸油管	Suction Pipe	1	
2	GB3452.1-92	O形圈82.5X3.55	O-Ring 82.5X3.55	1	
3	4M-14WD	堵头	plug up	1	

Z38G0804T1 优先转控阀总成 Valve

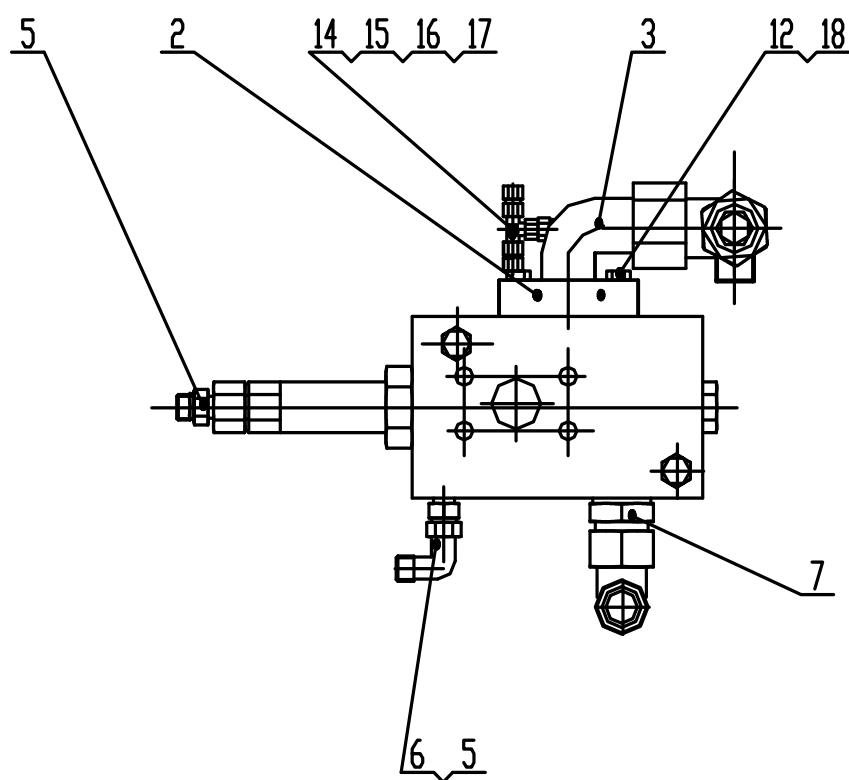
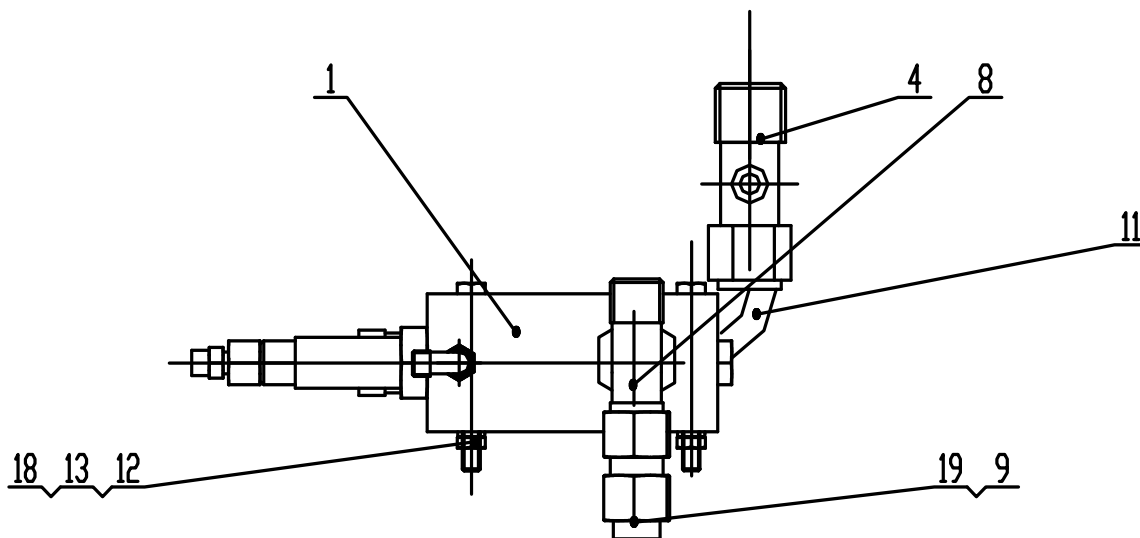



## Z38G0804T1 优先转控阀总成 Valve

序号 Item	代 号 Part No.	名 称 Parts Name	数量 Q'ty	备注 Remark	
1	VLE-150/882-6902-065	优先转控阀	Valve	1	
2	FL-20Z	法兰组件	Flange	1	
3	1DFL9-36-20M12(CG)Z	法兰接头	Connector	1	
4	CDCD-36-22-36Z	三通接头	Connector	1	
5	1CM-14-12WDZ	端直通接头	Connector	2	
6	2C9-14Z	90° 弯头	Connector	2	
7	1CM-30-33WDZ	端直通接头	Connector	1	
8	BC-30Z	三通接头	Connector	1	
9	7MC-14-30SZ	过渡接头	Connector	1	
10	2D9-36Z	90° 弯头	Connector	2	
11	GB/T70.1-2000	螺栓M10X100	Bolt M10X100	2	
12	GB/T 93-1987	垫圈10	Washer 10	6	
13	1CM-12WDZ	端直通接头	Connector	1	
14	BC-12Z	三通接头	Connector	1	
15	7MC-12SZ	过渡接头	Connector	2	
16	4M-12WDZ	堵头	Plug	1	
17	GB/T 6170-2000	螺母M10	Nut M10	2	
18	GB/T 5783-2000	螺栓M10X30	Bolt M10X30	4	
19	PT-3-DKL	测压接头	Connector	1	

Z50G0804T15 应急转向动力总成 Lash-up Clamp

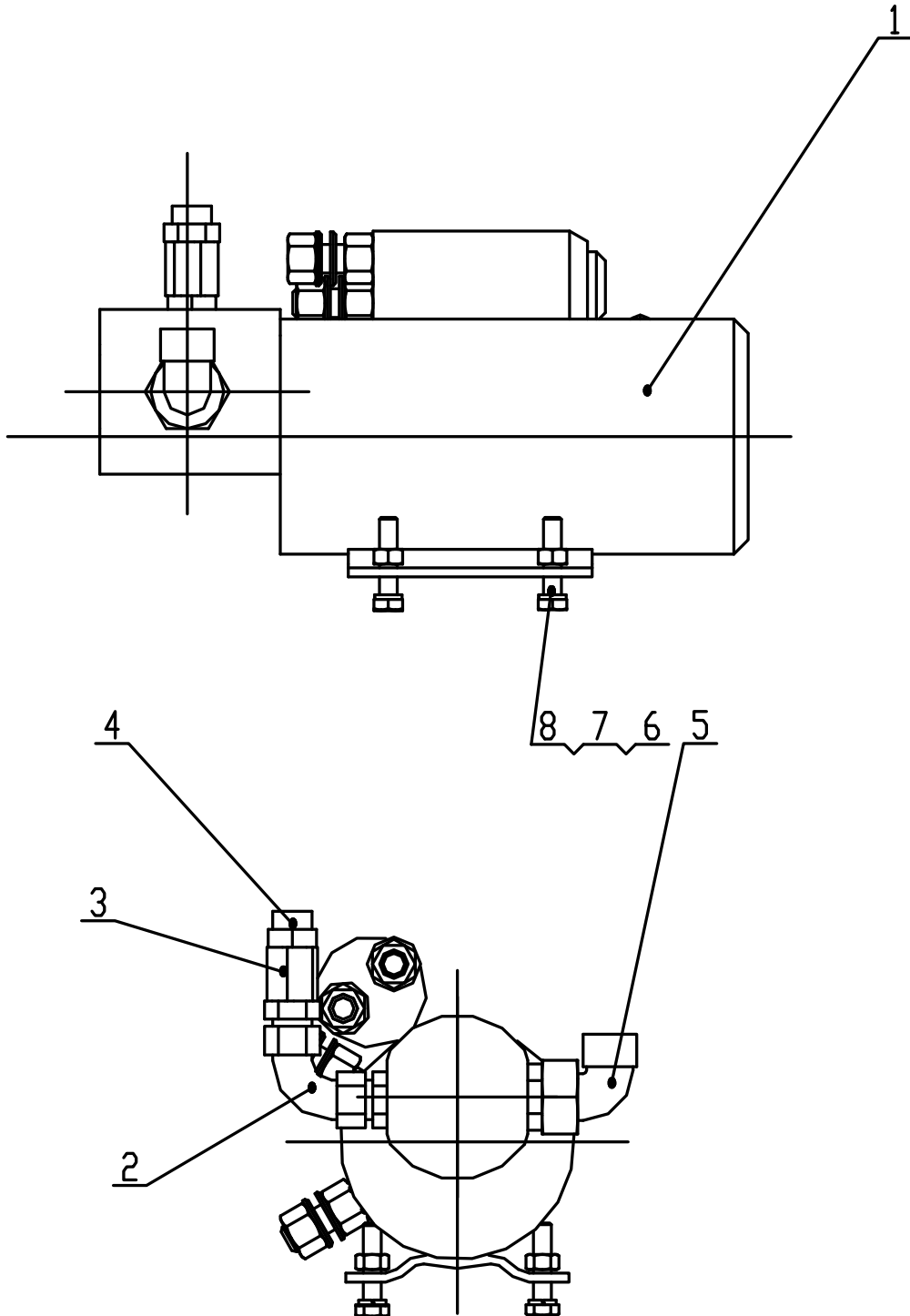

## Z50G0804T15 应急转向动力总成 Lash-up Clamp

序号 Item	代号 Part No.	名 称 Parts Name		数量 Q'ty	备注 Remark
1	12869-00	应急转向动力单元	Lash-up Clamp	1	
2	2HC9-22-18OG	弯接头	Connector	1	
3	RD-12L	单向阀	Valve	1	
4	2C-22-18	接头	Connector	1	
5	1CM-30-27WD (M27X2)	接头	Connector	1	
6	GB93-87	垫圈10	Washer 10	4	
7	GB/T70.1-2000	螺栓M10×45	Bolt M10X45	4	
8	GB41-86	螺母M10	Nut M10	4	

# 12869-00 应急转向动力单元 Lash-up Clamp

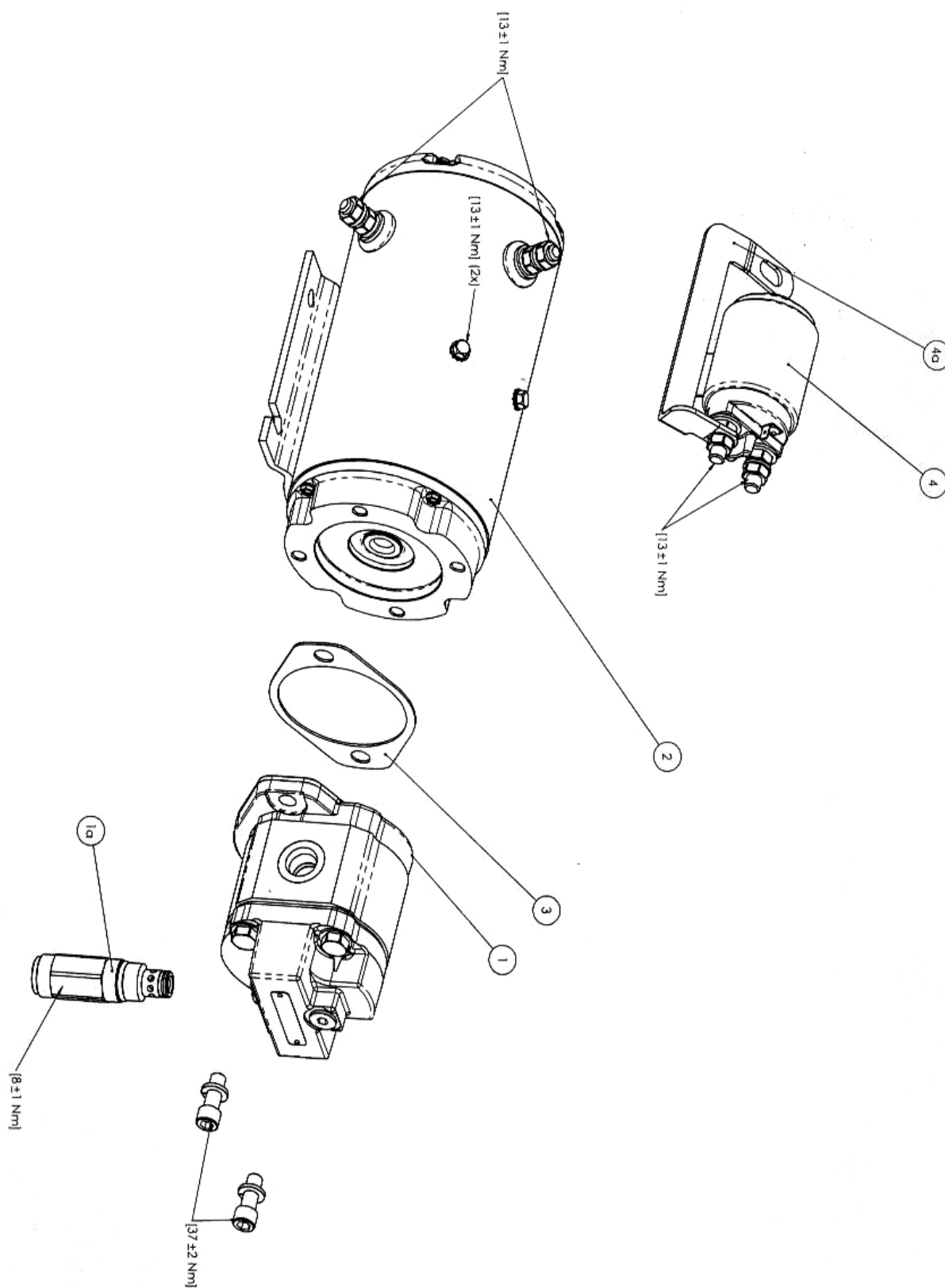

## 12869-00 应急转向动力单元 Lash-up Clamp

序号 Item	代号 Part No.	名 称 Parts Name	数量 Q'ty	备注 Remark	
1		泵总成	Pump Assembly	1	
1a		溢流阀	Pressure relief valve	1	
2		马达	Motor	1	
3		纸垫	Gasket	1	
4		起动开关	Start Switch Kit	1	
4a		母线	Bus Bar	1	

## Z38G0805T1 汇流座总成 Confluence Body Valve

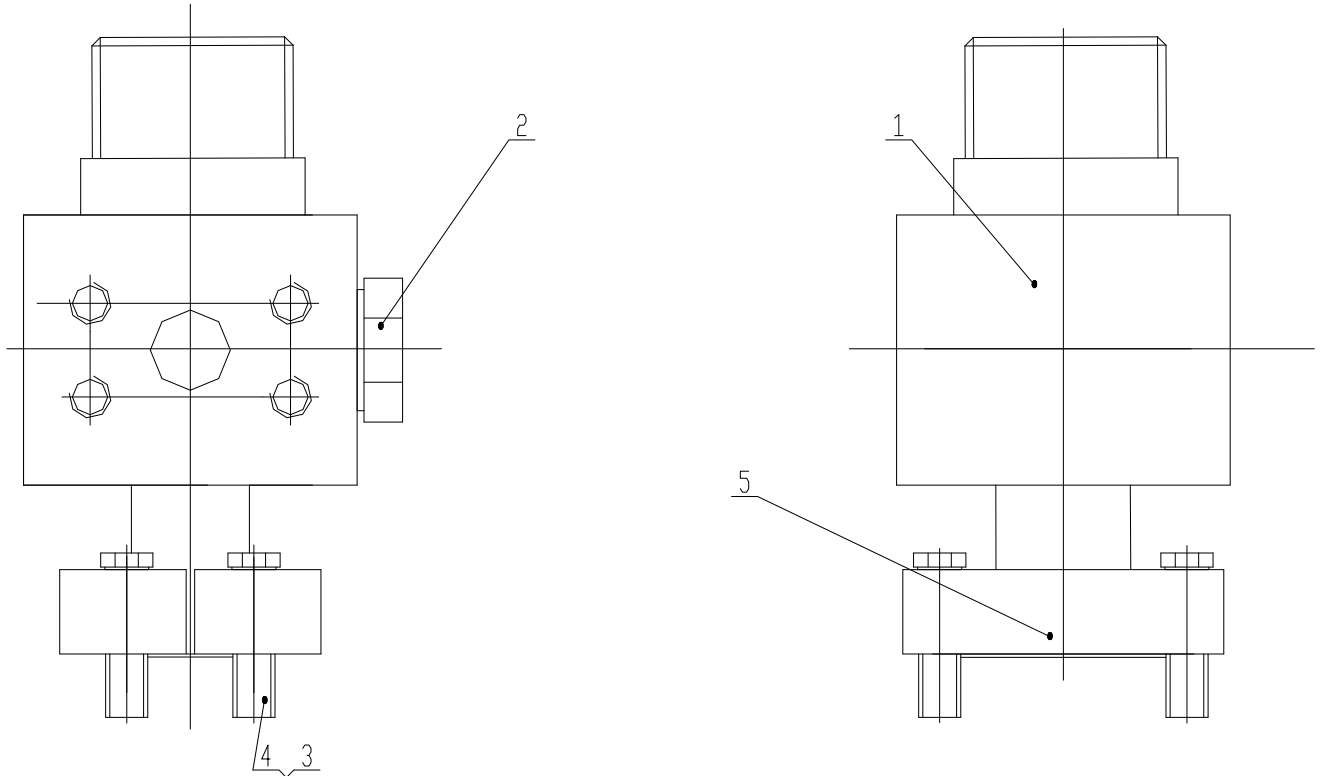

## Z38G0805T1 汇流座总成 Confluence Body Valve

序号 Item	代号 Part No.	名称 Parts Name		数量 Q'ty	备注 Remark
1	Z38G080501T1	汇流座	Confluence Body	1	
2	4MN-14WDZ	堵头	Connector	1	
3	GB/T 5783-2000	螺栓M10X30	Bolt M10X30	4	
4	GB/T93-1987	垫圈10	Washer 10	4	
5	FL-20Z	法兰	Connector	1	

# CG935GS- ZX1/ZX2 左/右转向油缸总成 Steering Cylinder

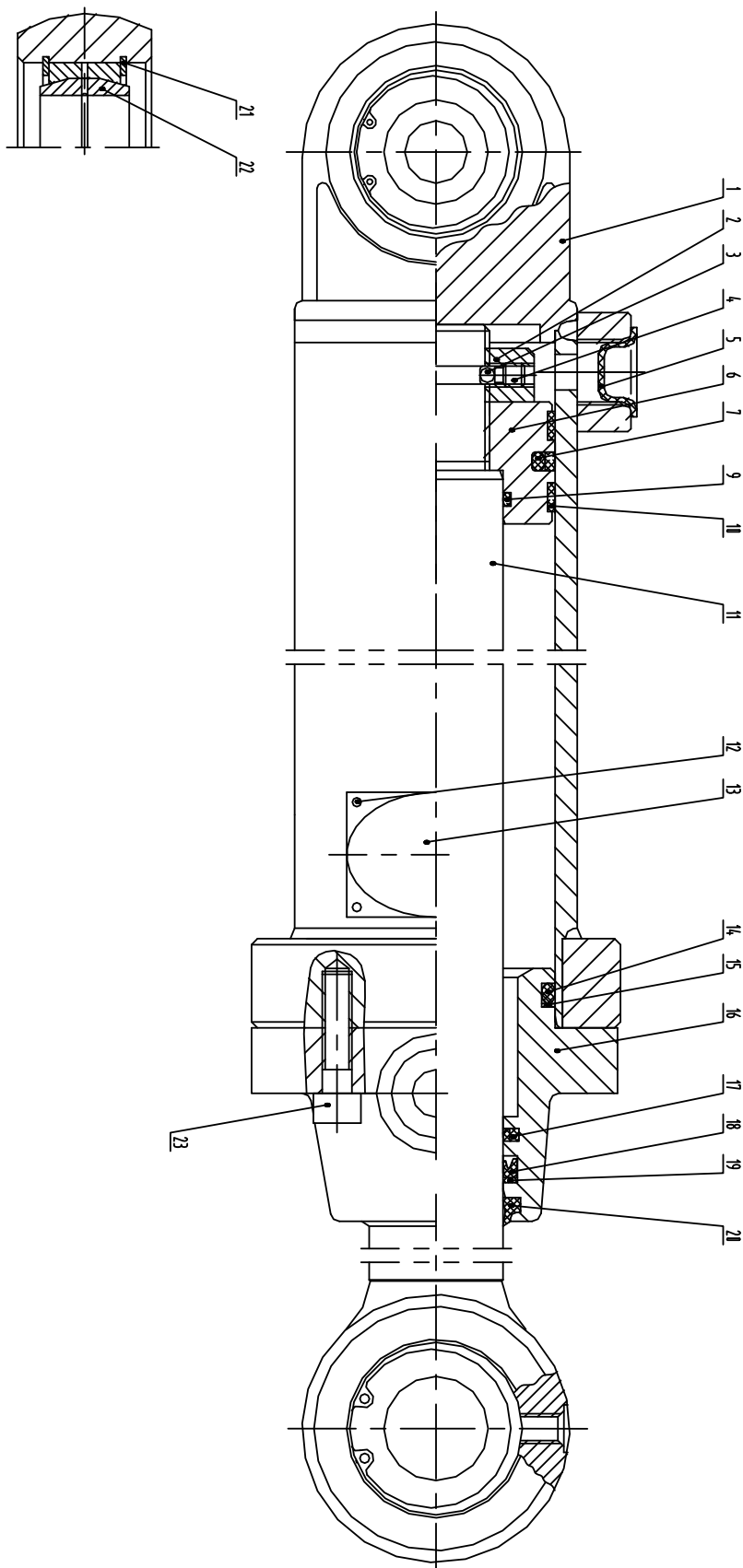

## CG935GS- ZX1/ZX2 左/右转向油缸总成 Steering Cylinder

序号 Item	代 号 Part No.	名 称 Parts Name	数 量 Q'ty	备注 Remark
1	ZL35F80/45.1.00	缸体 Cylinder	1	
2	JB/ZQ3876-86	防尘塞 20.5 Dustproof stuff 20.5	2	
3	ZL30.8.3f-1	螺母 nut	1	
4	GB/T308	钢球 $\phi 5$ Steel ball $\phi 5$	1	
5	GB97-85	螺钉 M8X10 Bolt M8X10	1	
6	ZL30.8.3f-2	活塞 Pston	1	
7	CKW0800	孔用组合密封 Hole rproof	1	
9	GB1235-76	O 形密封圈 $\phi 50X3.1$ O_Ring $\phi 50X3.1$	1	
10		支承环 80X9.5X2.5 Trestle table80X9.5X2.5	2	
11	ZL35F80/45.2.00	活塞杆 Pole pston	1	
12	GB109-86	铆钉 $\phi 2X4$ Rivet $\phi 2X4$	4	
13	Q/CGY MP-01	铭牌 Nameplate	1	
14	GB1235-76	O 形密封圈 $\phi 80X5.7$ O_Ring $\phi 80X5.7$	1	
15	ZL30.8.3f-3	挡圈 $\phi 80X \phi 71X2$ Snap Ring $\phi 80X \phi 71X2$	1	
16	ZL35F80/45-1	缸盖 Lid	1	
17	CKS0450	轴用组合密封 Axile rproof	1	
18		拉杆封 45X55X6 Quoit45X55X6	1	
19	ZL30.8.3f-4	挡圈 $\phi 54.7X \phi 45X3$ Snap Ring $\phi 54.7X \phi 45X3$	1	
20	K45	CK 型防尘圈 Quoit	1	
21	GB893.1-86	挡圈 55 Snap Ring55	4	
22	GB304.5-81	关节轴承 GE35ES AxletreeGE35ES	2	
23	GB70-86	螺钉 M10X40 Bolt M10X40	6	



# 制动系统

Braking System

# Z38G09T2 制动系统 Braking System

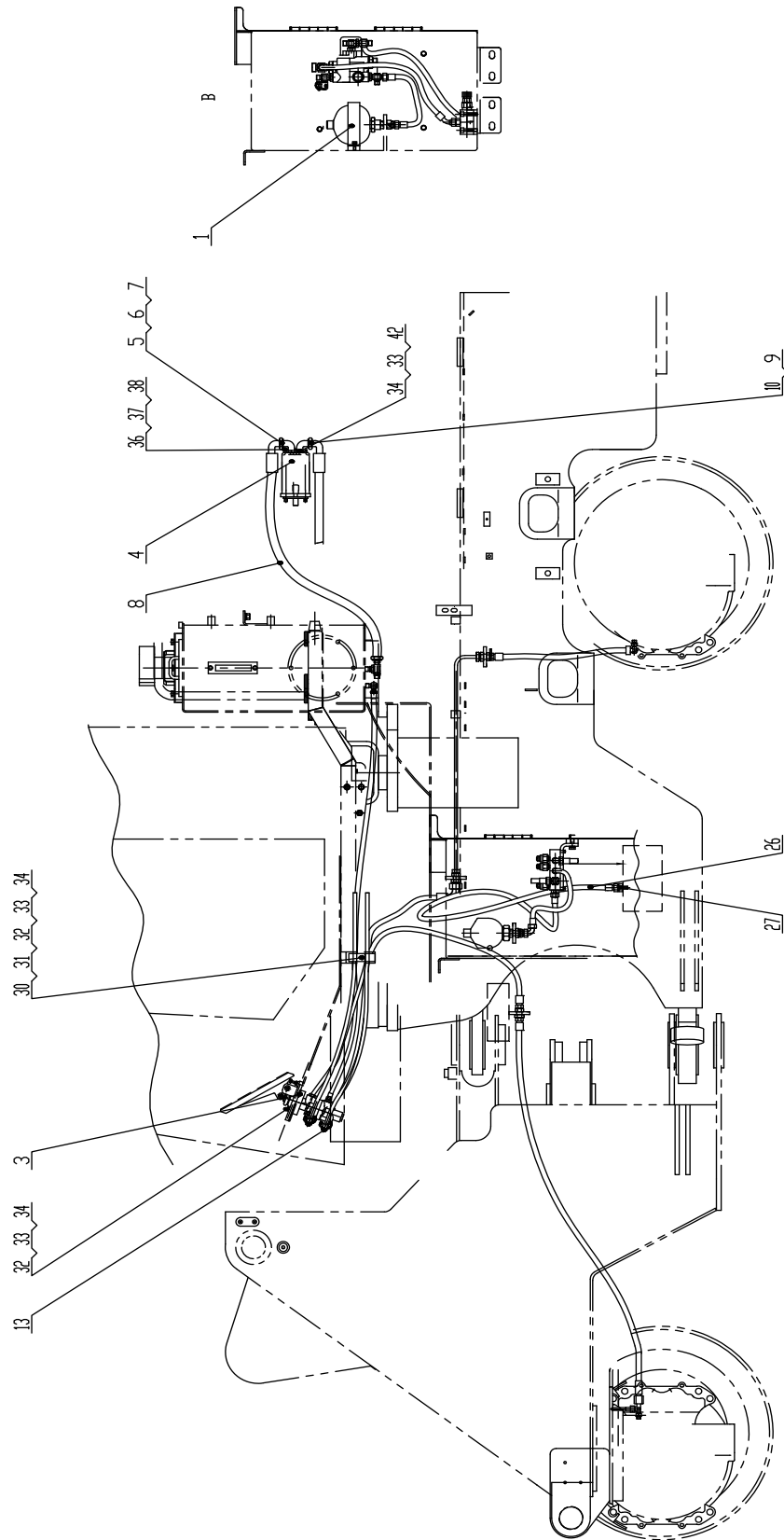

# Z38G09T2 制动系统 Braking System

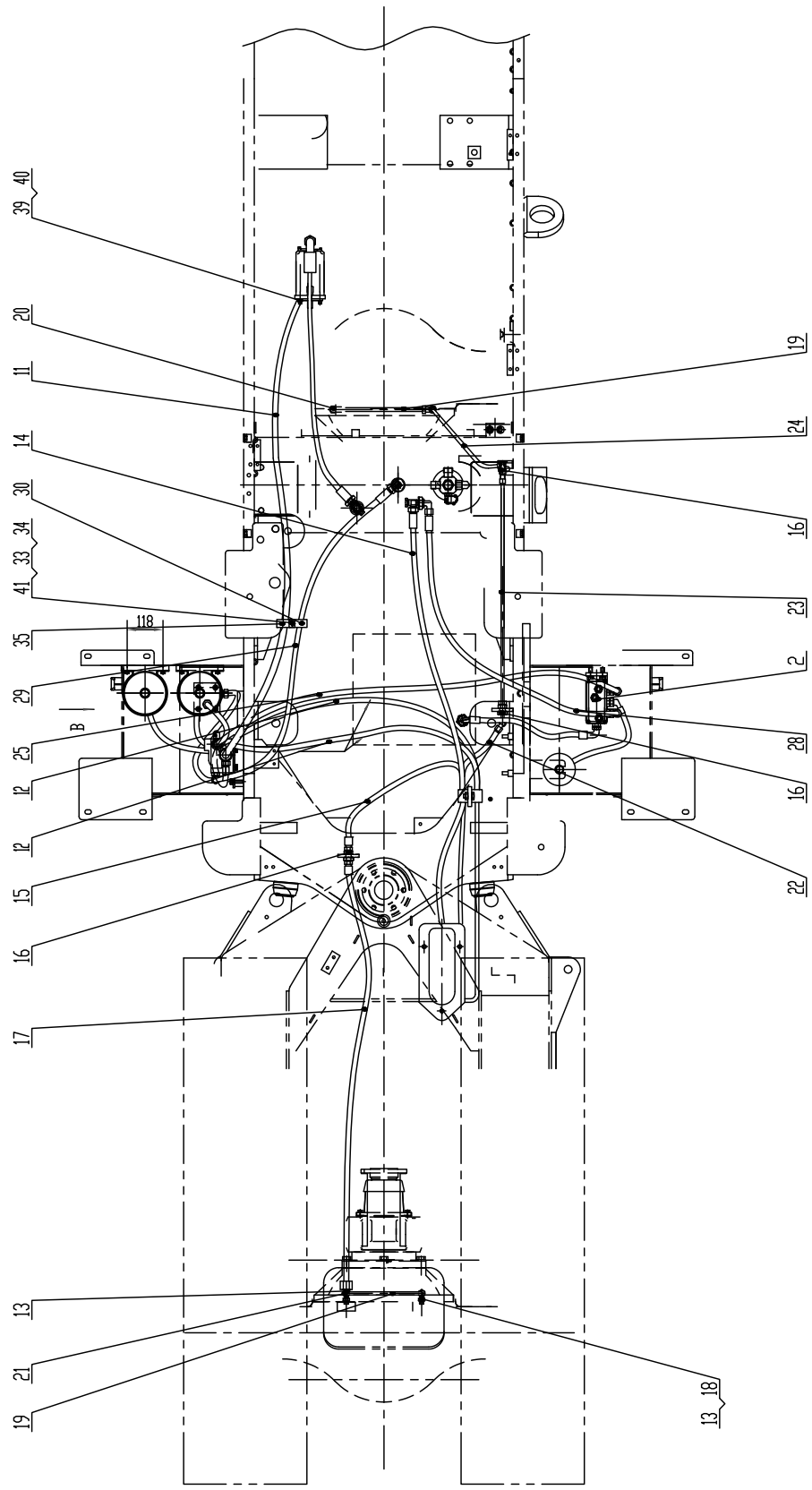

## Z38G09T2 制动系统 Braking System

序号 No.	代号 Part No.	名称 Parts Name	数量 Qty	备注 Remark
1	Z38G0901T2	右箱制动元件 Valve Assembly	1	
2	Z38G0902T2	左箱制动元件 Valve Assembly	1	
3	Z38G0903T2	脚制动阀总成 Service Brakes	1	
4	CBQZ-F525-A $\phi$ L	制动泵 pump	1	
5	1CFL9-36-20Z	法兰弯头 Connector	1	
6	FL-20Z	法兰 Connector	1	
7	2C9-36Z	弯头 Connector	1	
8	20411-36-12Z/20441-36-12Z X1T12X840	胶管总成 Hose	1	
9	1DFL9-30-12Z	法兰弯头 Connector	1	
10	FL-12Z	法兰 Connector	1	
11	20591-30-12Z/20511-30-12Z X2T12X1580	胶管总成 Hose	1	
12	20491-18-05Z/20411-18-05Z X2T05ITX1880	胶管总成 Hose	2	
13	2C9-18Z	过渡接头 Connector	2	
14	20411-18-05ZX1T05ITX1600	胶管总成 Hose	1	
15	20411-18-05Z/20491-18-05Z X1T05ITX830	胶管总成 Hose	1	
16	6C-18LNZ	过渡接头 Connector	3	
17	20411-18-05ZX1T05ITX2080	胶管总成 Hose	1	
18	1CH-18-14Z	过渡接头 Connector	2	
19	Z35F0905L	弯管总成 Steel tube	2	
20	1CH9-18-140GZ	可调向弯头 Connector	2	
21	BC-18Z	三通接头 Connector	2	
22	20411-18-05Z/20441-18-05Z X1T05ITX1050	胶管总成 Hose	1	
23	Z38G0904T1	钢管总成 Steel tube	1	
24	20411-18-05Z/20491-18-05Z X1T05ITX530	胶管总成 Connector	1	
25	20491-18-05Z/20411-18-05Z X1T05ITX2100	胶管总成 Hose	1	
26	20411-18-05Z/20491-18-05Z X1T05ITX1540	胶管总成 Hose	1	
27	1CM-18-10WDZ	过渡接头 Connector	1	

## Z38G09T2 制动系统 Braking System

序号 No.	代号 Part No.	名称 Parts Name		数量 Qty	备注 Remark
28	20491-18-06Z/20411-18-06ZX1T06ITX1530	胶管总成	Hose	1	
29	20411-18-06Z/20491-18-06ZX106ITX1580	胶管总成	Hose	1	
30	K0608-18Z	管夹	Clip	5	
31	GB/T 6170-2000	螺母 M8	Nut M8	1	
32	GB/T 5783-2000	螺栓 M8X35	Bolt M8X35	4	
33	GB/T 93-1987	垫圈 8	Washer 8	9	
34	GB/T 97.1-2000	垫圈 8	Washer 8	9	
35	K0608-24Z	管夹	Clip	1	
36	GB/T 5783-2000	螺栓 M10x30	Bolt M10X35	4	
37	GB/T 93-1987	垫圈 10	Washer 8	4	
38	GB/T 97.1-2002	垫圈 10	Washer 10	4	
39	GB/97.1-2002	垫圈 12	Washer 12	2	
40	GB/T 70.1-2000	螺钉 M12x30	Bolt M12X30	2	
41	GB/T 5783-2000	螺栓 M8X16	Bolt M8X16	1	
42	GB/T 5783-2000	螺栓 M8X30	Bolt M8X30	4	

# Z38G0901T2 右箱制动元件 Valve Assembly

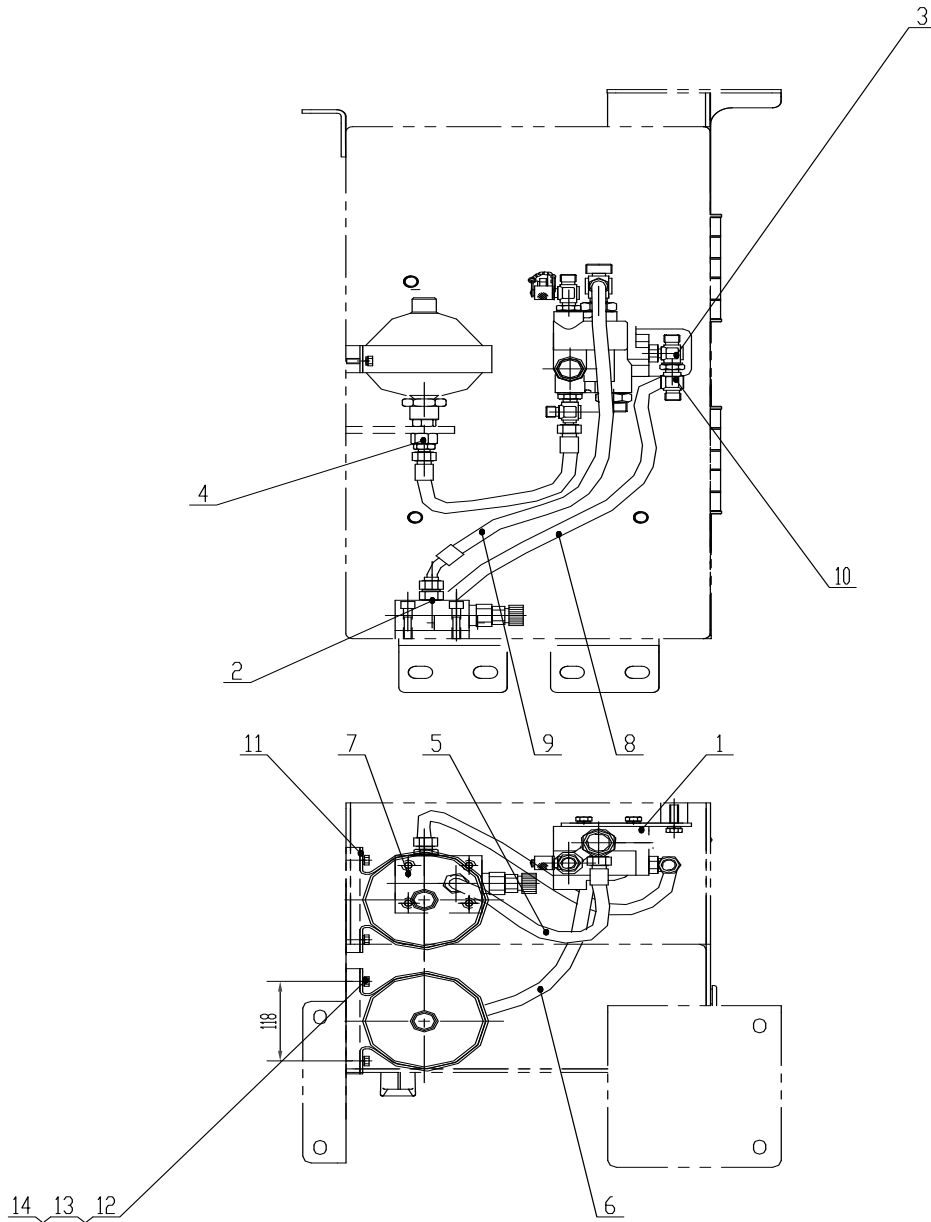

## Z38G0901T2 右箱制动元件 Valve Assembly

序号 No.	代号 Part No.	名称 Parts Name	数量 Qty	备注 Remark
1	Z38G090101T2	充液阀总成 Control manifold Assembly	1	
2	Z38G090102T2	溢流阀总成 safety valve	1	
3	BC-18Z	三通接头 Connector	1	
4	6GC-08-18LNZ	隔壁接头 Connector	2	
5	20411-18-05ZX1T05ITX420	胶管总成 Hose	1	
6	20411-18-05ZX1T05ITX540	胶管总成 Hose	1	
7	SB0210-1E1/112U-200AK55	蓄能器 accumulators	2	
8	20491-18-05ZX1T05ITX470 V0	胶管总成 Hose	1	
9	20441-18-05Z/20411-18-0 5ZX1T05ITX600	胶管总成 Hose	1	
10	CC-18Z	三通接头 Connector	1	
11	Z38G090102T1	管夹 Clip	2	
12	GB/T 93-1987	垫圈 8 Washer 8	4	
13	GB/T 97.1-2002	垫圈 8 Washer 8	4	
14	GB/T 5783-2000	螺栓 M8X16 Bolt M M8X16	4	

## Z38G090101T2 充液阀总成 Control manifold Assembly

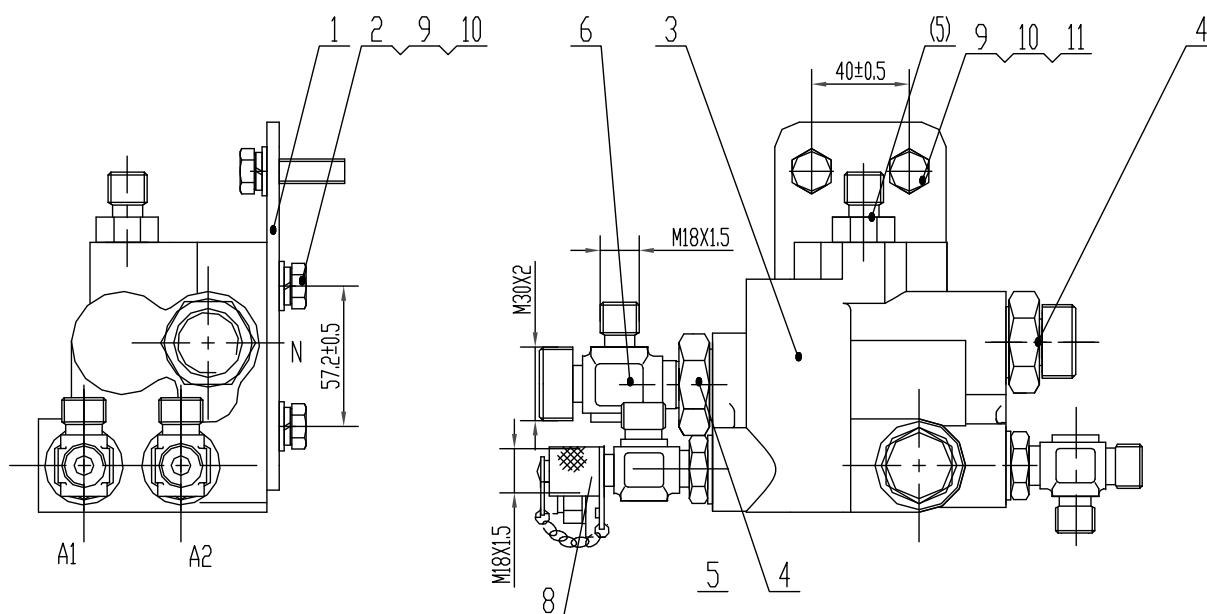

## Z38G090101T2 充液阀总成 Control manifold Assembly

序号 No.	代号 Part No.	名称 Parts Name	数量 Qty	备注 Remark
1	Z50G090102001T15	充液阀支板 board	1	
2	Z30090100008	螺栓 Bolt	2	
3	06-463-200	充液阀 Control manifold	1	
4	1D0-30-12Z	过渡接头 Connector	2	
5	1C0-18-08Z	过渡接头 Connector	4	
6	CDCD-30-18-30Z	过渡接头 Connector	1	
7	CC-18Z	过渡接头 Connector	3	
8	20C-08-12Z1-908-06-20-010Z	测压接头 Connector	1	
9	GB/T 97.1-2002	垫圈 10 Connector	4	
10	GB/T 93-1987	垫圈 10 Washer 10	4	
11	GB/T 5783-2000	螺栓 M10X35 Bolt M10X35	2	



# 06-463-200 充液阀 Control manifold

- Items included in repair kit  
 \* Not used in all models

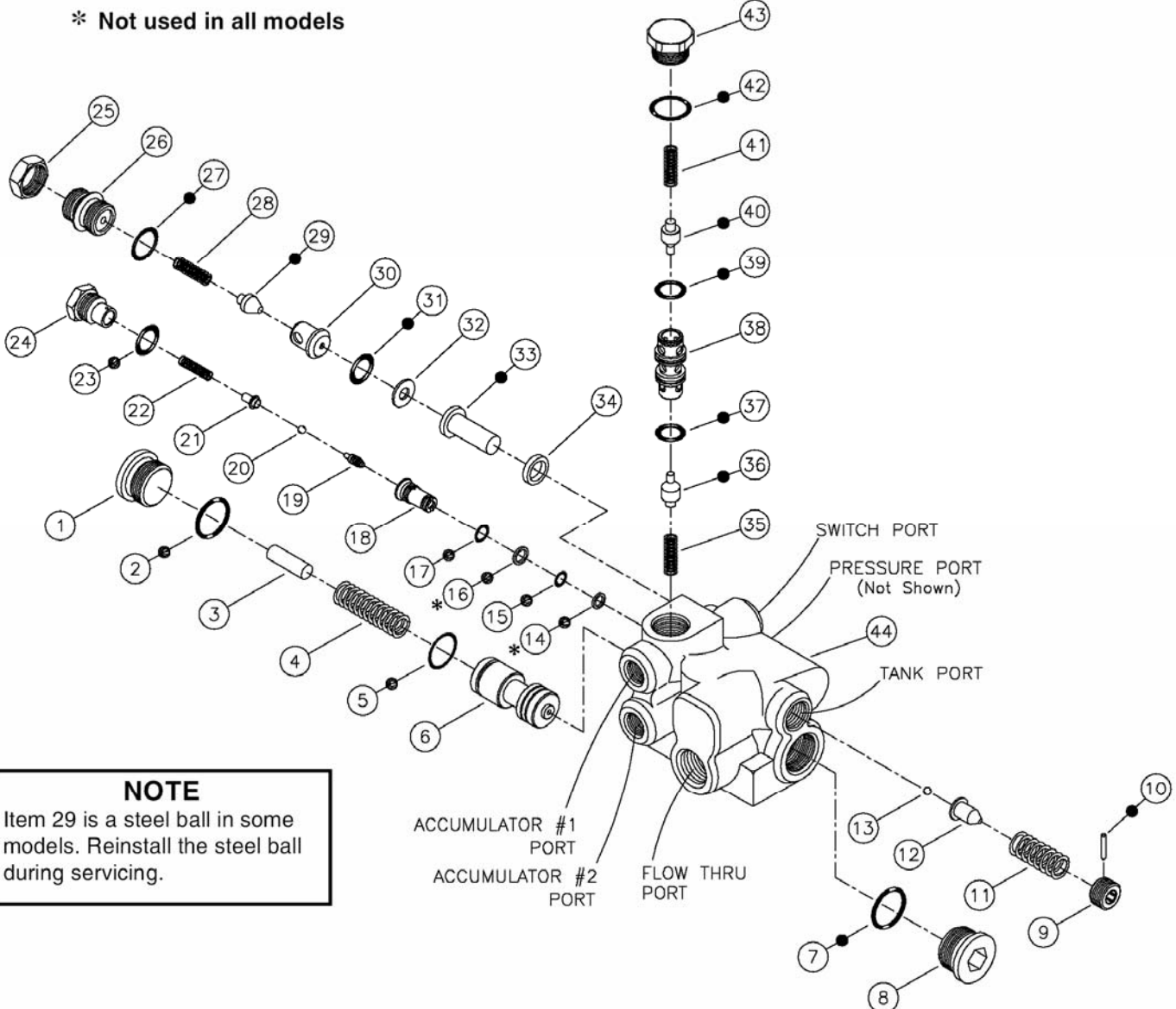

**NOTE**  
 Item 29 is a steel ball in some models. Reinstall the steel ball during servicing.

06-463-200 充液阀 Control manifold

序号 Item	代号 Part No.	名 称 Parts Name	数量 Q'ty	备注 Remark
1		堵头	Plug	1
2		O形圈	O-Ring	1
3		阀芯	Spool	1
4		弹簧	Spring	1
5		O形圈	O-Ring	1
6		顶杆	Pole	1
7		O形圈	O-Ring	1
8		堵头	Plug	1
9		丝堵	Plug	1
10		销子	Pin	1
11		弹簧	Spring	1
12		阀芯	Spool	1
13		滚珠	Ball bearing	1
14		垫圈	Washer	1
15		O形圈	O-Ring	1
16		垫圈	Washer	1
17		O形圈	O-Ring	1
18		阀芯	Spool	1
19		顶杆	Pole	1
20		滚珠	Ball bearing	1
21		顶杆	Pole	1
22		弹簧	Spring	1
23		O形圈	O-Ring	1
24		丝堵	Plug	1
25		螺帽	Screw cap	1
26		丝堵	Plug	1
27		O形圈	O-Ring	1
28		弹簧	Spring	1
29		顶杆	Pole	1
30		阀芯	Spool	1
31		O形圈	O-Ring	1
32		垫圈	Washer	1
33		顶杆	Pole	1
34		阀芯座	Spool Seat	1
35		弹簧	Spring	1

06-463-200 充液阀 Control manifold

序号 Item	代号 Part No.	名 称 Parts Name		数量 Q'ty	备注 Remark
36		顶杆	Pole	1	
37		O形圈	O-Ring	1	
38		阀芯	Spool	1	
39		O形圈	O-Ring	1	
40		顶杆	Pole	1	
41		弹簧	Spring	1	
42		O形圈	O-Ring	1	
43		丝堵	Plug	1	
44		阀体	Valve Body	1	

Z38G090102T2 溢流阀总成 Safety valve

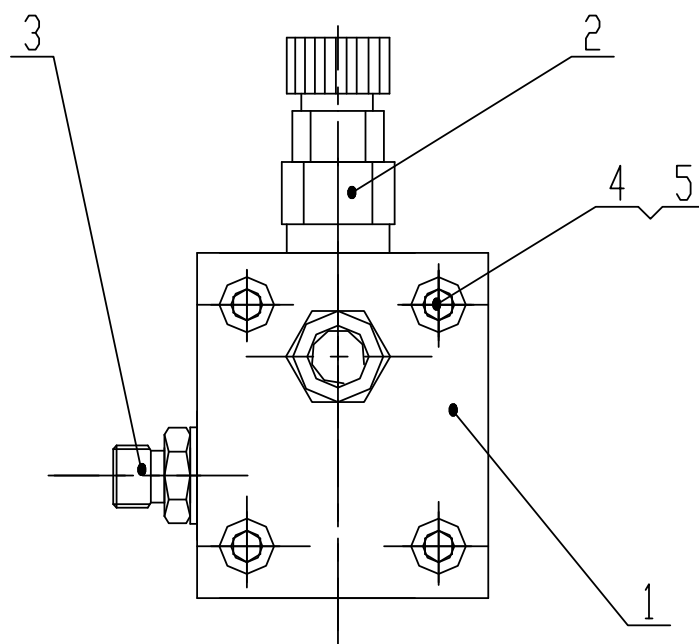

Z38G090102T2 溢流阀总成 Safety valve

序号 Item	代号 Part No.	名 称 Parts Name	数量 Q'ty	备注 Remark
1	P165. 40. 11-2	阀座 Valve body	1	
2	DB10K2-40B/200Y	溢流阀 Safety valve	1	
3	1CH-18Z	过渡接头 Connector	2	
4	GB/T 70.1-2002	螺钉M10X55 Bolt M10X55	4	
5	GB/T 93-1987	垫圈10 Washer 10	4	

## Z38G0902T2 左箱制动元件 Valve Assembly

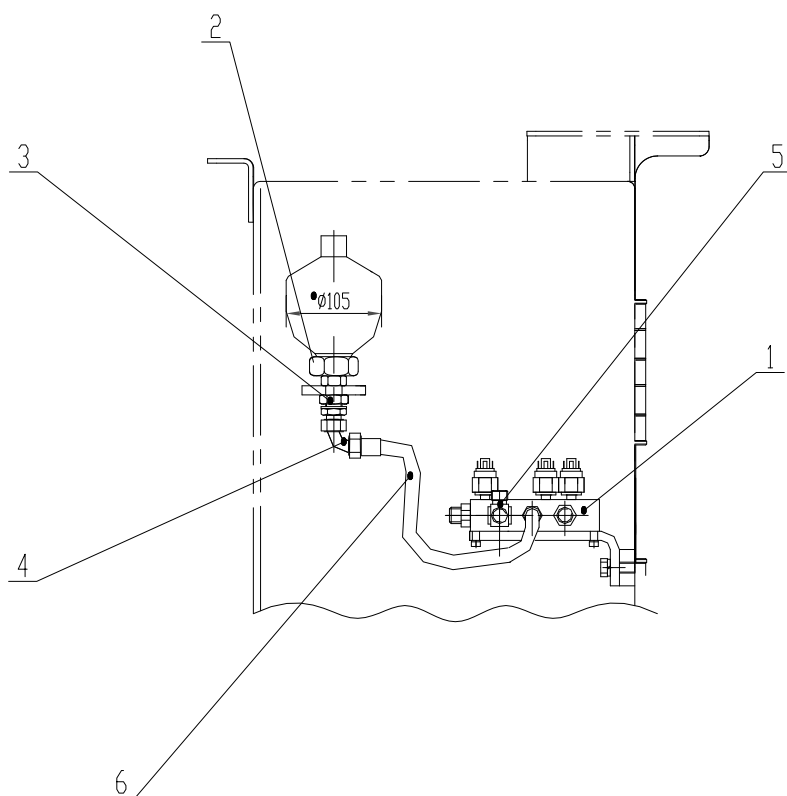

## Z38G0902T2 左箱制动元件 Valve Assembly

序号 Item	代号 Part No.	名 称 Parts Name		数量 Q'ty	备注 Remark
1	Z38G090201T1	集成阀总成	Valve	1	
2	SB0210-0.5E1/112U-20 0AK	停车蓄能器	accumulators	1	
3	6CG-18-08LN	隔壁接头	Connector	1	
4	2C9-18Z	弯头	Connector	1	
5	BC-18Z	三通接头	Connector	1	
6	20491-18-05ZX1T05ITX 360V0	胶管总成	Hose	1	

## Z38G090201T2 集成阀总成 Valve Assembly

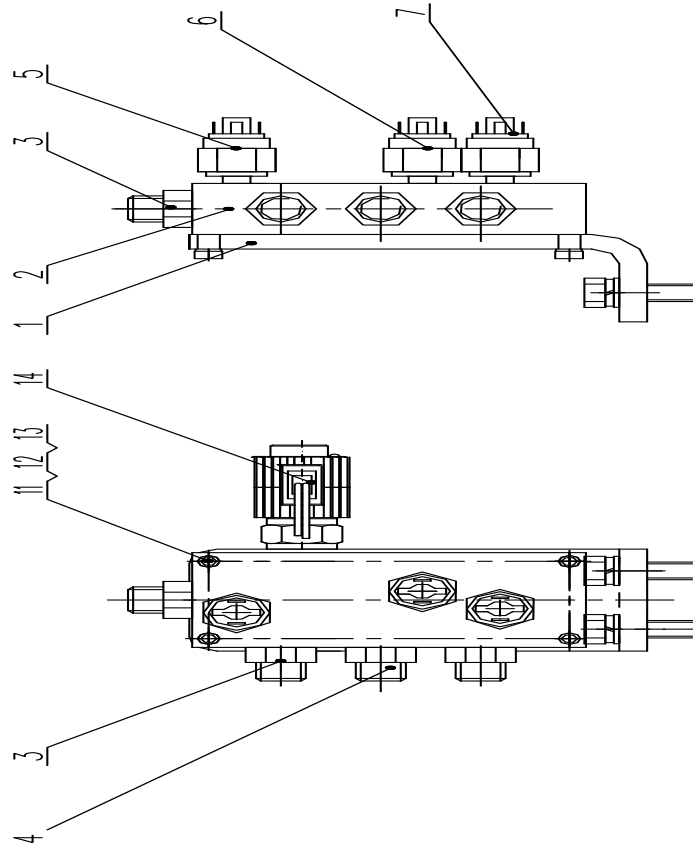

## Z38G090201T2 集成阀总成 Valve Assembly

序号 No.	代号 Part No.	名称 Parts Name	数量 Qty	备注 Remark
1	Z50G090101001T15	集成阀支架底板 board	1	
2	M22362	制动阀块总成 Valve	1	
3	1C0-18-08	过渡接头 Connector	3	
4	1CN-18-12	过渡接头 Connector	1	
5	PS61-50-2MNZ-B-SP-RB- FS122BarF	停车制动指示灯开关 Press on-off	1	
6	PS61-50-2MNZ-A-SP-RB- FS69BarF	紧急制动压力开关 Press on-off	1	
7	PS61-50-2MNZ-B-SP-RB- FS120BarF	低压报警开关 Press on-off	1	
8	GB/T 5783-2000	螺栓 M10X30 Bolt M10X30	2	
9	GB/T93-1987	垫圈 10 Washer 10	2	
10	GB/T97.1-2002	垫圈 10 Washer 10	2	
11	GB/T 5783-2000	螺栓 M5X50 Bolt M5X50	4	
12	GB/T 93-2000	垫圈 5 Washer 5	4	
13	GB/T 97.1-2000	垫圈 5 Washer 5	4	
14	M22362-2	电磁阀 Valve	1	

## Z38G0903T2 脚制动阀总成 Service Brakes

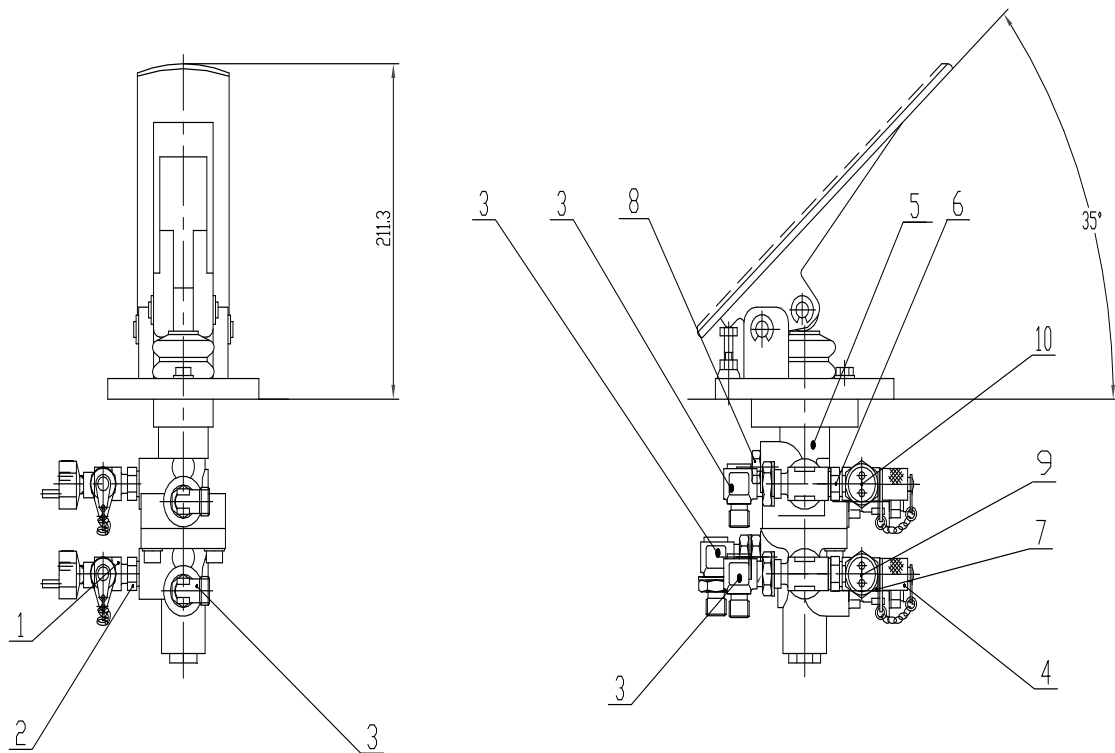

Z38G0903T2 脚制动阀总成 Service Brakes

序号 No.	代号 Part No.	名称 Parts Name	数量 Qty	备注 Remark
1	BC-18Z	三通接头 Connector	2	
2	1C0-18-06Z	端直通接头 Connector	5	
3	2C9-18Z	直角接头 Connector	5	
4	1-906-24-30-010Z	测压接头 Connector	2	
5	06-466-218	脚制动阀 Service Brakes	1	
6	2HC-16-18Z	直接头体 Connector	2	
7	GHNH-16-02-14CGZ	三通接头体 Connector	2	
8	Z30090200004	螺塞 bolt	1	
9	PS61-15-2MNZ-A-SP-RB- FS5	行车制动灯开关 Press on-off	1	
10	PS61-30-2MNZ-A-SP-RB- FS3	切断动力开关 Press on-off	1	

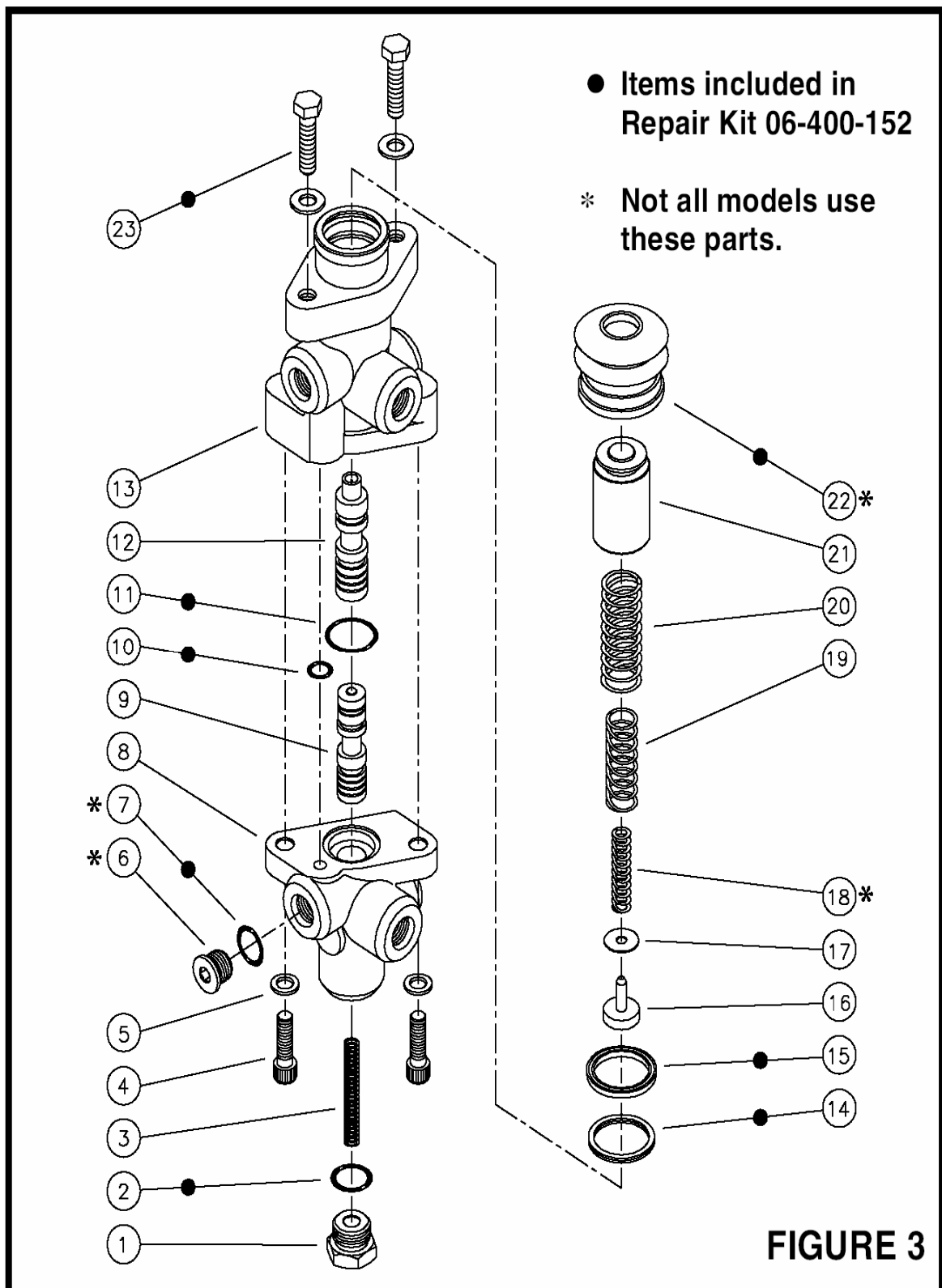

FIGURE 3



## 06-466-218 脚制动阀 Service Brakes

序号 Item	代号 Part No.	名 称 Parts Name	数量 Q'ty	备注 Remark
1		丝堵	Plug	1
2		O形圈	O-Ring	1
3		弹簧	Spring	1
4		螺栓	Bolt	2
5		垫圈	Washer	2
6		丝堵	Plug	1
7		O形圈	O-Ring	1
8		阀体	Valve Body	1
9		阀芯	Spool	1
10		O形圈	O-Ring	1
11		O形圈	O-Ring	1
12		阀芯	Spool	1
13		阀体	Valve Body	1
14		密封	Seal	1
15		CUP	CUP	1
16		弹簧挡圈	Ring	1
17		垫片	Washer	1
18		弹簧	Spring	1
19		弹簧	Spring	1
20		弹簧	Spring	1
21		活塞	Piston	1
22		安全罩	Cover	1
23		螺钉	Screw	2

# 工作液压系统

## **Implement Hydraulic System**

# Z38G10T2 工作液压系统 Implement Hydraulic System

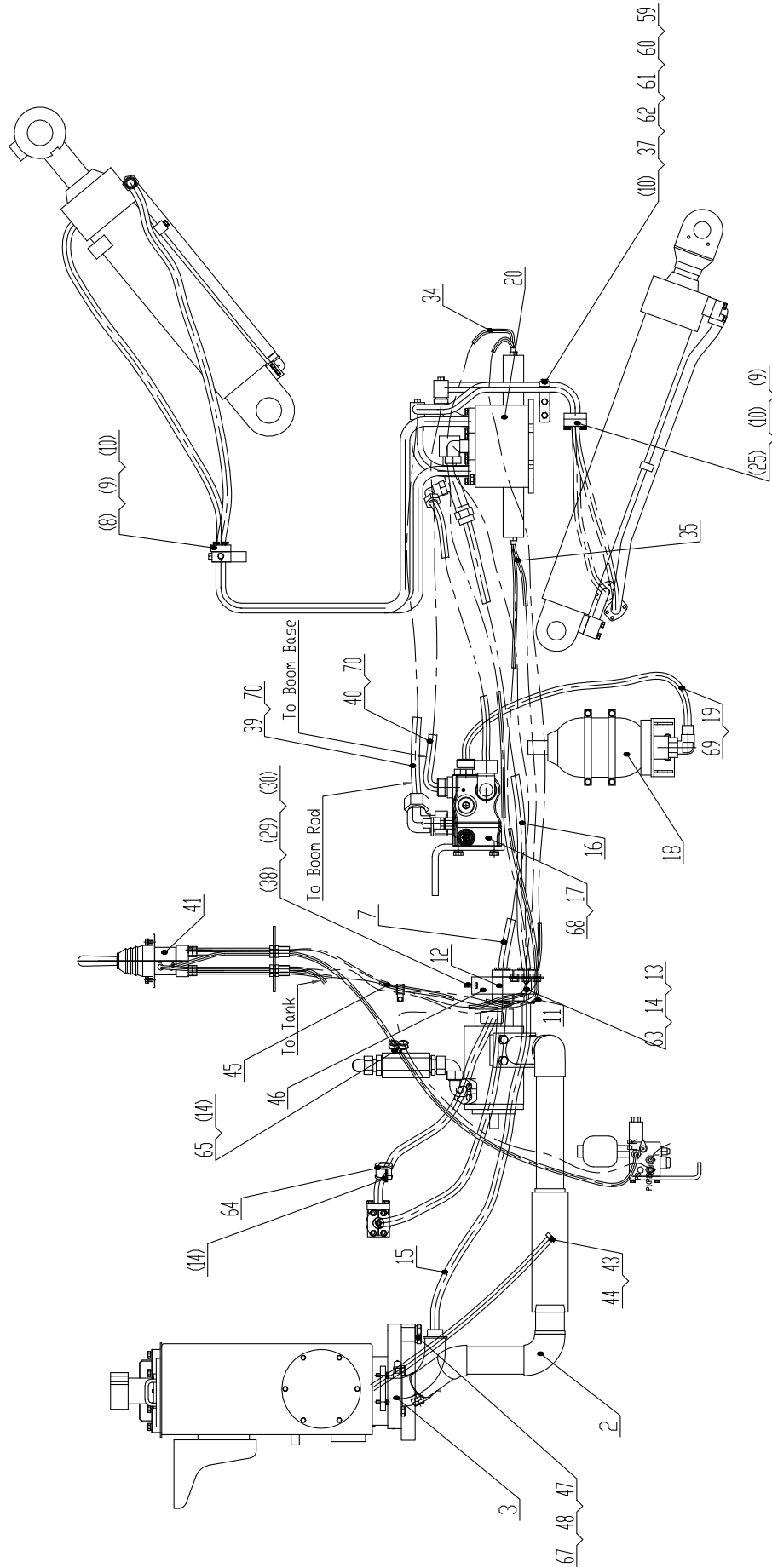

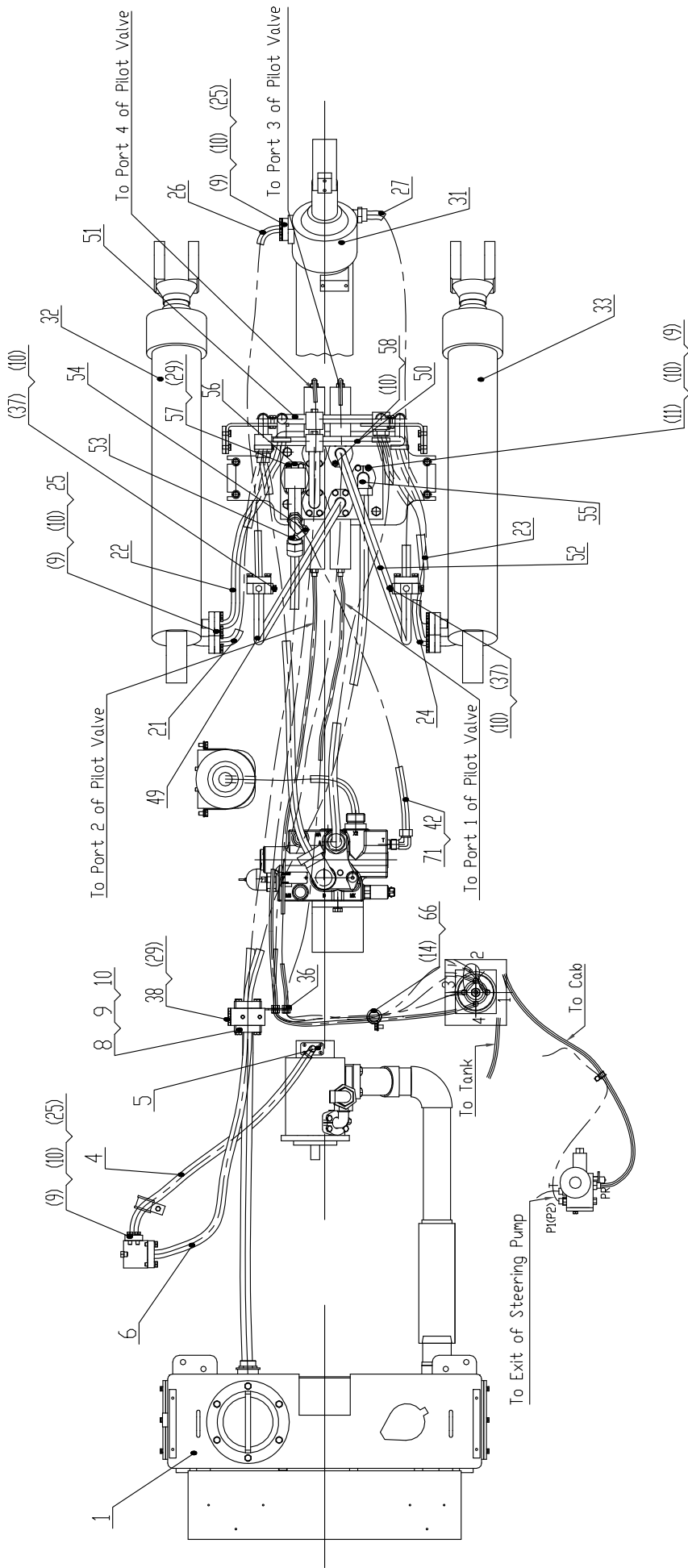

## Z38G10T2 工作液压系统 Implement Hydraulic System

序号 Item	代 号 Part No.	名 称 Parts Name	数量 Q'ty	备注 Remark
1	Z38G1001T2	液压油箱总成 Hydraulic Oil Tank	1	
2	Z38G1015T1	箱端吸油总成 Steel Tube Assembly	1	
3	Z38G1002T2	回油管总成 Steel Tube Assembly	1	
4	87392-12-12(H130)Z/87392-12-12ZX4 SP12X940V270	胶管 Hose	1	
5	FL-12Z (配 4 颗 3/8" X16-32 螺栓)	法兰接头 Flange	1	
6	20542-42-16TZ/87342-16-16ZX4SP16X 1010V270	胶管 Hose	1	
7	87342-16-16Z/20512-42-16ZX4SP16X1 360+RNL	胶管 Hose	1	
8	FL-16Z	法兰组件 Flange	4	
9	GB/T 5783-2000	螺栓 M10X30 Bolt	68	
10	GB/T 93-1987	垫圈 10 Washer	92	
11	FL-20Z	法兰组件 Flange	3	
12	Z38G100000001T1	进回油体 Flange	1	
13	Z38G100000002T1	过渡板 Plate	1	
14	GB/T 5783-2000	螺栓 M8X16 Bolt	5	
15	87341-20-20Z/20411-45-20TZ/20411-45-20ZX1T20X1 070	胶管 Hose	1	
16	20411-45-20TZ/87341-20-20ZX1T20X1 180RNL	胶管 Hose	1	
17	Z38G1004T1	稳定模块总成 Ride Control Valve Assembly	1	
18	Z38G1014T1	蓄能器总成 Accumulator Assembly	1	
19	20592-36-12TZ/4SH12X650V0/STC	胶管 Hose	1	
20	Z38G1003T1	多路阀总成 Multi-way valve Assembly	1	
21	87312-12-12Z/87392-12-12ZX4SH12X9 00RNLDCN	胶管 Hose	1	
22	87312-12-12Z/87392-12-12(H130)ZX4 SH12X1020RNLDCN	胶管 Hose	1	
23	87312-12-12Z/87392-12-12(H130)ZX4 SH12X1020RNLDCW	胶管 Hose	1	
24	87312-12-12Z/87392-12-12ZX4SH12X9 00RNLDCW	胶管 Hose	1	
25	FL-12Z	法兰组件 Flange	10	
26	87312-16-12Z/87392-12-12ZX4SH12X1 300DCW	胶管 Hose	1	

27	87312-16-12Z/20592-36-12TZ4SH12X 1270	胶管	Hose		1
28	GB/T 5783-2000	螺栓 M12X40	Bolt		4
29	GB/T 93-1987	垫圈 12	Washer		13
30	GB/T 97.2-2002	垫圈 12	Washer		6
31	Z38G1008T1	翻斗缸总成	Tilting Assembly	Cylinder	1
32	Z38G1006T1	左提升缸总成	Tilting Assembly	Cylinder	1
33	Z38G1007T1	右提升缸总成	Tilting Assembly	Cylinder	1
34	20491-16-04Z/20411-16-04ZX1T04ITX 1800	胶管	Hose		2
35	20441-16-04Z/20411-16-04ZX1T04ITX 1100	胶管	Hose		2
36	6C-16LNZ	接头	Connector		4
37	GB/T 5783-2000	螺栓 M10X20	Bolt		6
38	GB/T 5783-2000	螺栓 M12X25	Bolt		5
39	20512-36-16ZX4SH16X850	胶管	Hose		1
40	20512-36-16Z/20592-36-16ZX4SH16X8 70	胶管	Hose		1
41	Z38G1005T2	先导系统总成	Pilot Hydraulic System		1
42	20411-30-12ZX1T12X650	胶管	Hose		1
43	1CH-30-33FAZ	接头	Connector		1
44	20030-30-12FA	放油管	Hose		1
45	20491-16-04Z/20411-16-04ZX1T04X10 20	胶管	Hose		4
46	Z38G100000003T1	L 板	L Plate		1
47	GB/T 5783-2000	螺栓 M16X80	Bolt		4
48	GB/T 93-1987	垫圈 16	Washer		4
49	Z38G1009T1	翻斗小腔硬管总成	Steel Tube Assembly		1
50	Z38G1010T1	动臂小腔硬管总成	Steel Tube Assembly		1
51	Z38G1011T1	动臂大腔硬管总成	Steel Tube Assembly		1
52	Z38G1012T1	翻斗大腔硬管总成	Steel Tube Assembly		1
53	Z38G1013T1	多路阀 T 口总成	Multi-way valve T Meatus Assembly		1
54	2C9-30Z	接头	Connector		1
55	1DFL9-42-20Z	接头	Connector		1
56	FL-24Z	法兰组件	Flange		1

57	GB/T 5783-2000	螺栓 M12X35	Bolt	4
58	GB/T 5783-2000	螺栓 M10X35	Bolt	16
59	Z38G100000004T1	管夹	Tube Clip	2
60	Z38G100000005T1	支板	Plate	2
61	GB/T 6170-2000	螺母 M10	Nut	2
62	GB/T 5783-2000	螺栓 M10X25	Bolt	2
63	GB/T 93-1987	垫圈 8	Washer	2
64	K0608-32Z	R 管夹	R clip	1
65	K0608-12Z	R 管夹	R clip	2
66	K0608-35Z	R 管夹	R clip	1
67	GB/T 97. 2-2002	垫圈 16	Washer	4
68	Z38G1006T2	稳定模块总成	Ride Control Valve Assembly	1
69	20592-36-16ZX4SPX830V0	胶管	Hose	1
70	20512-36-16Z/20592-36-16ZX4SP16X7 80	胶管	Hose	2
71	87692-16-12Z/20491-30-12ZX1T12X55 0	胶管	Hose	1

# Z38G100T2 液压油箱总成 Hydraulic Oil Tank Assembly

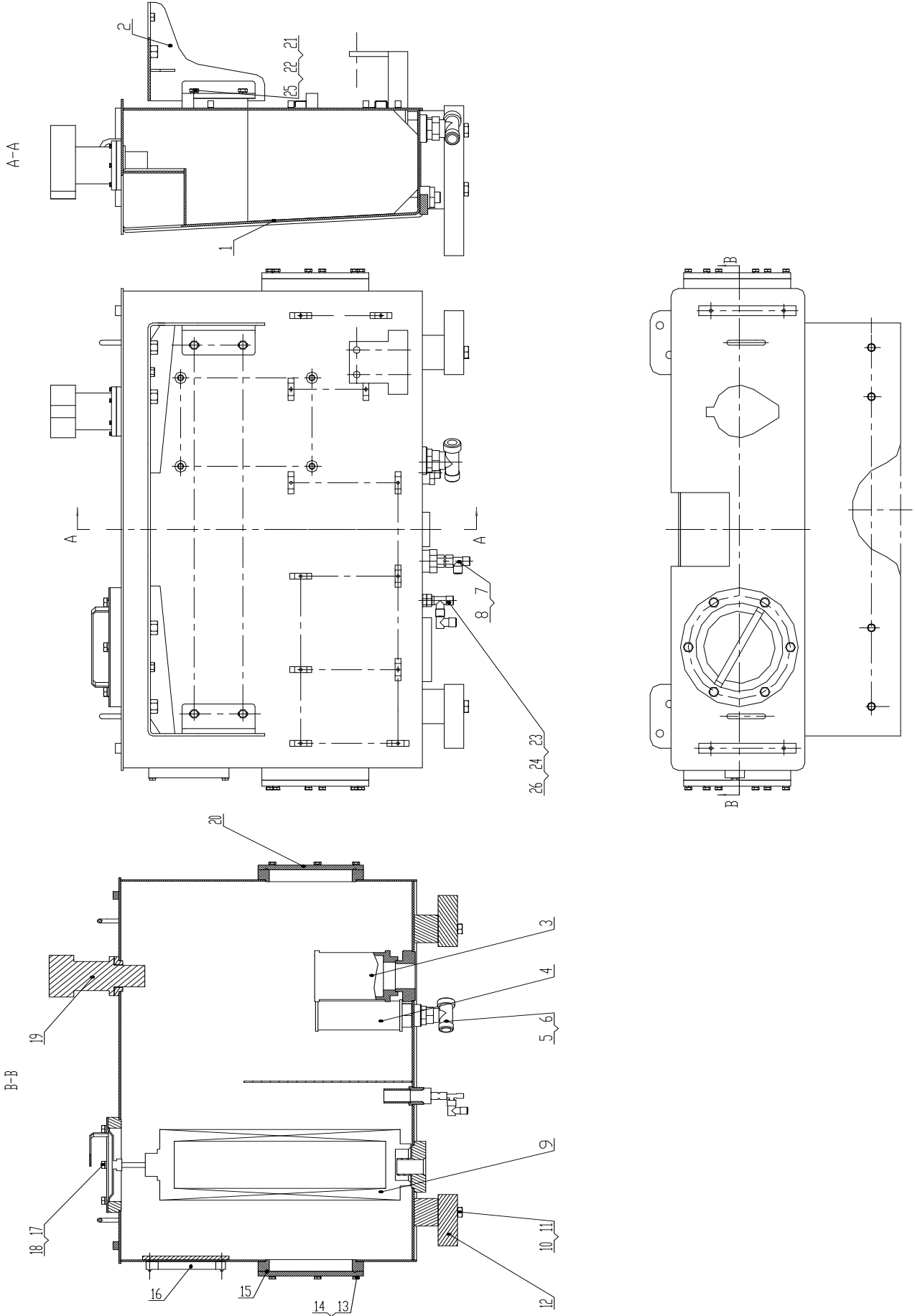



## Z38G1001T2 液压油箱总成 Hydraulic Oil Tank Assembly

序号 Item	代 号 Part No.	名 称 Parts Name	数量 Q'ty	备注 Remark	
1	Z38G100101T2	液压油箱	Hydraulic Oil Tank	1	
2	Z38G100102T2	机罩支撑板总成	Plate Assembly	1	
3	SFM-679A	吸油滤油器	Filter	1	
4	WU-160X100-J	制动泵吸油滤	Filter	1	
5	1CH-36-33Z	接头体	Connector	1	
6	BC-36Z	三通接头	Connector	1	
7	1CH-18-33Z	接头体	Connector	1	
8	CC-18Z	接头体	Connector	1	
9	TL352-10 (CK)	回油滤油器	Filter	1	
10	GB/T5783-2000	螺栓 M20X70	Bolt	4	
11	GB/T93-1987	垫圈 20	Washer	4	
12	Z38G100100001T2	油箱支座	Seat	2	
13	GB/T5783-2000	螺栓 M8X25	Bolt	12	
14	GB/T93-1987	垫圈 8	Washer	12	
15	GB/T3452.1-1992	O 型圈 180X3.55	O Ring	2	
16	YWZ-150A (刻度)	油标尺	Instrument	1	
17	GB/T5783-2000	螺栓 M12X25	Bolt	6	
18	GB/T93-1987	垫圈 12	Washer	6	
19	TK50F	空气滤清器	Air Cleaner	1	
20	Z50E100100007	清洗法兰	Flange	2	
21	GB/T5783-2000	螺栓 M10X25	Bolt	4	
22	GB/T93-1987	垫圈 10	Washer	4	
23	1CH-18-16Z	接头体	Connector	1	
24	CC-18Z	接头体	Connector	1	
25	GB/T97.2-2002	垫圈 10	Washer	4	
26	2C9-18Z	接头体	Connector	1	

# Z38G100101T2 液压油箱 Hydraulic Oil Tank

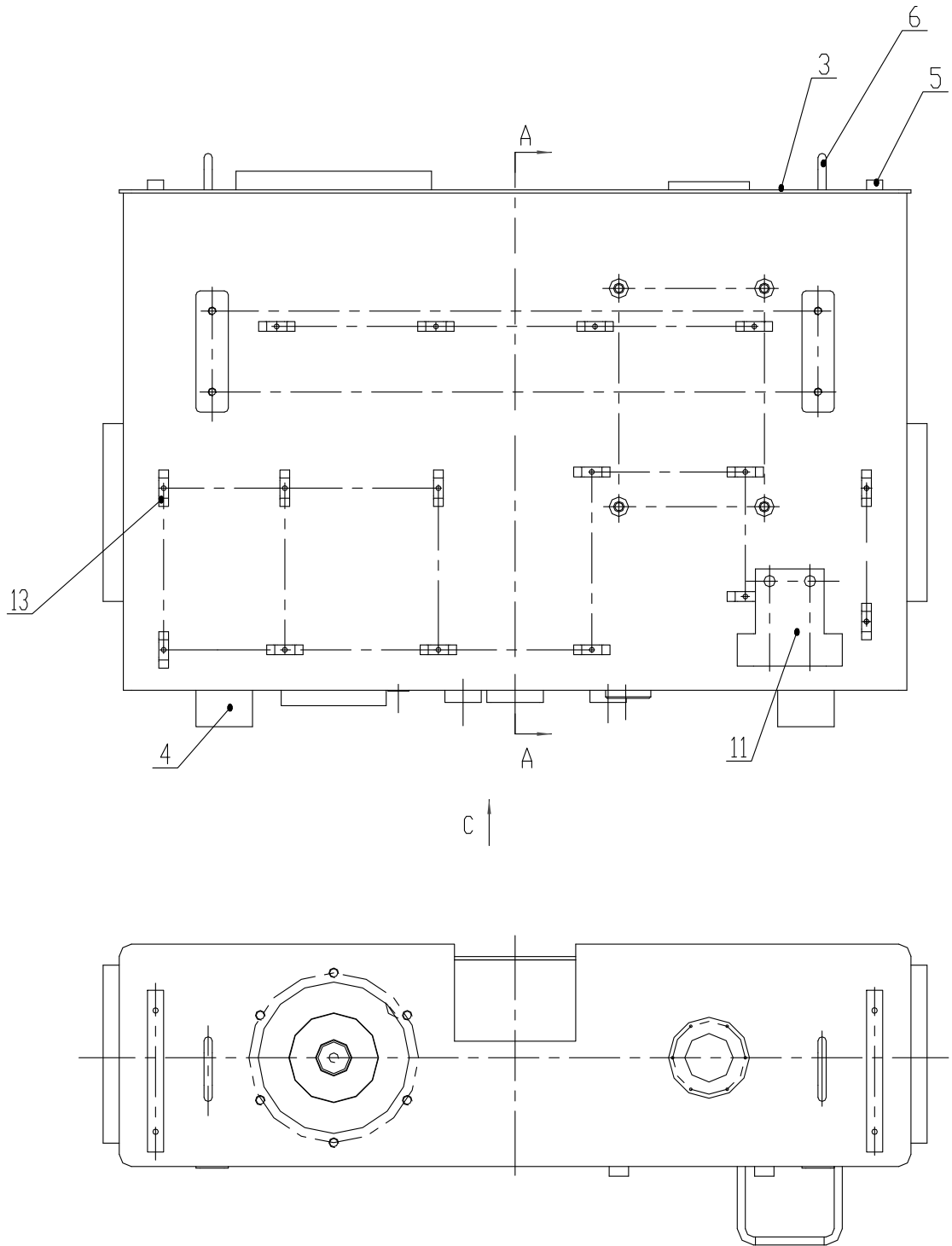

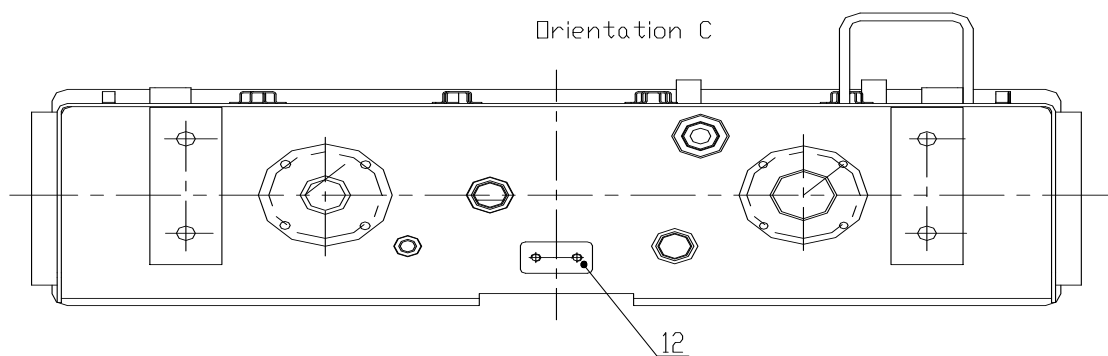
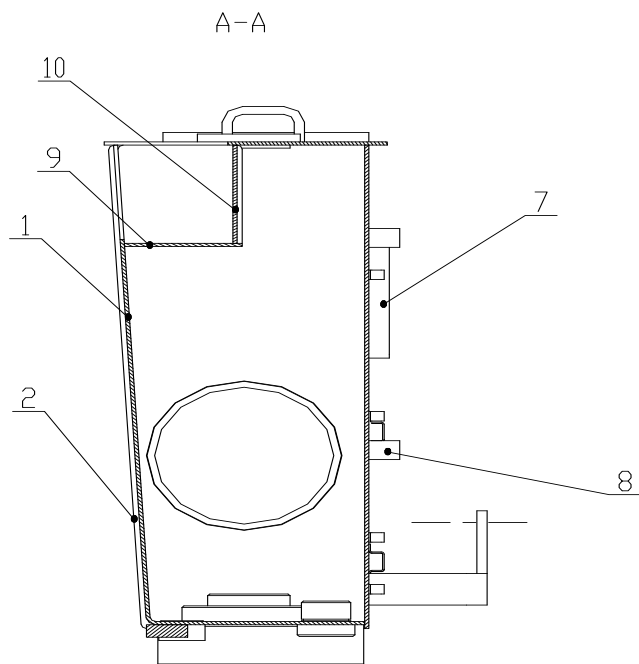

**Z38G100101T2 液压油箱 Hydraulic Oil Tank**

序号 Item	代 号 Part No.	名 称 Parts Name	数量 Q'ty	备注 Remark
1	Z38G1001011T2	L 板总成 L Plate Assembly	1	
2	Z38G1001012T2	侧围板总成 Plate	1	
3	Z38G1001013T2	盖板总成 Plate	1	
4	Z38G100100003T1	支座 Seat	2	
5	Z35C100100012	顶支板 1 Plate 1	2	
6	ZL40. 10. 1. 1-16	吊环 Flying rings	2	
7	Z38G100100004	连接板 Plate	2	
8	Z30100100012	座子 Seat	4	
9	Z38G100101001T2	围板 Plate	1	
10	Z38G100100002T1	封板 Plate	1	
11	P3B080100025T6	滤油器支架 Bracket	1	
12	Z50E120800001T46	三通支架垫板 Plate	1	
13	Z35G120901001T8	泡膜扣固定卡板 Plate	16	

## Z38G1001011T2 L 板总成 L Plate Assembly

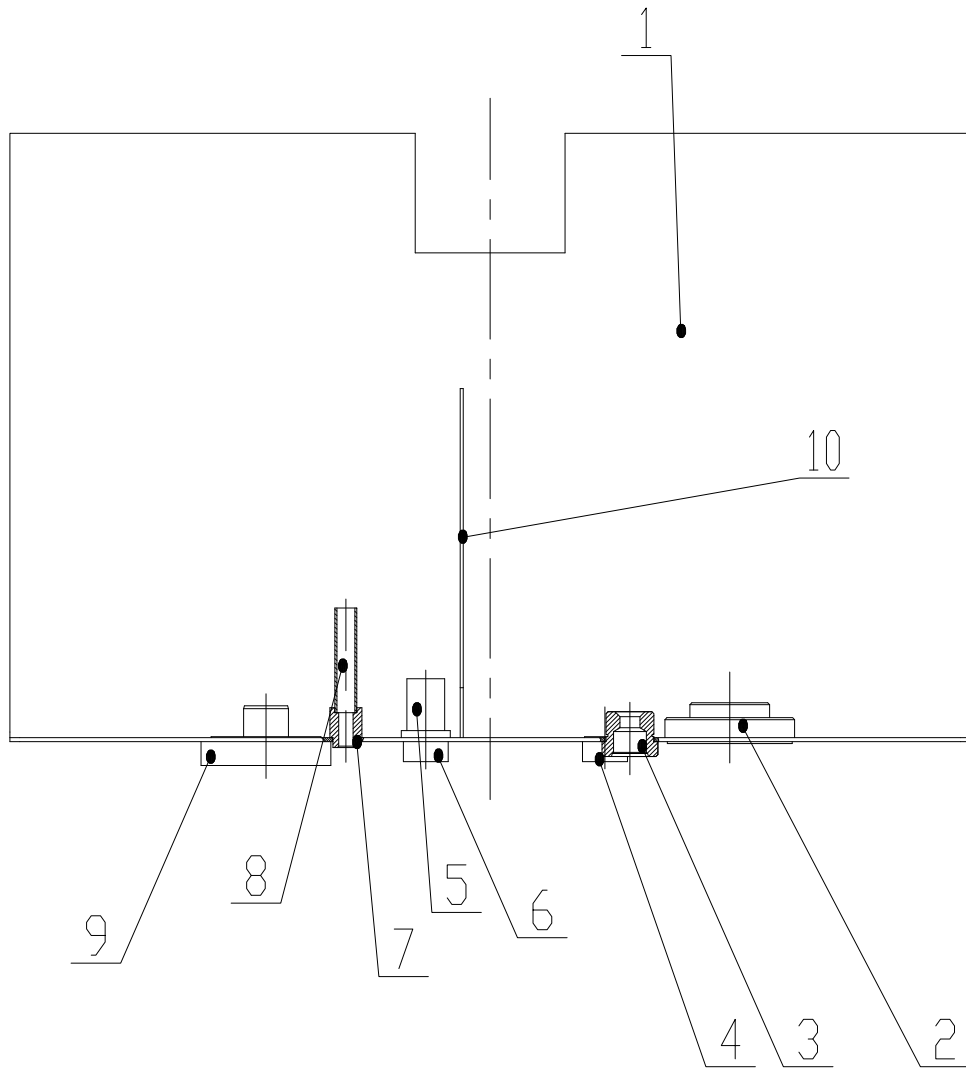

## Z38G1001011T2 L 板总成 L Plate Assembly

序号 Item	代 号 Part No.	名 称 Parts Name	数量 Q'ty	备注 Remark
1	Z38G100101101T2	L 板 L Plate	1	
2	Z35G100101004T4	吸油法兰座 Flange	1	
3	Y18J100100008	转向泵吸油接头 Connector	1	
4	Z30100100010A	放油接头座 Connector	1	
5	Z38G100101002	油管 Tube	1	
6	Z38G100101005	卸油接头座 Connector	1	
7	Z35F100100017A	回油接头座 Connector	1	
8	Z35G100101006T4	油管 1 Tube	1	
9	Z38G100101003	回油滤芯座 Seat	1	
10	Z38G100101102T2	隔板 Plate	1	

### Z38G1001012T2 侧围板总成 Plate Assembly



### Z38G1001012T2 侧围板总成 Plate Assembly

序号 Item	代 号 Part No.	名 称 Parts Name	数量 Q'ty	备注 Remark
1	Z38G100101101T2	L 板 L Plate	1	
2	Z35G100101004T4	吸油法兰座 Flange	1	
3	Y18J100100008	转向泵吸油接头 Connector	1	

### Z38G1001013T2 盖板总成 Plate Assembly

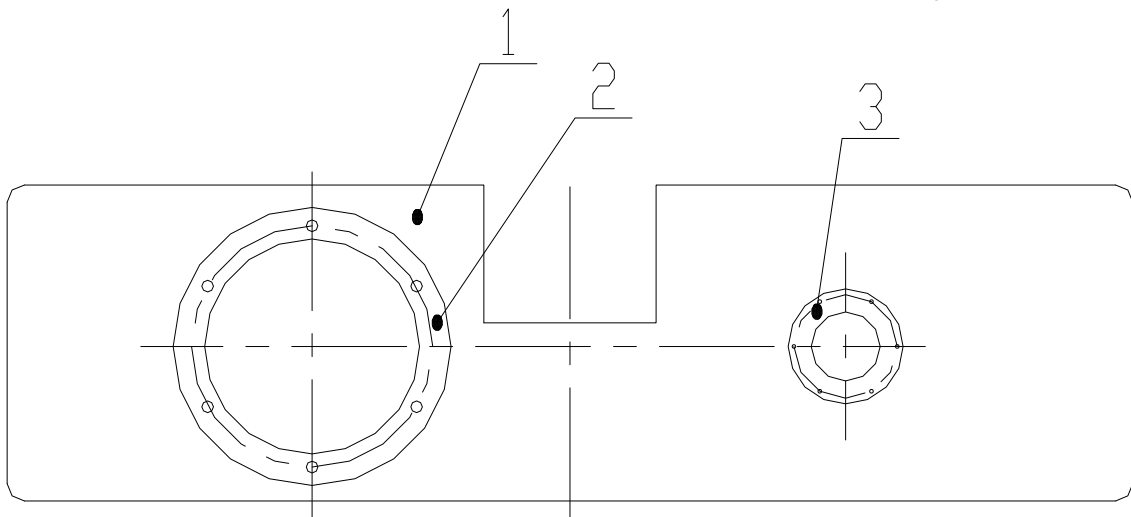

### Z38G1001013T2 盖板总成 Plate Assembly

序号 Item	代 号 Part No.	名 称 Parts Name	数量 Q'ty	备注 Remark
1	Z38G100101301T2	盖板 Plate	1	
2	Z35G100101002T4	法兰座 Flange	1	
3	Z35G100101005T4	空滤器座板 Plate	1	

### Z38G100102T2 机罩支撑板总成 Plate Assembly

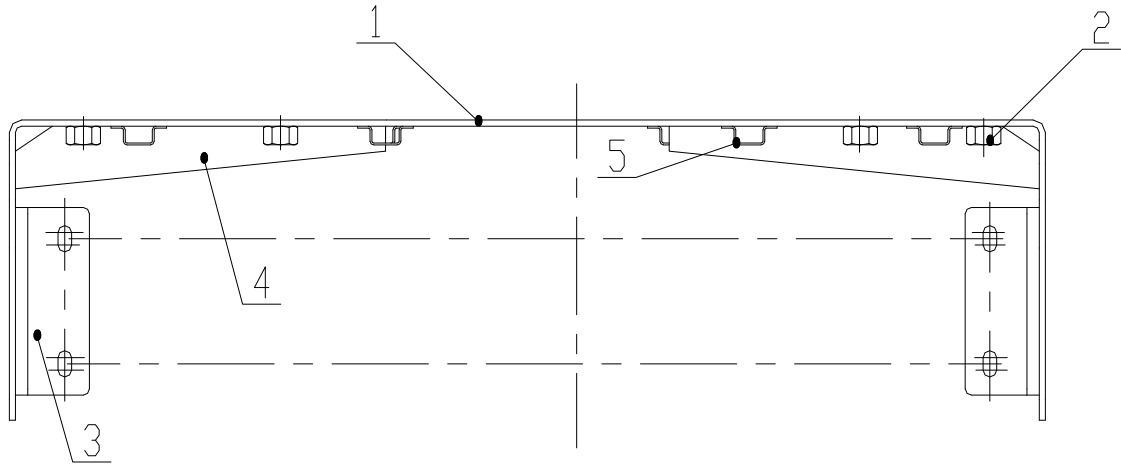

### Z38G100102T2 机罩支撑板总成 Plate Assembly

序号 Item	代 号 Part No.	名 称 Parts Name	数量 Q'ty	备注 Remark
1	Z38G100102001T2	U 形板 U Plate	1	
2	GB/T6170-2000	螺母 M16 Nut	4	
3	Z38G100104003	连接板 Plate	2	
4	Z38G100104002	加强板 Plate	2	
5	Z35G120901001T8	泡膜扣固定卡板 Plate	8	

### Z38G1015T1 箱端吸油总成 Steel Tube Assembly

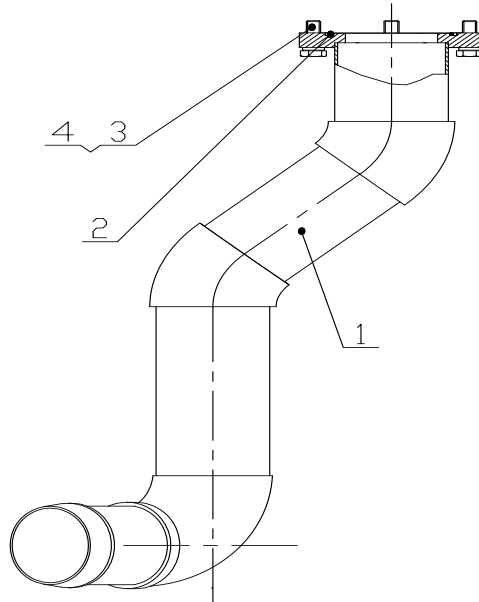

### Z38G1015T1 箱端吸油总成 Steel Tube Assembly

序号 Item	代 号 Part No.	名 称 Parts Name	数量 Q'ty	备注 Remark
1	Z38G101501T1	箱端吸油管 Steel Tube	1	
2	GB/T3452.1-1992	O 形圈 73X3.55 O Ring	1	
3	GB/T5783-2000	螺栓 M10X30 Bolt	4	
4	GB/T93-1987	垫圈 10 Washer	4	

## Z38G1002T2 回油管总成 Steel Tube Assembly

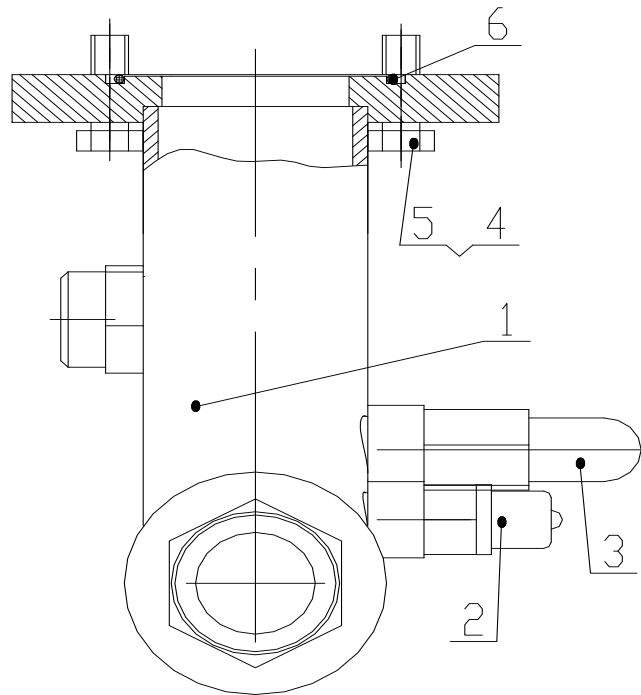

## Z38G1002T2 回油管总成 Steel Tube Assembly

序号 Item	代 号 Part No.	名 称 Parts Name	数量 Q'ty	备注 Remark
1	Z38G100201T2	回油管 Steel Tube	1	
2	PT-3-DKL	测压接头 Connector	1	
3	CY-II-0.35-M18X1.5	压差发讯器 Transmitter	4	
4	GB/T5783-2000	螺栓 M10X30 Bolt	4	
5	GB/T 93-1987	垫圈 10 Washer		
6	GB/T 3452.1-1992	O 形圈 73.5X3.55 O Ring		

## Z38G1004T1 稳定模块总成 Ride Control Valve Assembly

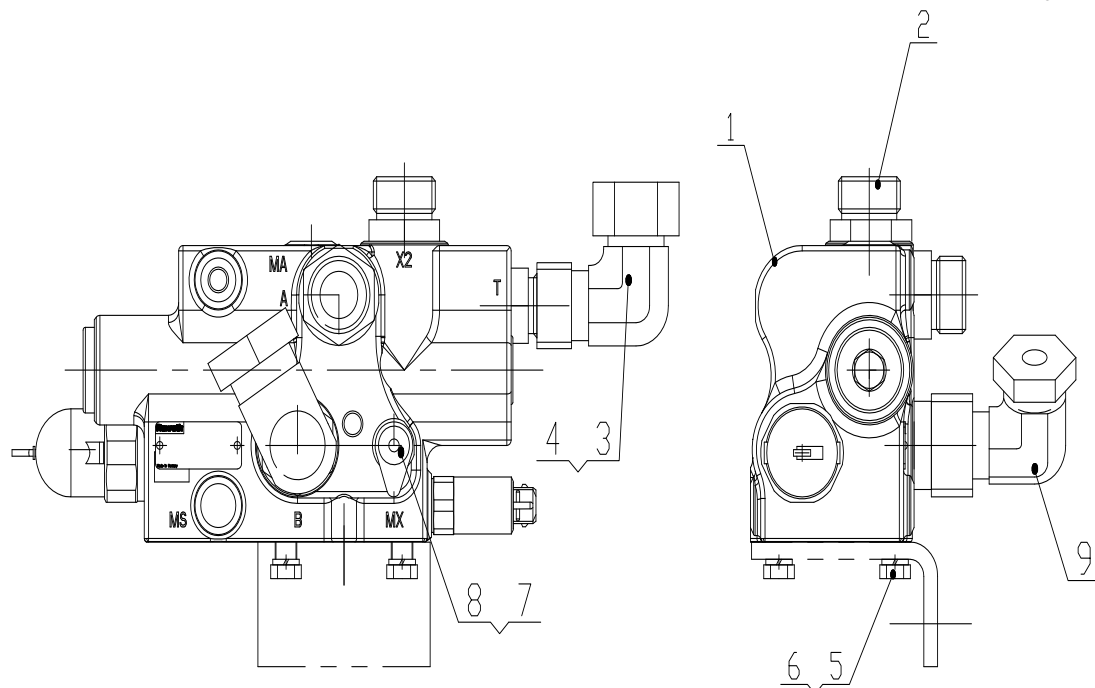

## Z38G1004T1 稳定模块总成 Ride Control Valve Assembly

序号	代 号	名 称		数量	备注
Item	Part No.	Parts Name		Q'ty	Remark
1	RSM2-16B2X/A250B12 0G24C4V01	稳定模块	Ride Control Valve	1	力士乐
2	1DG-36-16Z	接头体	Connector	3	
3	1CG-30-16Z	接头体	Connector	1	
4	2C9-30Z	接头	Connector	1	
5	GB/T5783-2000	螺栓 M10X30	Bolt	2	
6	GB/T93-1987	垫圈 10	Washer	2	
7	5GM-04-14Z	过渡接头	Connector	1	
8	PT-3-DKL	测压接头	Connector	1	
9	2D9-36Z	接头	Connector	1	



## Z38G1014T1 蓄能器总成 Accumulator Assembly

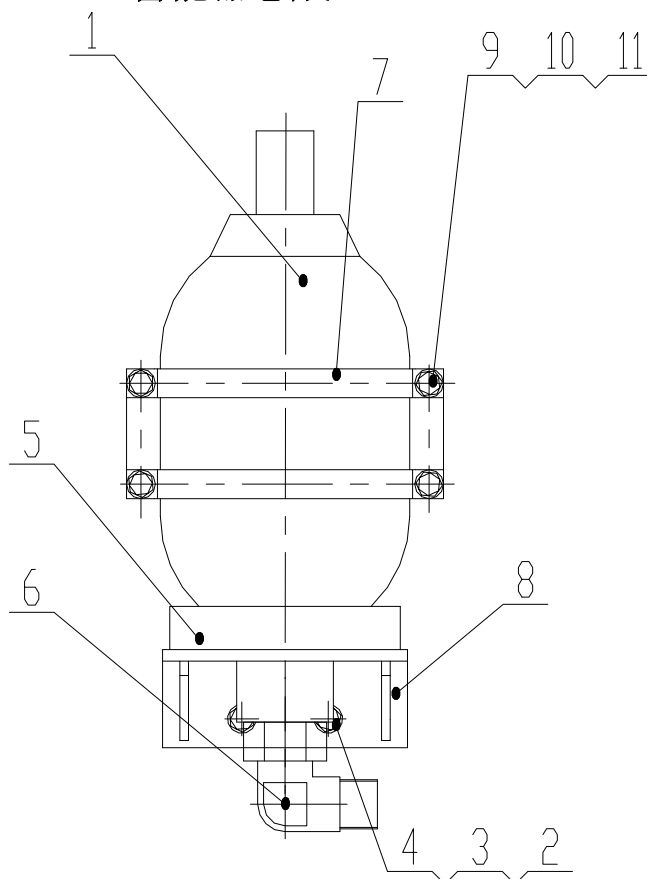

## Z38G1014T1 蓄能器总成 Accumulator Assembly

序号	代 号	名 称		数量	备注
Item	Part No.	Parts Name		Q'ty	Remark
1	SB330-4A1-112U9-33 0A	蓄能器	Accumulator	1	
2	GB/T97.2-2002	垫圈 10	Washer	2	
3	GB/T93-1987	垫圈 10	Washer	2	
4	GB/T5783-2000	螺栓 M10x25	Bolt	2	
5	Z50G090100001	橡胶垫	Cushion	1	
6	1DG9-36-200GZ	接头	Connector	1	
7	Z38G101400001T1	卡箍	Hoop	2	
8	Z38G101401T1	支架	Bracket	1	
9	GB/T97.2-2002	垫圈 8	Washer	4	
10	GB/T93-1987	垫圈 8	Washer	4	
11	GB/T5783-2000	螺栓 M8x25	Bolt	4	

## Z38G1003T1 多路阀总成 Multi-way valve Assembly

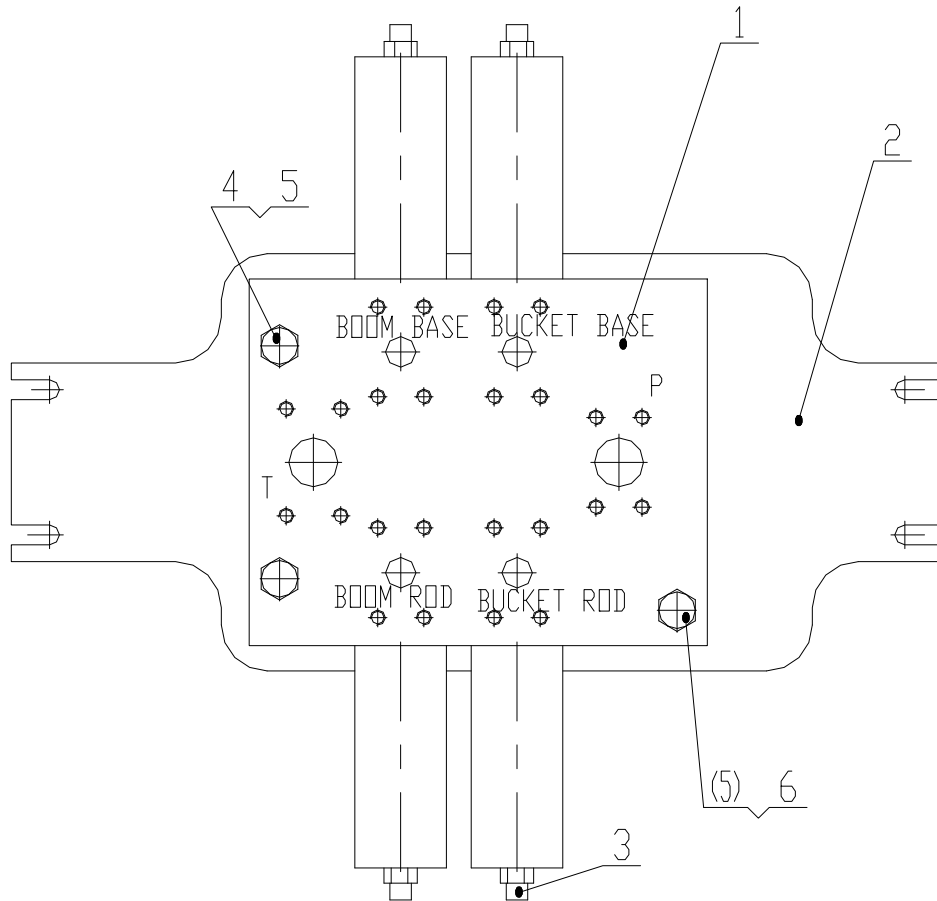

## Z38G1003T1 多路阀总成 Multi-way valve Assembly

序号	代 号	名 称		数量	备注
Item	Part No.	Parts Name		Q'ty	Remark
1	7130-B	多路阀	Multi-way valve	1	
2	Z38G100300001T1	多路阀支板	Plate	1	
3	1C0-16-06Z	接头体	Connector	4	
4	GB/T 5783-2000	螺栓 M16X110	Bolt	2	
5	GB/T 93-1987	垫圈 16	Washer	3	
6	GB/T 5783-2000	螺栓 M16X65	Bolt	1	

### Z38G1008T1 翻斗缸总成 Tilting Cylinder Assembly

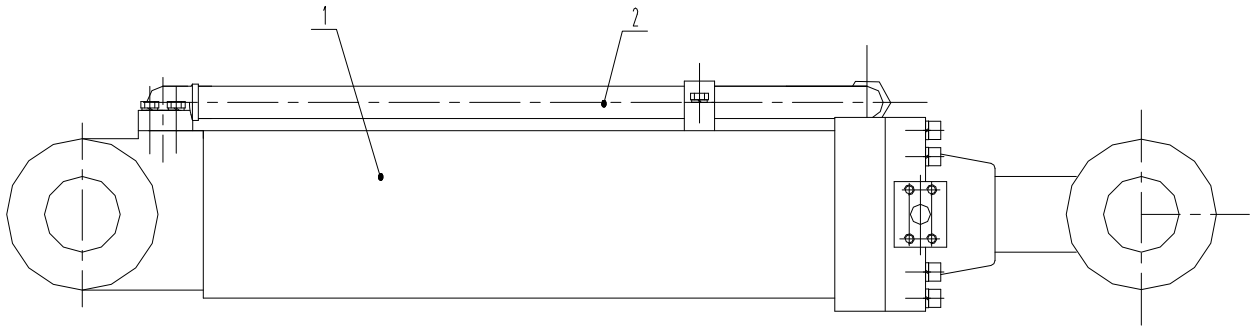

### Z38G1008T1 翻斗缸总成 Tilting Cylinder Assembly

序号 Item	代号 Part No.	名称 Parts Name		数量 Q'ty	备注 Remark
1	CG938HS-F. -00	翻斗缸	Tilting Cylinder	1	
2	Z38G100801T1	翻斗缸大腔硬管总成	Steel Tube Assembly	1	

### Z38G100801T1 翻斗缸大腔硬管总成 Assembly

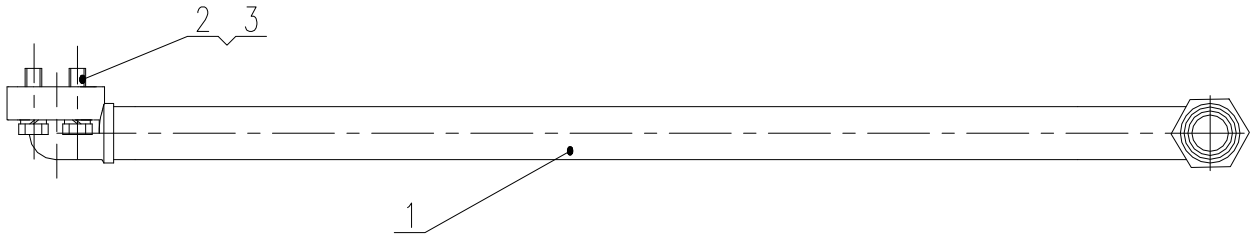

### Z38G100801T1 翻斗缸大腔硬管总成 Assembly

序号 Item	代号 Part No.	名称 Parts Name		数量 Q'ty	备注 Remark
1	Z38G1008011T1	翻斗缸大腔硬管	Pipe	1	
2	GB/T 5783-2000	螺栓M10X35	Bolt	4	
3	GB/T 93-1987	垫圈10	Washer	4	

### Z38G1006T1 左提升缸总成 Tilting Cylinder Assembly

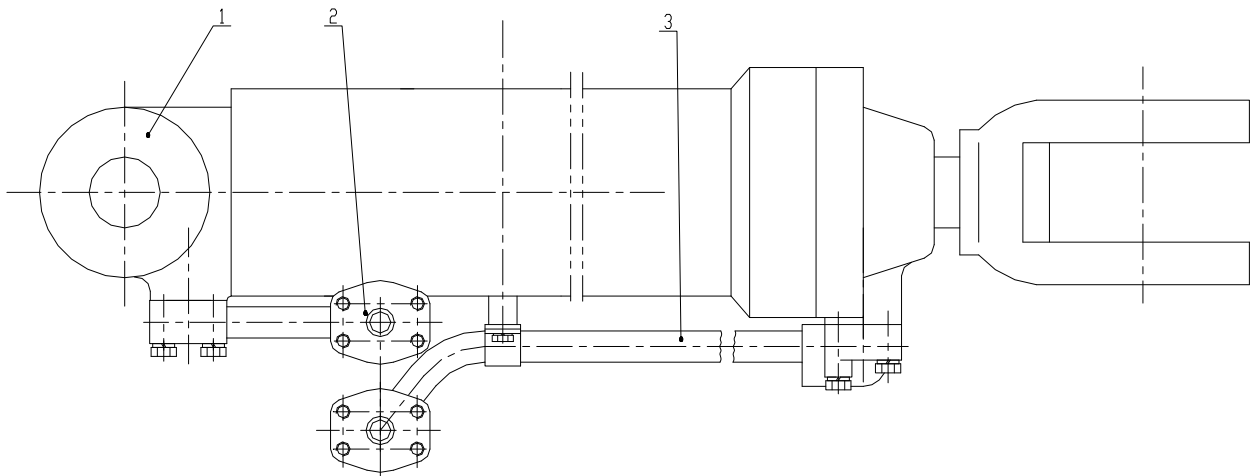

### Z38G1006T1 左提升缸总成 Tilting Cylinder Assembly

序号 Item	代号 Part No.	名 称 Parts Name		数量 Q'ty	备注 Remark
1	ZL38G120/70H.00	提升油缸	Tilting Cylinder	1	
2	Z38G100602T1	左提升缸大腔硬管总成	Steel Tube Assembly	1	
3	Z38G100601T1	左提升缸小腔硬管总成	Steel Tube Assembly	1	

### Z38G100601T1 左提升缸小腔硬管总成 Steel Tube Assembly

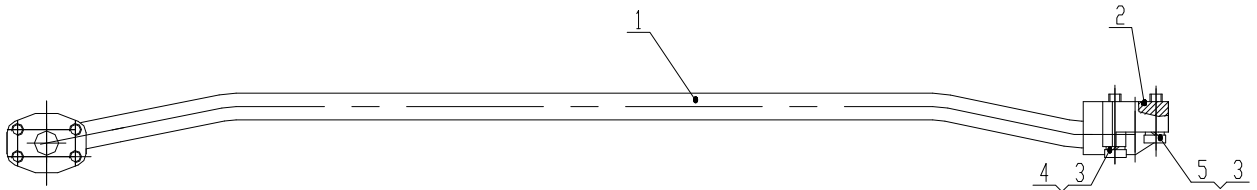

### Z38G100601T1 左提升缸小腔硬管总成 Steel Tube Assembly

序号 Item	代号 Part No.	名 称 Parts Name		数量 Q'ty	备注 Remark
1	Z38G1006011T1	左提升缸小腔硬管	Steel Tube	1	
2	GB/T3452.1-1992	O 形圈 28X3.55	O Ring	1	
3	GB/T93-1987	垫圈 10	Washer	4	
4	GB/T 70.1-2000	螺栓 M10X60	Bolt	2	
5	GB/T 70.1-2000	螺栓 M10X40	Bolt	2	

### Z38G100602T1 左提升缸大腔硬管总成 Steel Tube Assembly

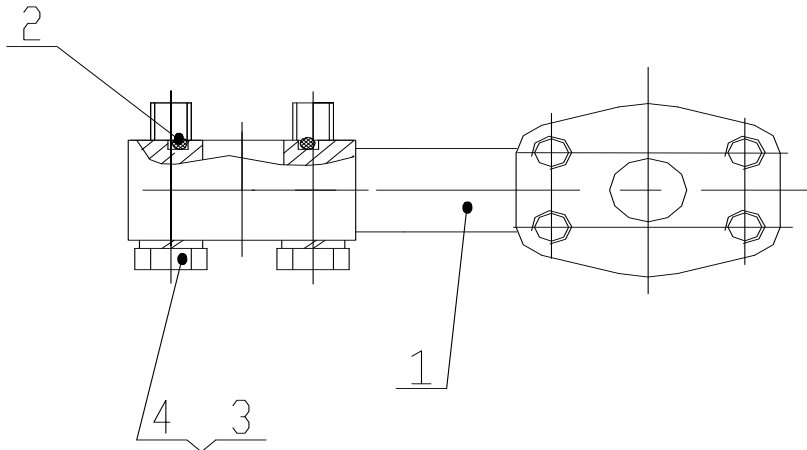

### Z38G100602T1 左提升缸大腔硬管总成 Steel Tube Assembly

序号 Item	代号 Part No.	名 称 Parts Name		数量 Q'ty	备注 Remark
1	Z38G1006021T1	左提升缸大腔硬管	Steel Tube	1	
2	GB/T3452.1-1992	O 形圈 28X3.55	O Ring	1	
3	GB/T5783-2000	螺栓 M10X60	Bolt	4	
4	GB/T93-1987	垫圈 10	Washer	4	

### Z38G1007T1 右提升缸总成 Tilting Cylinder Assembly

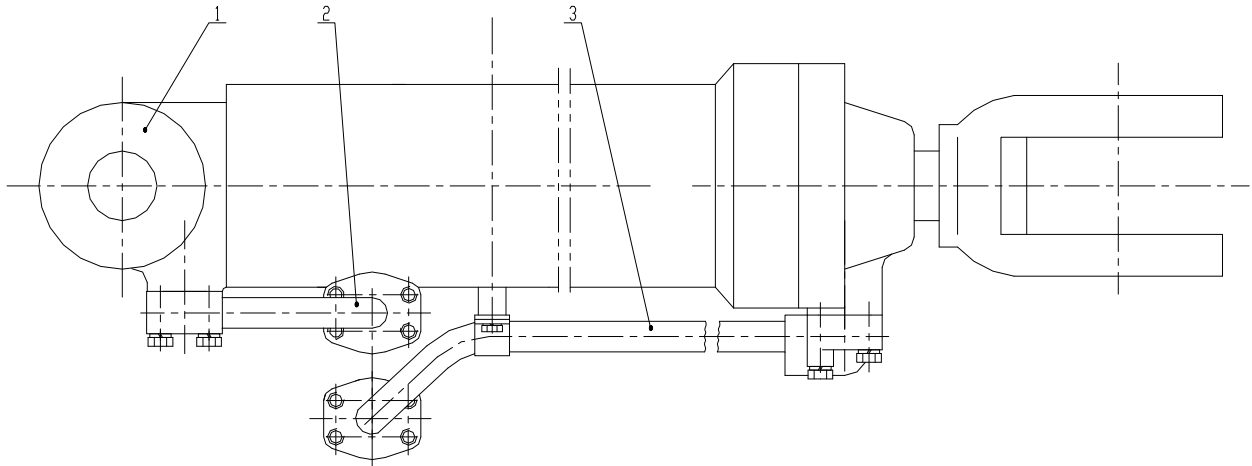

### Z38G1007T1 右提升缸总成 Tilting Cylinder Assembly

序号 Item	代号 Part No.	名 称 Parts Name	数量 Q'ty	备注 Remark
1	ZL38G120/70H.00	提升油缸 Tilting Cylinder	1	
2	Z38G100702T1	右提升缸大腔硬管总成 Steel Tube Assembly	1	
3	Z38G100701T1	右提升缸小腔硬管总成 Steel Tube Assembly	1	

### Z38G100702T1 右提升缸大腔硬管总成 Steel Tube Assembly

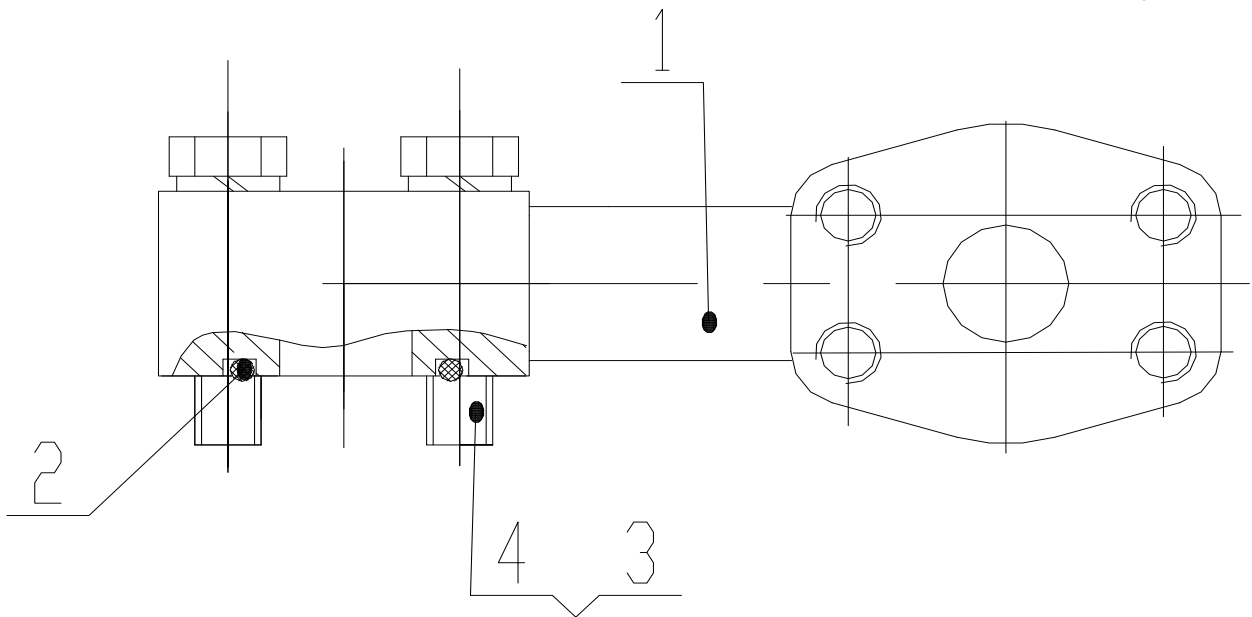

### Z38G100702T1 右提升缸大腔硬管总成 Steel Tube Assembly

序号 Item	代号 Part No.	名 称 Parts Name	数量 Q'ty	备注 Remark
1	Z38G1007021T1	右提升缸大腔硬管 Steel Tube	1	
2	GB/T3452.1-1992	O 形圈 28X3.55 O Ring	1	
3	GB/T5783-2000	螺栓 M10X60 Bolt	4	
4	GB/T93-1987	垫圈 10 Washer	4	

## Z38G100701T1 右提升缸小腔硬管总成 Steel Tube Assembly

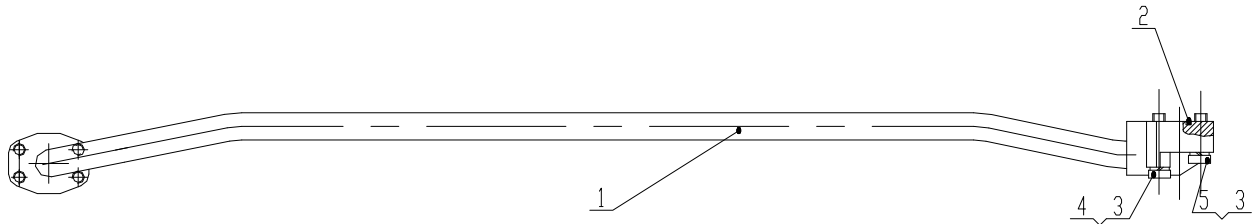

## Z38G100701T1 右提升缸小腔硬管总成 Steel Tube Assembly

序号 Item	代号 Part No.	名称 Parts Name		数量 Q'ty	备注 Remark
1	Z38G1007011T1	右提升缸小腔硬管	Steel Tube	1	
2	GB/T3452.1-1992	O形圈 28X3.55	O Ring	1	
3	GB/T93-1987	垫圈 10	Washer	4	
4	GB/T 70.1-2000	螺栓 M10X60	Bolt	2	
5	GB/T 70.1-2000	螺栓 M10X40	Bolt	2	

## Z38G1009T1 翻斗小腔硬管总成 Steel Tube Assembly

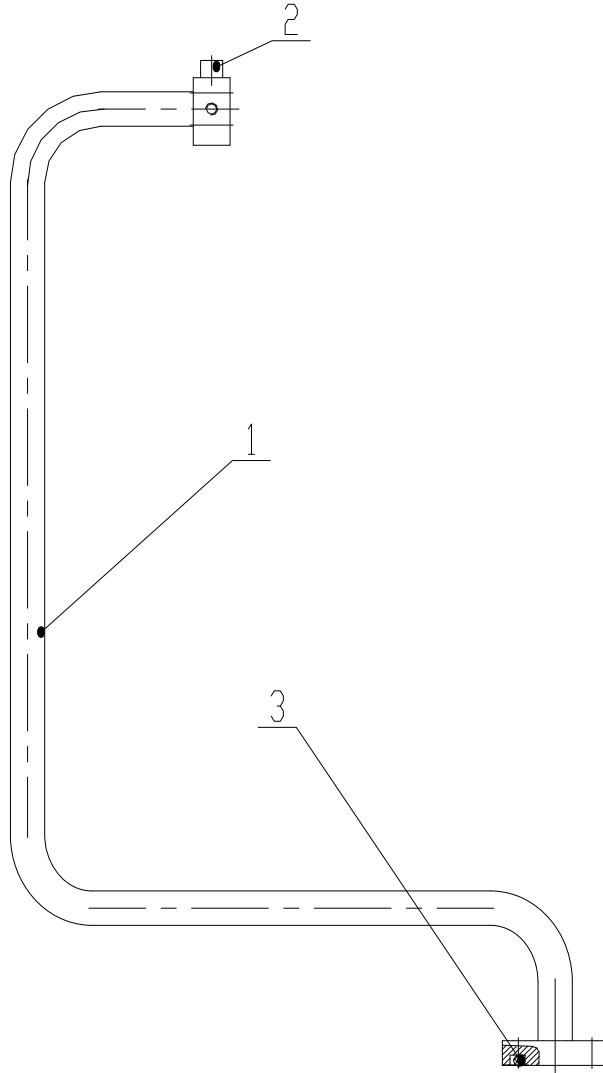

### Z38G1009T1 翻斗小腔硬管总成 Steel Tube Assembly

序号 Item	代号 Part No.	名 称 Parts Name	数量 Q'ty	备注 Remark
1	Z38G100901T1	翻斗小腔硬管 Steel Tube	1	
2	4M-14WDZ	堵头 Plug	1	
3	GB/T 3452.1-1992	O 形圈 37.5X3.55 O Ring	1	

### Z38G1010T1 动臂小腔硬管总成 Steel Tube Assembly

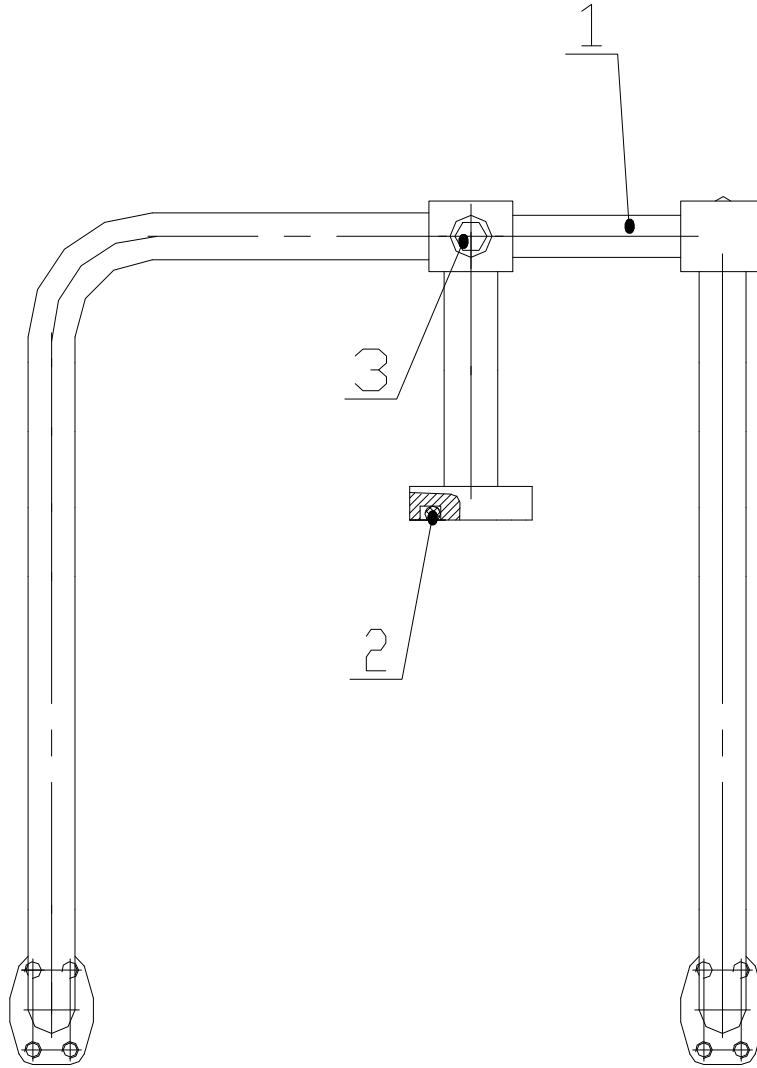

### Z38G1010T1 动臂小腔硬管总成 Steel Tube Assembly

序号 Item	代号 Part No.	名 称 Parts Name	数量 Q'ty	备注 Remark
1	Z38G101001T1	动臂小腔硬管 Steel Tube	1	
2	GB/T 3452.1-1992	O 形圈 37.5X3.55 O Ring	1	
3	4M-14WDZ	堵头 Plug	1	

## Z38G1011T1 动臂大腔硬管总成 Steel Tube Assembly

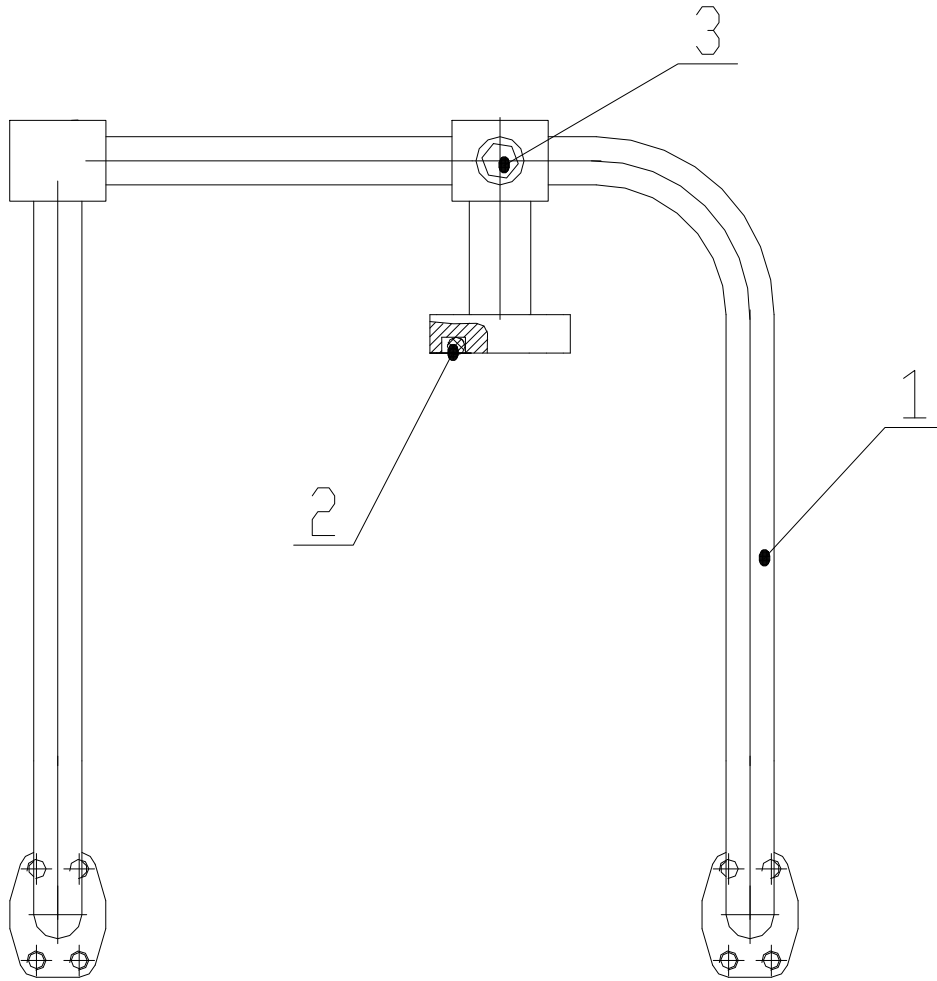

## Z38G1011T1 动臂大腔硬管总成 Steel Tube Assembly

序号 Item	代号 Part No.	名 称 Parts Name	数量 Q'ty	备注 Remark
1	Z38G101101T1	动臂大腔硬管 Steel Tube	1	
2	GB/T 3452.1-1992	O 形圈 37.5X3.55 O Ring	1	
3	4M-14WDZ	堵头 Plug	1	



## Z38G1012T1 翻斗大腔硬管总成 Steel Tube Assembly

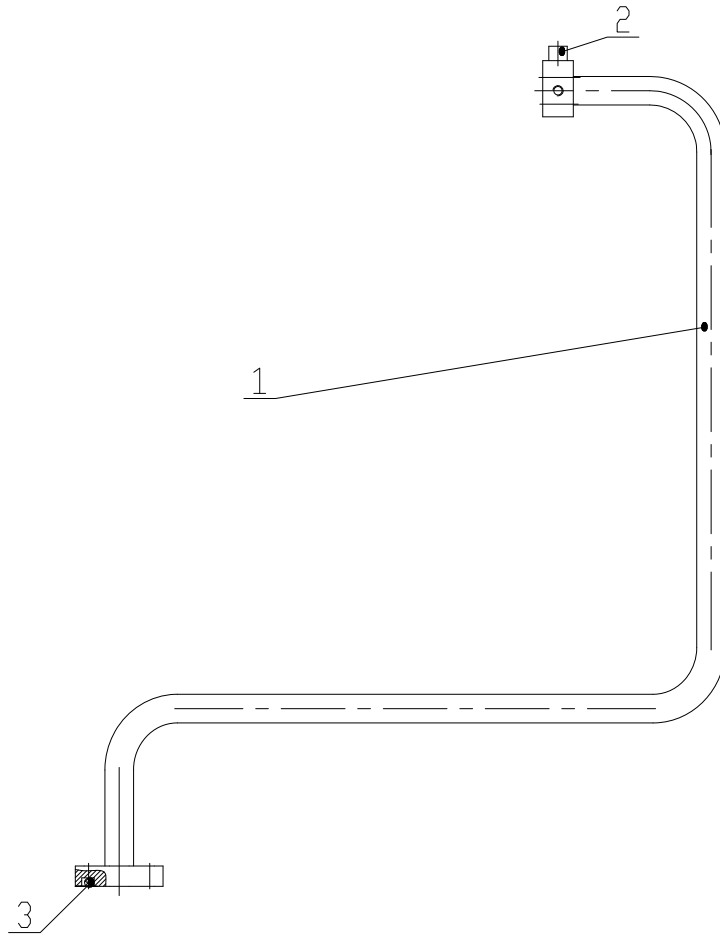

## Z38G1012T1 翻斗大腔硬管总成 Steel Tube Assembly

序号 Item	代号 Part No.	名 称 Parts Name	数量 Q'ty	备注 Remark
1	Z38G101201T1	翻斗大腔硬管 Steel Tube	1	
2	4M-14WDZ	堵头 Plug	1	
3	GB/T 3452.1-1992	O 形圈 37.5X3.55 O Ring	1	

## Z38G1013T1 多路阀 T 口总成 Multi-way Valve T Meatus Assembly

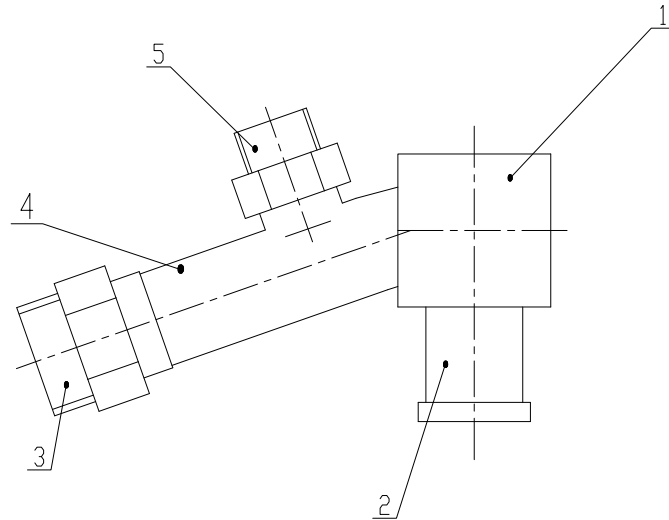

## Z38G1013T1 多路阀 T 口总成 Multi-way Valve T Meatus Assembly

序号 Item	代号 Part No.	名 称 Parts Name		数量 Q'ty	备注 Remark
1	Z38G101300001T1	接头体	Connector	1	
2	1FLW-24-38X4.0	焊管	Tube	1	
3	1CW-45-35	接头体	Connector	1	
4	Z38G101300002T1	弯管	Tube	1	
5	1CW-30-22	接头体	Connector	1	

## Z38G1005T2 先导系统总成 Pilot Hydraulic System

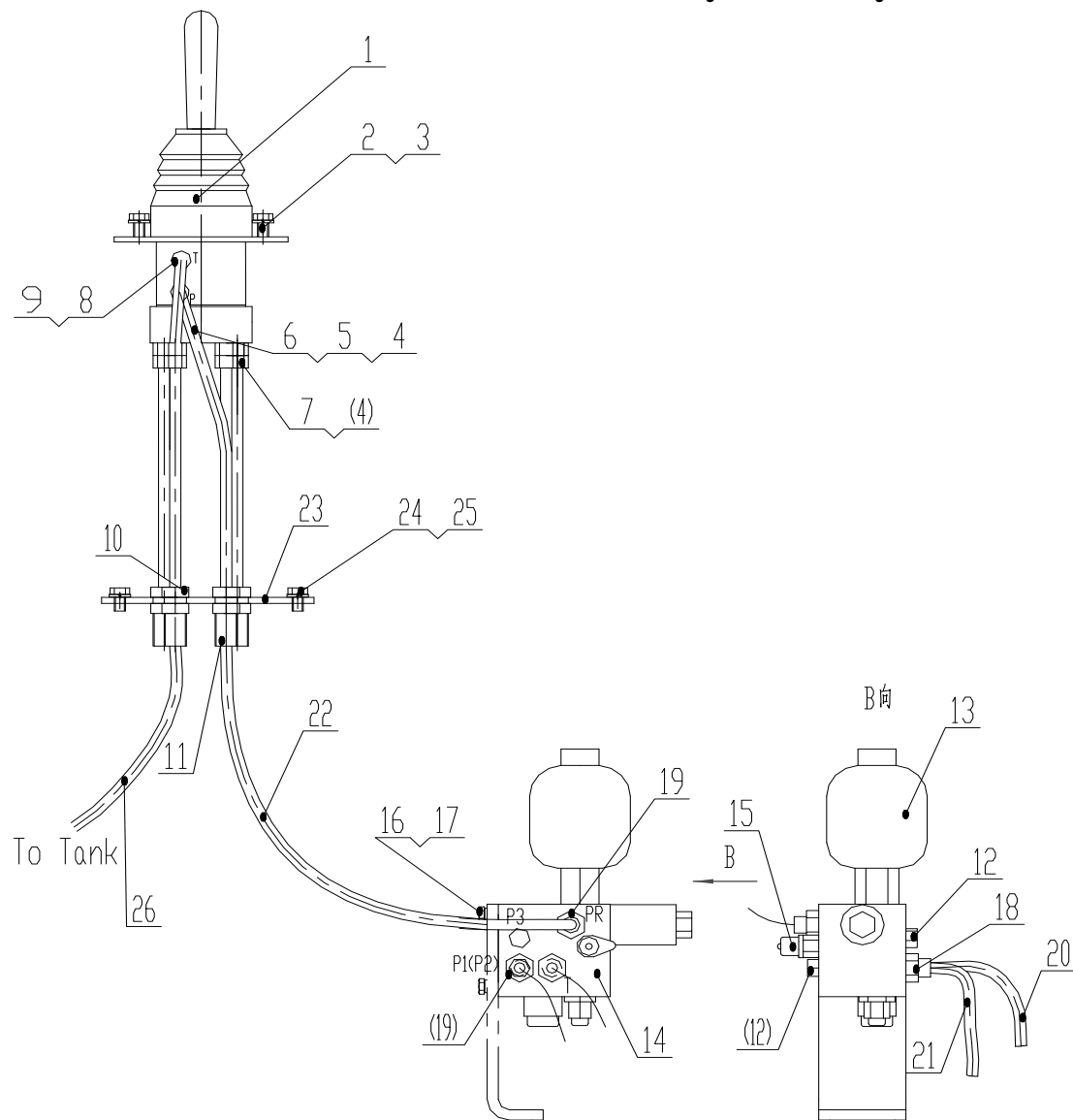

## Z38G1005T2 先导系统总成 Pilot Hydraulic System

序号 Item	代号 Part No.	名 Parts	称 Name	数量 Q'ty	备注 Remark
1	406-1044-1145	先导阀	Pilot Valve	1	
2	GB/T93-1987	垫圈 6	Washer 6	4	
3	GB/T5783-2000	螺栓 M6X20	Bolt M6x20	4	
4	1CM-16-14WDZ	接头	Connector	5	
5	2C9-16Z	接头	Connector	1	
6	20411-16-04ZX1T04X570	胶管	Hose	1	
7	20411-16-04ZX1T04X570	胶管	Hose	4	
8	1CM-18-14WDZ	接头	Connector	1	
9	20491-18-06Z/20411-18-06ZX1T06X610	胶管	Hose	1	
10	6C-18-LNZ	接头	Connector	1	
11	6C-16-LNZ	接头	Connector	5	
12	4M-14WDZ	堵头	Plug	2	
13	SB0210-0.32E1/112U-210AK60	蓄能器	Accumulator	1	
14	DKF1-00	先导供油阀	Valve	1	
15	PT-3-DKL	测压接头	Connector	1	
16	GB/T93-1987	垫圈 8	Washer	2	
17	GB/T5783-2000	螺栓 M8X25	Bolt	2	
18	1CM-18-14WDZ	接头	Connector	1	
19	1CM-16-14WDZ	接头	Connector	2	
20	20491-16-04ZX1T04X1130V90	胶管	Hose	1	
21	20441-18-05Z/20411-18-05ZTX1T05X290	胶管	Hose	1	
22	20491-16-04Z/20411-16-04ZX1T04ITX1150	胶管	Hose	1	
23	Z38G100500001T1	连接板	Plate	1	
24	GB/T 5783-2000	螺栓 M8X16	Bolt	4	
25	GB/T 93-1987	垫圈 8	Washer	4	
26	20411-18-06ZX1T06X1300	胶管	Hose	1	

## Z38G1006T2 稳定模块总成 Ride Control Valve Assembly

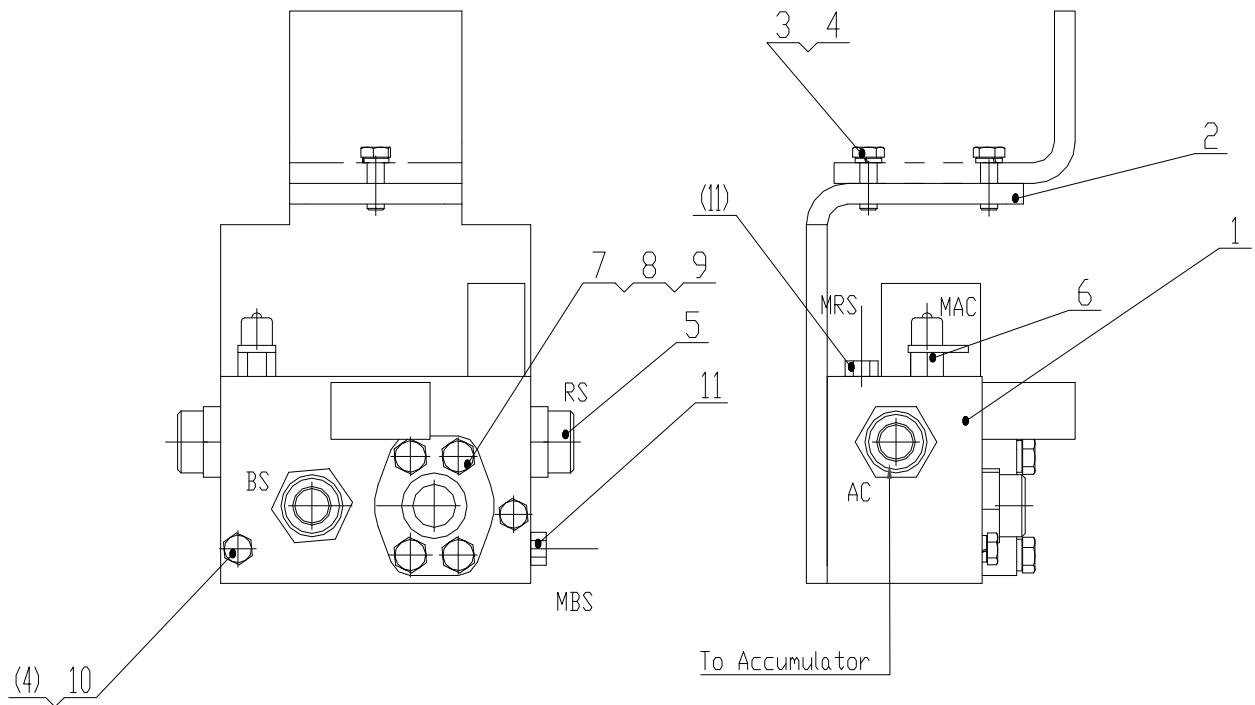

## Z38G1006T2 稳定模块总成 Ride Control Valve Assembly

序号 Item	代号 Part No.	名 Parts	称 Name	数量 Q'ty	备注 Remark
1	PHGZ-PU-06027-B0-0-TJ	稳定模块	Ride Control Valve	1	
2	Z38G100600001T2	过渡板	Plate	1	
3	GB/T 5783-2000	螺栓 M10X30	Bolt	2	
4	GB/T 93-1987	垫圈 10	Washer	4	
5	1DH-36-33Z	接头体	Connector	3	
6	PT-3-DKL	测压接头	Connector	1	
7	FS-16Z	对开法兰夹	Flange	1	
8	GB/T 5783-2000	螺栓 M12X45	Bolt	4	
9	GB/T 93-1987	垫圈 12	Washer	4	
10	GB/T 5782-2000	螺栓 M10X110	Bolt	2	
11	4M-14WDZ	堵头	Plug	2	

后传动轴  
**Rear Driving Shaft**

## Z35C11 后传动轴 Rear Drive Shaft

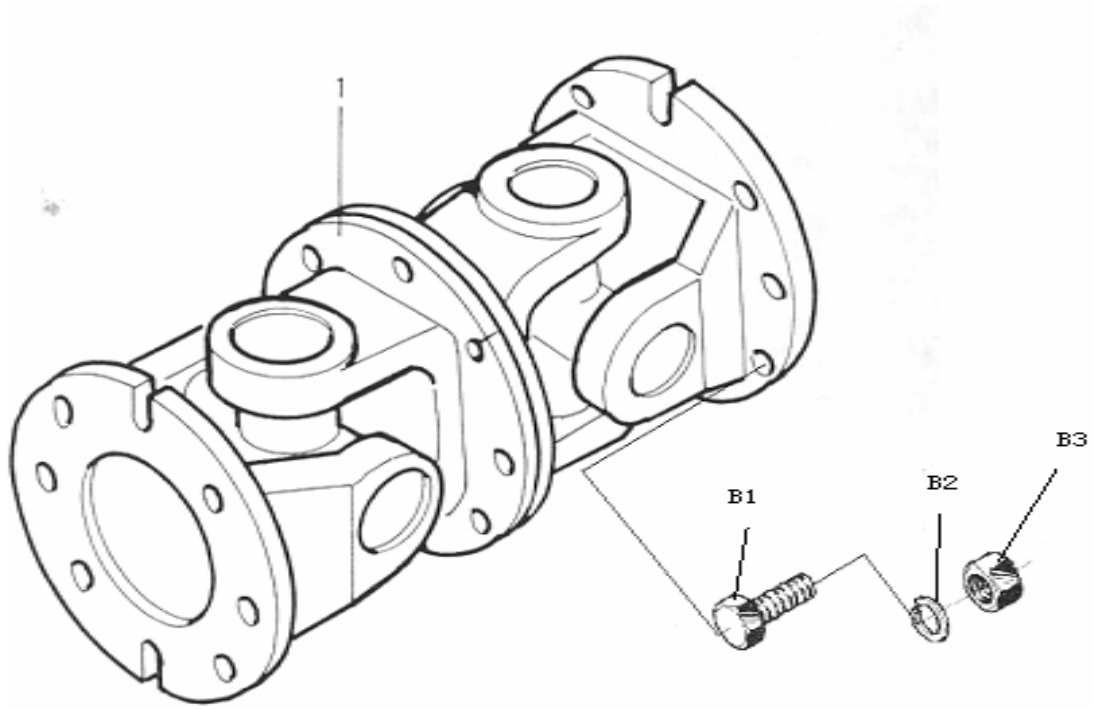

## Z35C11 后传动轴 Rear Drive Shaft

序号 Item	代号 Part No.	名 称 Parts Name		数量 Q'ty	备注 Remark
1	Z35C11	后传动轴总成	Rear Drive Shaft	1	
B1	GB5783-2000	螺栓M12X40	Bolt M12X40	8	
B3	GB889.1-2000	螺母M12	Nut M12	16	



车身车架  
**Frame Group**

# Z38G12T2 车身车架 (一) Frame Group (I)

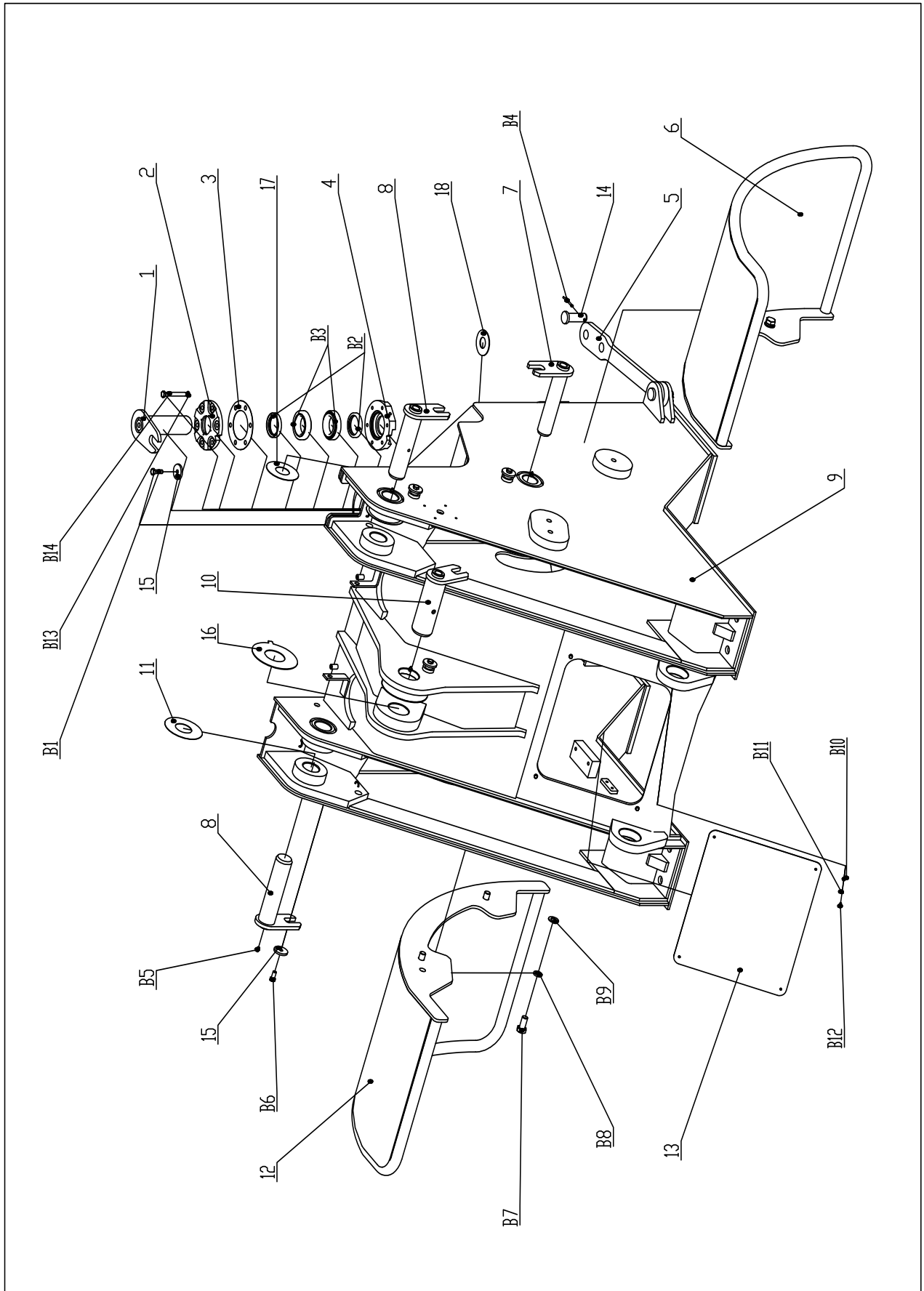

## Z38G12T2 车身车架（一） Frame Group( I )

序号 Item	代 号 Part No.	名 称 Parts Name	数量 Q'ty	备注 Remark
1	Z301213	上铰接销轴总成 Pin Shaft	1	
2	Z3012000009	上铰接轴承上盖 Bearing Cover	1	
3	Z3012000010	调整垫片 Adjusting Shim	1组	
4	Z3012000011	上铰接轴承下盖 Lower Bearing Cover	1	
5	Z3012000002	支撑杆 Support Rod	1	
6	Z38G1202T1	左前护泥板总成 Left Front Fender Assembly	1	
7	Z301205	提升油缸销轴总成 Pin Shaft	2	
8	Z301206	动臂销轴总成 Pin Shaft	2	
9	Z38G1201T1	前车架总成 Front Frame Assembly	1	
10	Z301204	翻斗油缸销轴总成 Pin Shaft	1	
11	Z3012000004	调整垫片 Adjusting Shim	1组	
12	Z38G1203T1	右前护泥板总成 Right Front Fender Assembly	1	
13	Z3012000005	前封板 Front Seal Plate	1	
14	Z3012000001	插销 Pin	2	
15	Z35H12000001	垫圈 Washer	5	
16	Z3012000024	垫片 Shim	1组	
17	Z3012000007	调整垫片 Adjusting Shim	1组	
18	Z3012000006	调整垫片 Adjusting Shim	4组	
B1	GB/T5783-2000	螺栓M12X35 Bolt M12X35	1	
B2	HG4-692-67	油封PD60X80X12 Oil Seal PD60X80X12	2	
B3	GB/T297-94	轴承32012 Bearing 32012	2	
B4	GB/T91-2000	销4.5X45 Pin 4.5X45	2	
B5	JB/T7940.1-95	油杯M10X1 Oil Cup M10X1	7	
B6	GB/T5783-2000	螺栓M12X25 Bolt M12X25	5	
B7	GB/T5783-2000	螺栓M20X40 Bolt M20X40	6	
B8	GB/T93-87	垫圈20 Washer 20	6	
B9	GB/T97.1-2002	垫圈20 Washer 20	6	
B10	GB/T97.1-2000	垫圈6 Washer 6	4	
B11	GB/T93-87	垫圈6 Washer 6	4	
B12	GB/T5783-2000	螺栓M6X16 Bolt M6X16	4	
B13	GB/T93-87	垫圈12 Washer 12	19	
B14	GB/T5782-2000	螺栓M12X85 Bolt M12X85	6	

## Z38G12T2 车身车架 (二) Frame Group(II)

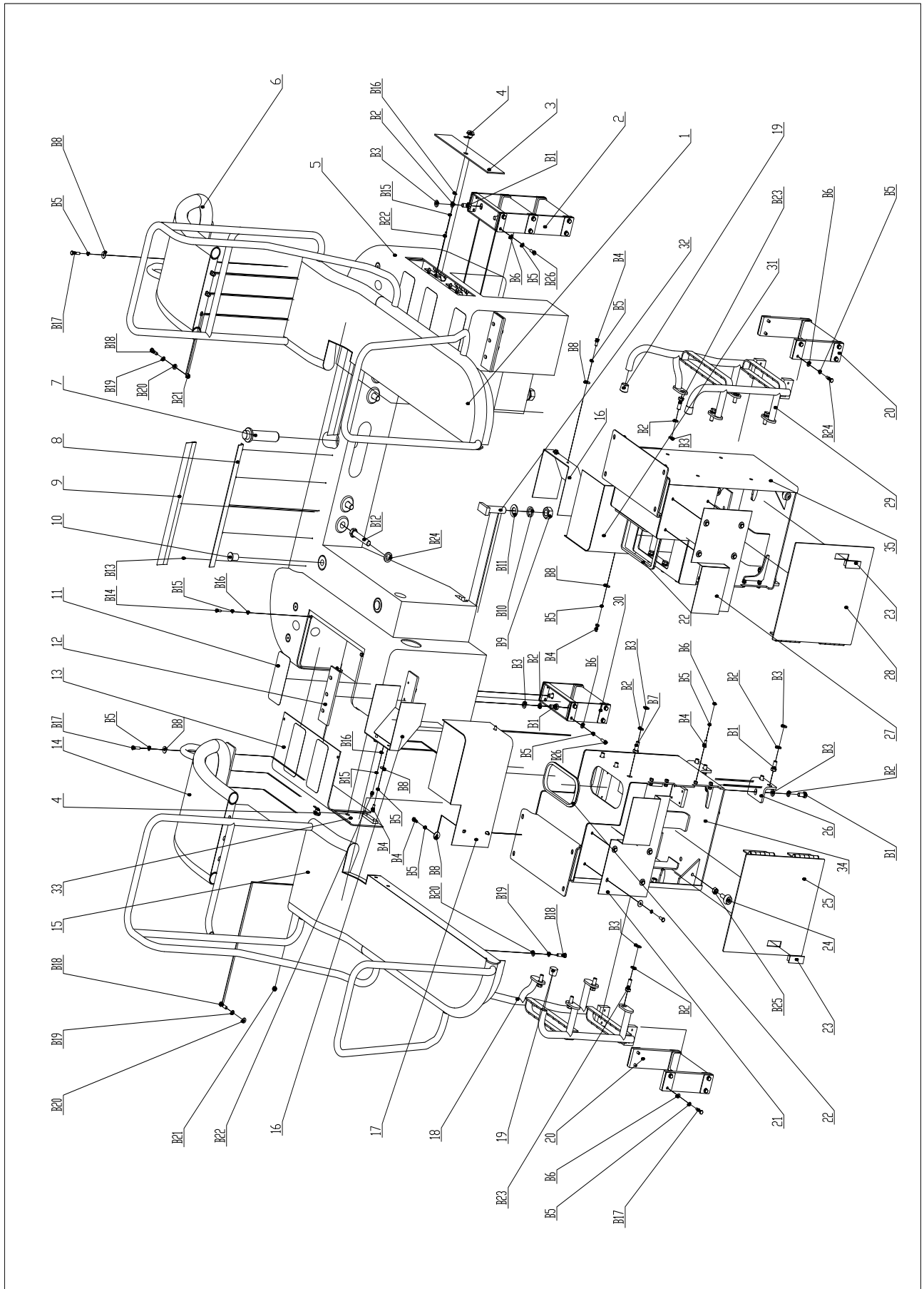

## Z38G12T2 车身车架（二） Frame Group(II)

序号 Item	代 号 Part No.	名 称 Parts Name		数量 Q'ty	备注 Remark
1	Z38G120401T1	左后护泥	Left Rear Fender	1	
2	Z50G121102T15	配重脚踏	Ladder Of Ballast	1	
3	Z38G121103T2	电源开关箱门体	Door Of Left Box	1	
4	GMS506	锁	Lock	2	
5	Z38G121101T2	配重焊接体	Ballast	1	
6	Z38G120402T1	左后护泥支撑	Brace Of Left Rear Fender	1	
7	Z38G12000009T1	牵引销	Pin	1	
8	Z38G121100005T1	胶条安装L型板	Fixing Plate Of Rubber Strip	2	
9	Z38G121100007T1	配重胶条	Rubber Strip	2	
10	Z50E120000002T15	橡胶螺塞	Rubber Plug	3	
11	YN20T01282P1	防滑垫	Skidproof Cushion	6	
12	Z38G120000002T2	后护泥支撑胶皮	Rubber Cushion	2	
13	Z38G121100001T2	电瓶箱封板	Right Close Plate	1	
14	Z38G120502T1	右后护泥支撑	Brace Of Right Rear Fender	1	
15	Z38G120501T1	右后护泥	Right Rear Fender	1	
16	Z38G1215T1	角封板总成	Back Decorative Plate	2	
17	Z38G1221T1	右侧中围板	Right Middle Decorative Plate	1	
18	Z38G121901T2	扶梯支架	Right Staircase	1	
19	Z50G121800001T15	橡胶套	Rubber Sheath	4	
20	Z301211	脚踏板	Ladder	2	
21	Z38G1220T1	右侧前围板	Right Front Decorative Plate	1	
22	Z38G121600002T1	胶条	Rubber Strip	2	
23	MS606-1-2	锁	Lock	2	
24	Z50G120900004T15	橡胶块	Shock Absorber	4	
25	Z38G121602T2	门板体	Door Of Right Installation Box	1	
26	Z50G121600002T17	支撑板	Plate Of underprop	4	
27	Z38G1213T1	左侧前围板	Left Front Decorative Plate	1	
28	Z38G121702T2	门板体	Door Of Left Installation Box	1	
29	Z38G121801T2	扶梯支架	Left Staircase	1	
30	Z50G121101T15	配重脚踏	Ladder Of Ballast	1	
31	Z38G1214T1	左侧中围板	Left Middle Decorative Plate	1	
32	Z50G120000002T17	自制配重螺栓	Bolt Of Ballast	2	
33	Z38G121102T2	加油箱门体	Door Of Right Box		

## Z38G12T2 车身车架 (二) Frame Group(II)

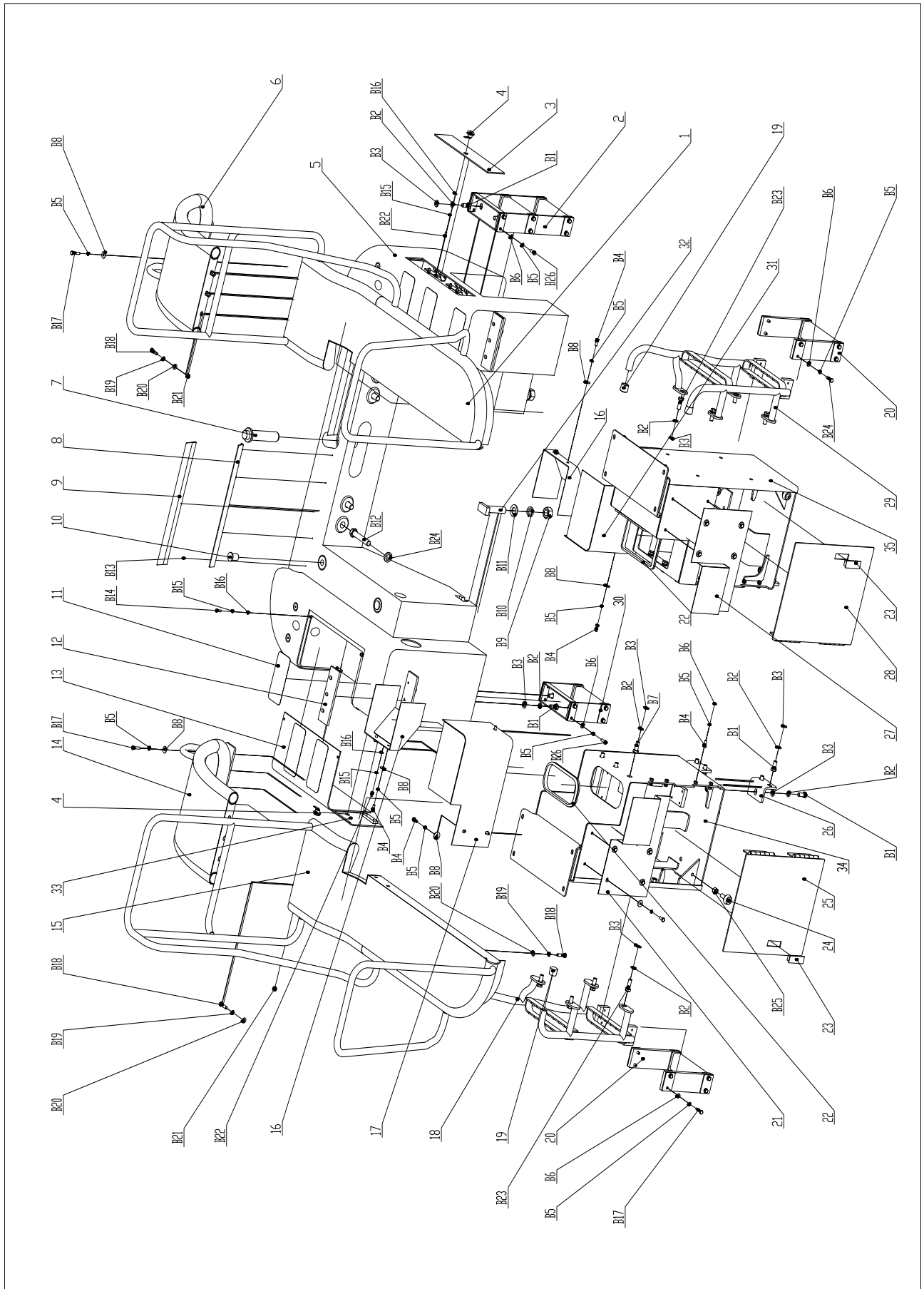

## Z38G12T2 车身车架（二） Frame Group(II)

序号 Item	代 号 Part No.	名 称 Parts Name		数量 Q'ty	备注 Remark
34	Z38G121601T2	右安装箱体	Right Installation Box	1	
35	Z38G121701T2	左安装箱体	Left Installation Box	1	
B1	GB/T5783-2000	螺栓M16X35	Bolt M16X35	12	
B2	GB/T93-87	垫圈16	Washer 16	26	
B3	GB/T97.1-2002	垫圈16	Washer 16	26	
B4	GB/T5783-2000	螺栓M10X25	Bolt M10X25	18	
B5	GB/T93-87	垫圈10	Washer 10	44	
B6	GB/T97.1-2002	垫圈10	Washer 10	34	
B7	GB/T5783-2000	螺栓M16X40	Bolt M16X40	6	
B8	GB/T96.1-2002	垫圈10	Washer 10	10	
B9	GB/T6170-2000	螺母M30	Nut M30	2	
B10	GB/T93-87	垫圈30	Washer 30	2	
B11	GB/T97.1-2002	垫圈30	Washer 30	2	
B12	GB/T5783-2000	螺栓M24X130	Bolt M24X130	4	
B13	GB/T819.2	螺钉M5X16	Bolt M5X16	10	
B14	GB/T5783-2000	螺栓M8X25	Bolt M8X25	4	
B15	GB/T93-87	垫圈8	Washer 8	10	
B16	GB/T97.1-2002	垫圈8	Washer 8	10	
B17	GB/T5783-2000	螺栓M10X40	Bolt M10X40	6	
B18	GB/T5783-2000	螺栓M12X45	Bolt M12X45	14	
B19	GB/T93-87	垫圈12	Washer 12	14	
B20	GB/T97.1-2002	垫圈12	Washer 12	14	
B21	GB/T6170-2000	螺母M12	Nut M12	6	
B22	GB/T5783-2000	螺栓M8X16	Bolt M8X16	6	
B23	GB/T5783-2000	螺栓M16X45	Bolt M16X45	8	
B24	GB/T93-87	垫圈24	Washer 24	4	
B25	GB/T6170-2000	螺母M16	Nut M16	2	
B26	GB/T5783-2000	螺栓M10X30	Bolt M10X30	20	

# Z38G12T2 车身车架 (三) Frame Group III

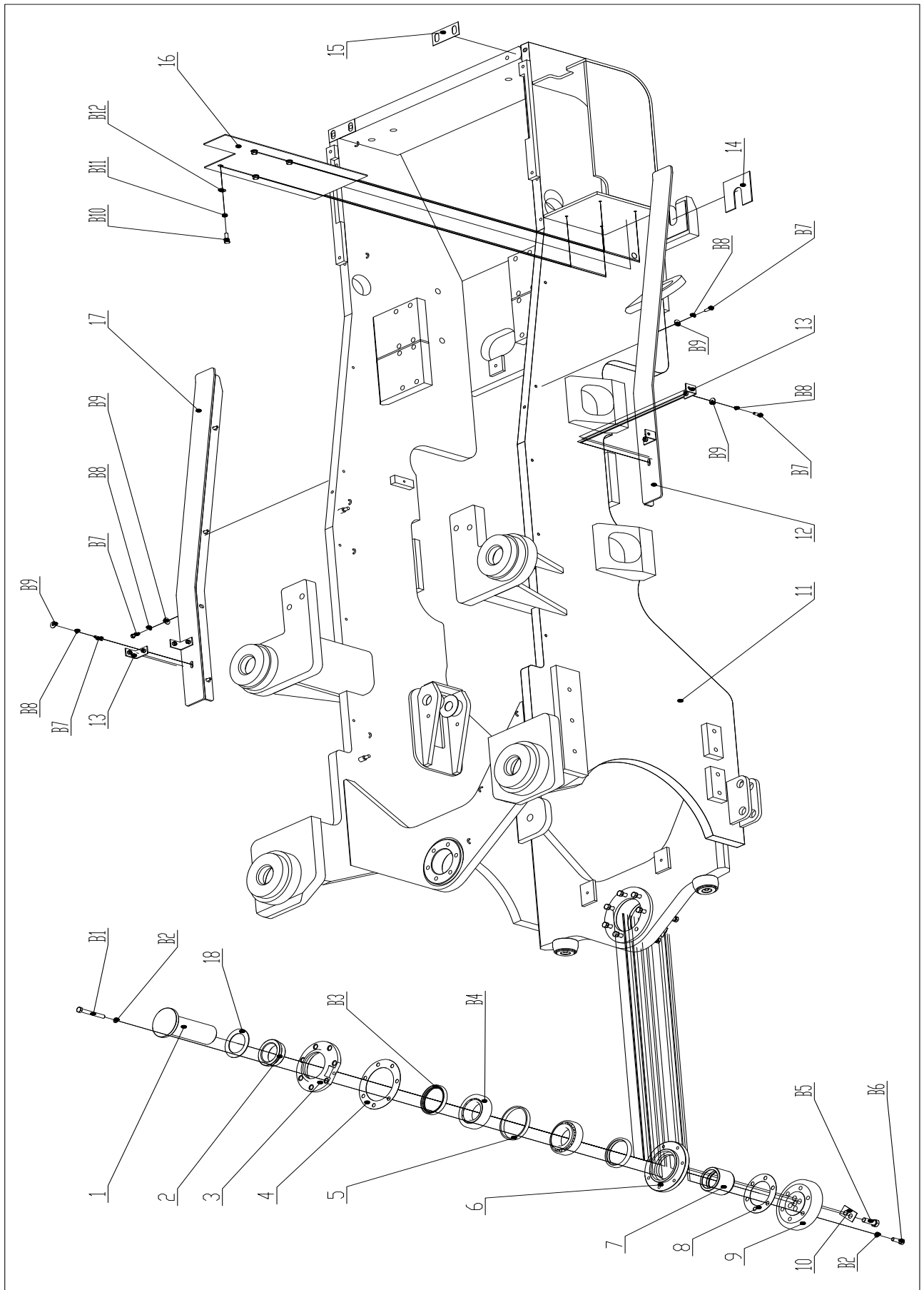



### Z38G12T2 车身车架（三） Frame Group(III)

序号 Item	代 号 Part No.	名 称 Parts Name		数量 Q'ty	备注 Remark
1	Z30120000012	下铰接销轴	Pin Shaft	1	
2	Z30120000013	挡环	Snap Ring	1	
3	Z30120000014	下铰接轴承上盖	Bearing Cover	1	
4	Z30120000015	上调整垫片	Shim	1组	
5	Z30120000016	挡环	Snap Ring	1	
6	Z30120000017	下铰接轴承下盖	Bearing Cover	1	
7	Z30120000018	挡环	Snap Ring	1	
8	Z30120000021	调整垫片	Shim	1组	
9	Z30120000019	孔板	Hole Plate	1	
10	Z30120000020	止动垫圈	Washer	2	
11	Z38G1210T2	后车架总成	Rear Frame Assembly	1	
12	Z38G122001T2	机罩左封板体	Left Hood Surrounding Plate	1	
13	Z38G122002T2	安装支架题	Bracket	4	
14	Z50G120000008T15	配重调整垫片	Adjust Shim	2组	
15	Z38G120000001T2	机罩调整垫片	Adjust Shim	2组	
16	Z38G120000008T1	机罩推杆箱封板	Close Plate	1	
17	Z38G122101T2	机罩右封板体	Right Hood Surrounding Plate	1	
18	Z40F120000001T2	调整垫片	Adjust Shim	1	
B1	GB/T5782-2000	螺栓M12X100	Bolt M12X100	7	
B2	GB/T93-87	垫圈12	Washer 12	13	
B3	HG4-692-67	油封PD90X110X12	Oil Seal PD90X110X12	2	
B4	GB/T297-94	轴承32214	Bearing 32214	2	
B5	GB/T5783-2000	螺栓M16X45	Bolt M16X45	4	
B6	GB/T5783-2000	螺栓M12X35	Bolt M12X35	6	
B7	GB/T5783-2000	螺栓M8X25	Bolt M8X25	12	
B8	GB/T93-87	垫圈8	Washer 8	12	
B9	GB/T96.1-2002	垫圈8	Washer 8	12	
B10	GB/T5783-2000	螺栓M10X30	Bolt M10X30	12	
B11	GB/T93-87	垫圈10	Washer 10	12	
B12	GB/T97.1-2002	垫圈10	Washer 10	12	

# Z38G12T2 车身车架 (四) Frame Group (IV)

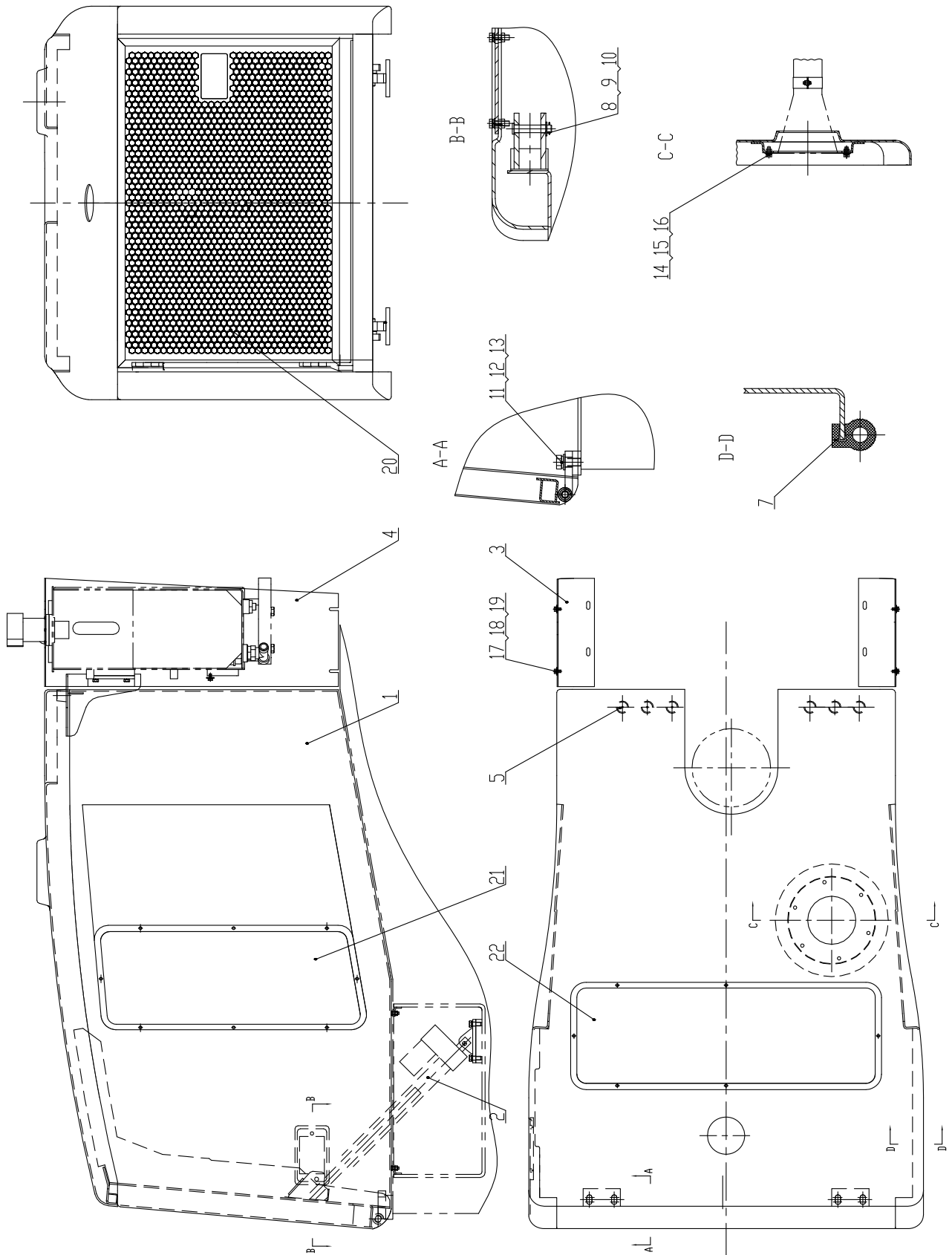

## Z38G12T1 车身车架（四） Frame Group（IV）

序号 No.	代号 Part No.	名称 Part Name		数量 Q'ty	备注 Remark
1	Z38G120901T2	机罩体	Main Hood	1	
2	D24-21B5-12	电动执行器	Electrak	1	
3	Z38G12090100001	油箱左护板	Left Plate	1	
4	Z38G12090100002	油箱右护板	Right Plate	1	
5	Z50G120900004T15	橡胶块	Rubber	6	
7		胶条L=1.7m	Rubber	2	
8	GB/T882-2000	销轴B12×60	Pin	2	
9	GB/T91-2000	销3.2×40	Pin	2	
10	GB/T95-2002	垫圈12	Washer 12	2	
11	GB/T5783-2000	螺栓M16×50	Bolt M16×50	6	
12	GB/T93-1987	垫圈16	Washer 16	6	
13	GB/T97.1-2002	垫圈16	Washer 16	6	
14	GB/T5783-2000	螺栓M10×35	Bolt M10×35	6	
15	GB/T93-1987	垫圈10	Washer 10	10	
16	GB/T97.1-2002	垫圈10	Washer 10	10	
17	GB/T5783-2000	螺栓M8×15	Bolt M8×15	8	
18	GB/T93-1987	垫圈8	Washer 8	8	
19	GB/T96.1-2002	垫圈8	Washer 8	8	
20	Z38G1209011T1	后门	Rear Door	1	
21	Z38G120901001T1	孔板	Plate	2	
22	Z38G120901002T1	孔板	Plate	1	

驾驶室

Cab

# Z38G13T2 驾驶室 Cab

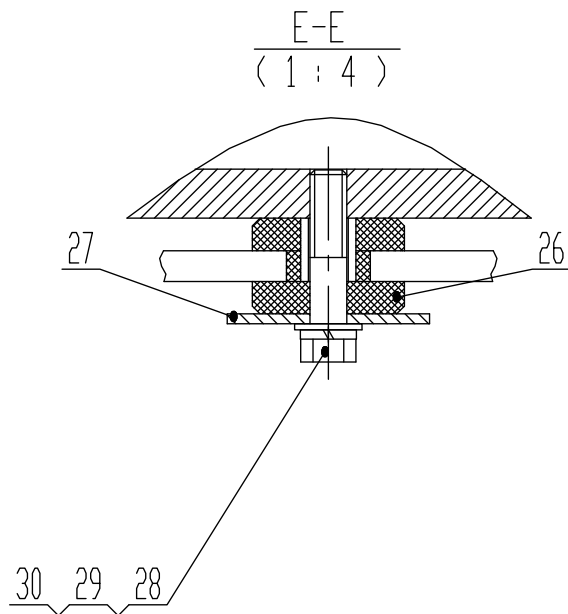
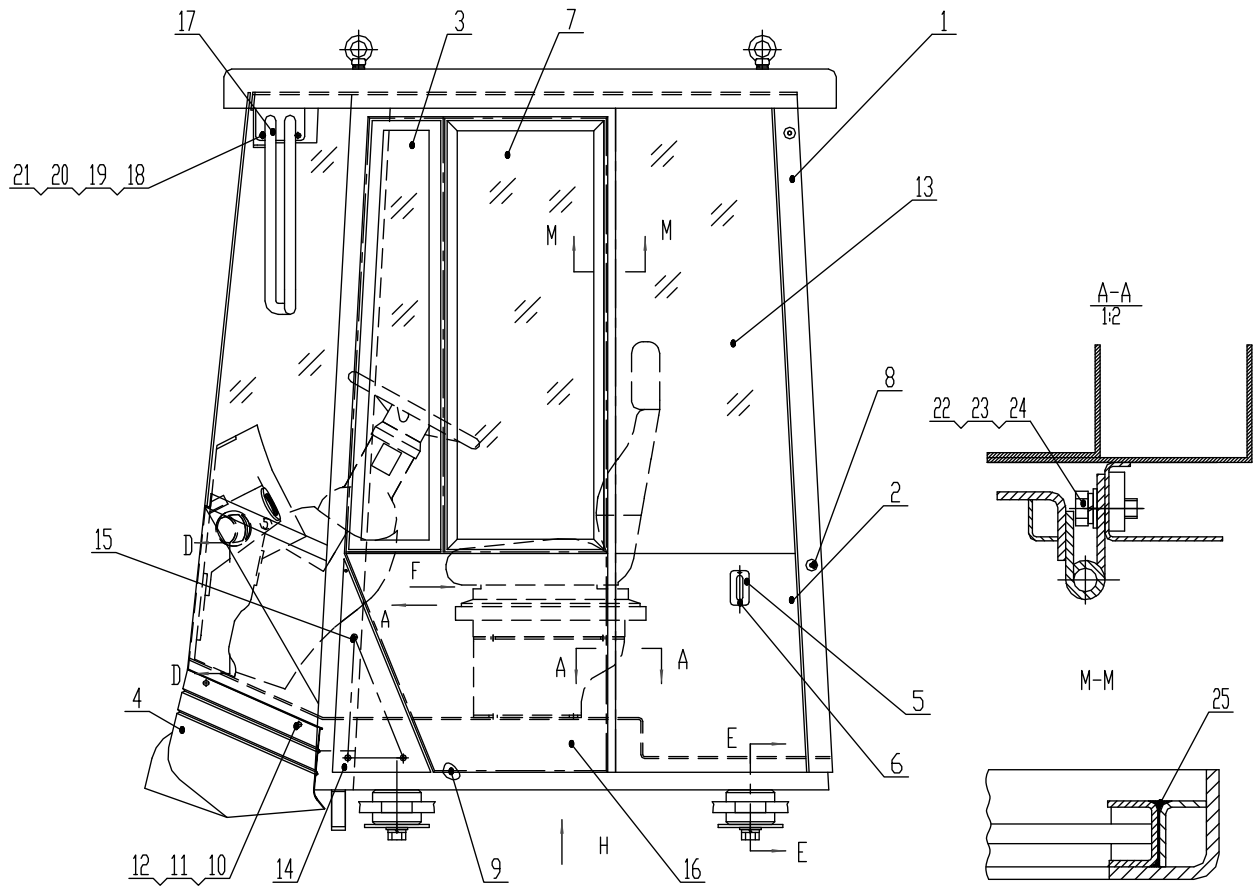

### Z38G13T2 驾驶室 Cab

序号	代号	名 称		数量	备注
Item	Part No	Parts Name		Q'ty	Remark
1	Z38G1301T2	机棚	Cab Body	1	
2	Z38G1302T2	内装饰	Adorning Assembly	1套	外购丽华
3	Z50G130000014T15	门小玻璃	Glass	2	借用满足CE要求分左右台玻
4	Z38G1304T2	前围板	Boarding	1	
5	Z50G130000026T15	锁孔盖板	Sheet	1	外购借用
6	GB/T5283-1985	螺钉ST4.2X16	Bolt ST4.2X16	2	表面处理 A5U
7	Z50G1307T15	推拉窗总成	Glass	2	借用外购泰兴锐拓
8	Z50G1308T15	门垫	Underlay	2	借用
9	Z50G130000018T15	门胶条	Glue	2	借用外购邢台
10	GB/T5783-2000	螺栓M8X30	Bolt M8X30	7	表面处理 达克罗
11	GB/T93-1987	垫圈8	Washer 8	7	表面处理 达克罗
12	GB/T96.1-2002	垫圈8	Washer 8	7	表面处理 达克罗
13	Z38G130000017T2	后侧窗玻璃	Glass	2	满足CE要求分左右台玻
14	Z50G130100001T15	三角封板	Sheet	2	借用分左右
15	M8X30GB/T68-2000	螺钉	Bolt	6	表面处理 达克罗
16	Z50G130103T15	左车门	Door	2	借用分左右
17	Z50G130105T15	倒车镜支架	Bracket	2	借用分左右
18	GB/T5783-2000	螺栓M8X25	Bolt M8X25	8	表面处理 达克罗
19	GB/97.1-2002	垫圈8	Washer 8	8	表面处理 达克罗
20	GB/T93-1987	垫圈8	Washer 8	8	表面处理 达克罗
21	Z50G130100018T15	倒车镜架座	Sheet	2	借用分左右
22	GB/T5783-2000	螺栓M10X25	Bolt M10X25	12	表面处理 达克罗
23	GB/97.1-2002	垫圈10	Washer 10	12	表面处理 达克罗
24	GB/T93-1987	垫圈10	Washer 10	12	表面处理 达克罗
25	Z50G130000024T15	玻璃胶	Glue	台套	借用由玻璃厂提供
26	CB-2205-77	减震器	Shock Absorber	4	外购洛德
27	Z50G130000019T15	垫板	Sheet	4	借用表面镀锌
28	GB/T5786-2000	螺栓M24X2X150	Bolt M24X2X150	4	表面处理 达克罗
29	GB/T93-1987	垫圈24	Washer 24	4	表面处理 达克罗
30	GB/T97.1-2002	垫圈24	Washer 24	4	表面处理 达克罗

Z38G13T2 驾驶室 Cab

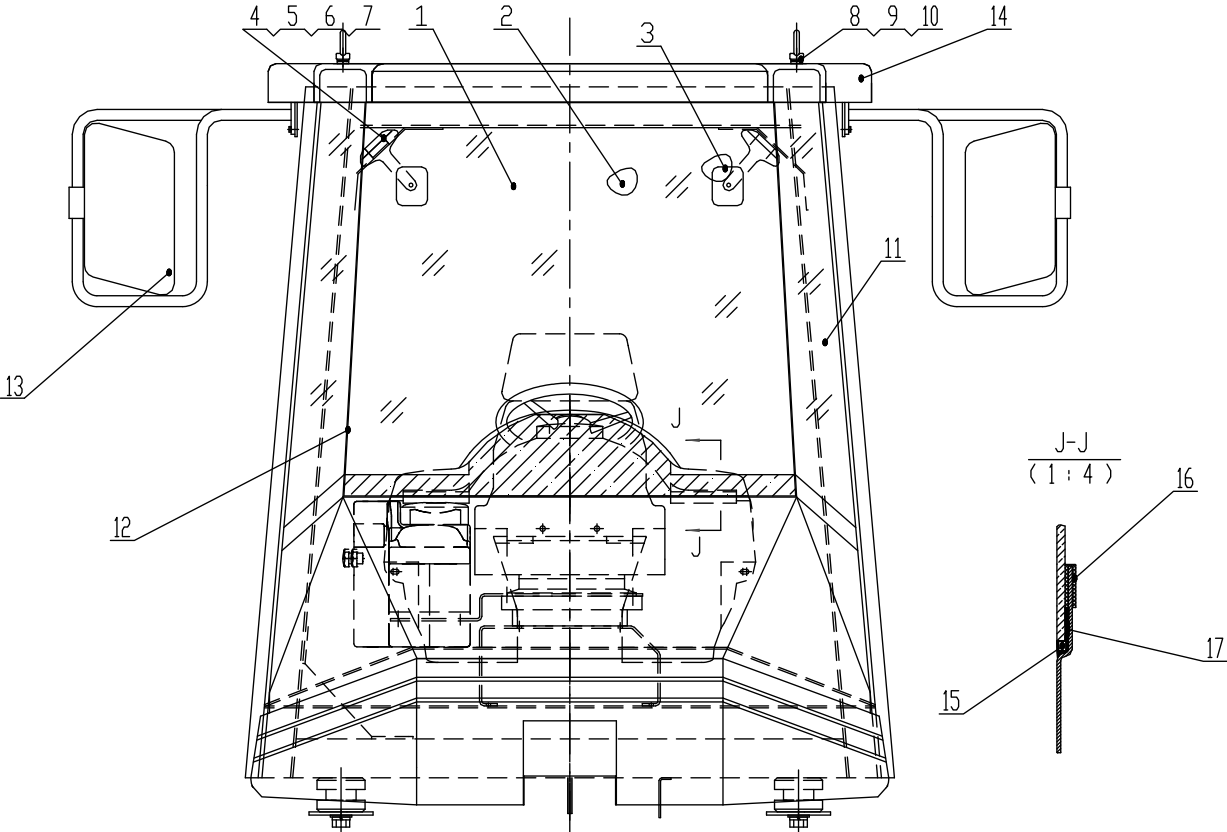

### Z38G13T2 驾驶室 Cab

序号	代号	名 称		数量	备注
Item	Part No	Parts Name		Q' ty	Remark
1	Z38G130000012T2	前窗玻璃	Glass	1	满足CE要求 台玻
2	Z38G130000016T2	后窗玻璃	Glass	1	满足CE要求 台玻
3	2020型	内视镜	Glass	2	外购丹阳
4	Z50G130100021T15	内视镜架	Bracket	2	借用
5	GB/T5783-2000	螺栓M6X16	Bolt M6X16	4	表面处理 达克罗
6	GB/97.1-2002	垫圈6	Washer 10	4	表面处理 达克罗
7	GB/T93-1987	垫圈6	Washer 10	4	表面处理 达克罗
8	GB/T825-1988	吊环螺钉M16	Bolt M16	4	表面处理 达克罗
9	Z50G130100011T15	橡胶垫	Glue	4	借用外协
10	Z50G130100012T15	垫板	Sheet	4	借用
11	Z50G130000013T15	前侧窗玻璃	Glass	2	借用满足CE要求分 左右 台玻
12	Z50G130000025T15	玻璃胶(白色)	Glue	台套	借任由玻璃厂提供
13	938型	倒车镜	Glass	2	外购丹阳
14	Z38G130102T2	外顶盖	Coping	1	
15	Z50G130000024T15	玻璃胶	Glue	台套	借任由玻璃厂提供
16	Z50G130000023T15	胶条	Glue	1套	借任由玻璃厂提供
17	Z50G130000029T15	泡沫条	Foam	1套	借任由玻璃厂提供



Z38G13T2 驾驶室 Cab

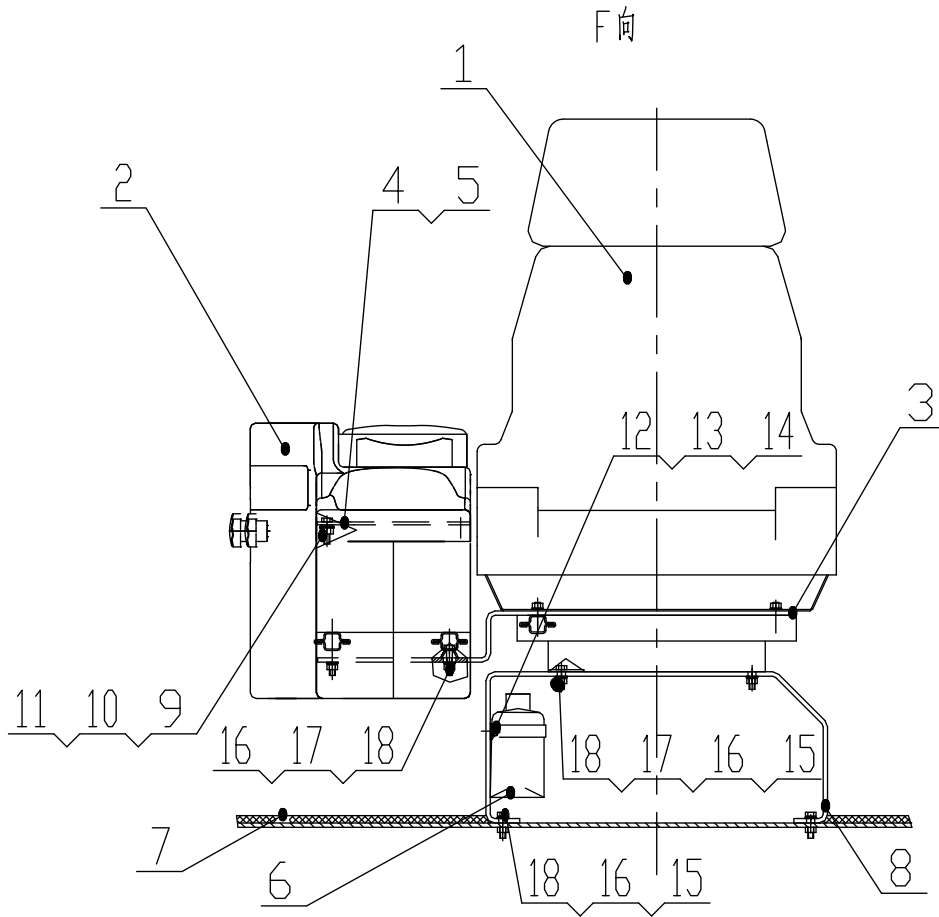

## Z38G13T2 驾驶室 Cab

序号	代号	名 称		数量	备注
Item	Part No	Parts Name		Q' ty	Remark
1	MSG85/722	座椅	Seat	1	外购格拉默
2	Z50G1305T15	操纵箱总成	Control Box Assembly	1	借用外购华田
3	Z50G13000009T15	操纵箱连接板	Sheet	1	借用
4	Z50G13000006T15	先导安装板	Sheet	1	借用安装 三联
5	Z50G13000007T15	先导安装板	Sheet	1	借用安装 HUSCO
6	MFJL-450	灭火器	Fire Extinguisher	1	外购镇江韩友
7	Z38G13000011T2	地板垫	Floor Board Cushion	1	外协
8	Z50G13000008T15	座椅连接板	Sheet	1	借用
9	GB/T5783-2000	螺栓M10X30	Bolt M10X30	4	表面处理 达克罗
10	GB/T93-1987	垫圈10	Washer 10	4	表面处理 达克罗
11	GB/T97.1-2002	垫圈10	Washer 10	4	表面处理 达克罗
12	GB/T818-2000	螺钉M6X16	Bolt M6X16	2	表面处理 达克罗
13	GB/T93-1987	垫圈6	Washer 6	2	表面处理 达克罗
14	GB/T97.1-2002	垫圈6	Washer 6	2	表面处理 达克罗
15	GB/T5783-2000	螺栓M8X30	Bolt M8X30	8	表面处理 达克罗
16	GB/T93-1987	垫圈8	Washer 8	12	表面处理 达克罗
17	GB/T6170-2000	螺母M8	Nut M8	8	表面处理 达克罗
18	GB/T97.1-2002	垫圈8	Washer 8	12	表面处理 达克罗

# Z38G13T2 驾驶室 Cab

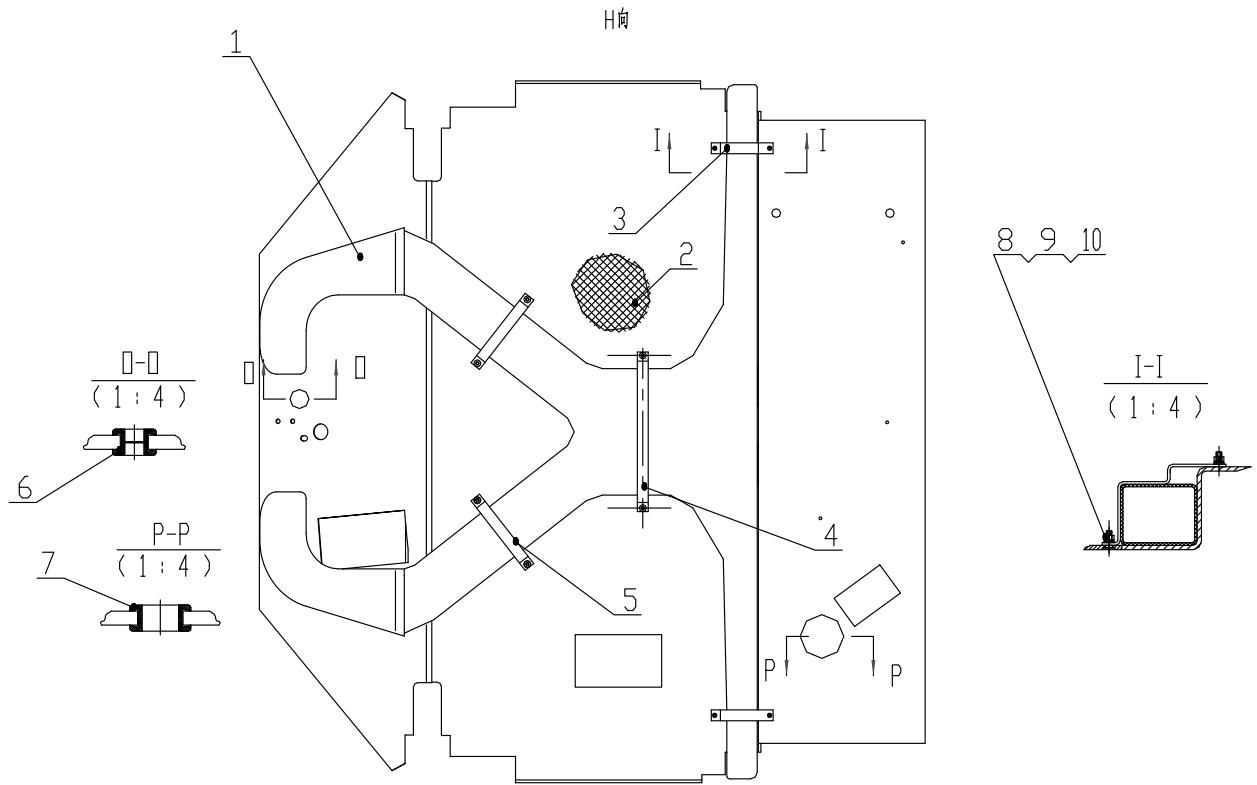

### Z38G13T2 驾驶室 Cab

序号	代号	名 称		数量	备注
Item	Part No	Parts Name		Q' ty	Remark
1	Z38G1306T2	风道总成	Place With a Draught	1	外购丽华
2	Z38G1309T2	泡沫	Foam	台套	外协华田
3	Z50G130000020T15	风道固定卡（一）	Bracket	2	借用
4	Z50G130000021T15	风道固定卡（二）	Bracket	1	借用
5	Z50G130000022T15	风道固定卡（三）	Bracket	2	借用
6	Z50G130000027T15	保护套	Rubber	1	借用外协科华
7	Z50G130000028T15	保护套	Rubber	1	借用外协科华
8	GB/T93-1987	垫圈6	Washer 6	10	表面处理 达克罗
9	GB/T97.1-2002	垫圈6	Washer 6	10	表面处理 达克罗
10	GB/T6170-2000	螺母M6	Nut M6	10	表面处理 达克罗

# Z38G13T2 驾驶室 Cab

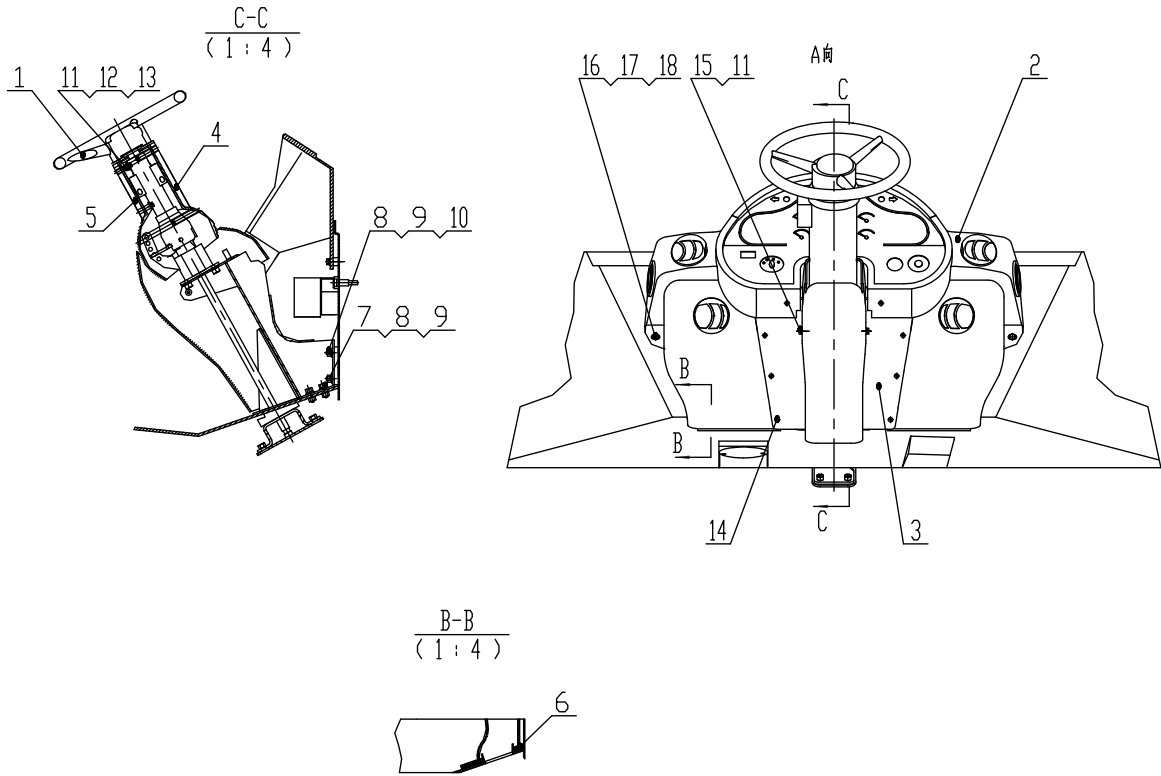

### Z38G13T2 驾驶室 Cab

序号	代号	名 称		数量	备注
Item	Part No	Parts Name		Q' ty	Remark
1	Z50G1303T15	方向机	Steering Wheel	1	借用外协华田
2	Z50G130000001T15	仪表台	Instrument Assemble	1	借用外购华田
3	Z50G130000002T15	下包壳	Wrap	1	借用外购华田
4	Z50G130000003T15	上前包壳	Wrap	1	借用外购华田
5	Z50G130000004T15	上后包壳	Wrap	1	借用外购华田
6	Z38G1309T2	泡沫	Foam	台套	外协华田
7	GB/T5783-2000	螺栓M10X30	Bolt M10X30	4	表面处理 达克罗
8	GB/T93-1987	垫圈10	Washer 10	8	表面处理 达克罗
9	GB/T97.1-2002	垫圈10	Washer 10	8	表面处理 达克罗
10	GB/T6170-2000	螺母M10	Nut M10	4	表面处理 达克罗
11	GB/T818-2000	螺钉M6X16	Bolt M6X16	10	表面处理 达克罗
12	GB/T93-1987	垫圈6	Washer 6	8	表面处理 达克罗
13	GB/T97.1-2002	垫圈6	Washer 6	8	表面处理 达克罗
14	GB/T819.1-2000	螺钉M6X16	Bolt M6X16	8	表面处理 达克罗
15	GB/T96.1-2002	垫圈6	Washer 6	2	表面处理 达克罗
16	GB/T5783-2000	螺栓M8X30	Bolt M8X30	2	表面处理 达克罗
17	GB/T93-1987	垫圈8	Washer 8	2	表面处理 达克罗
18	GB/T6170-2000	螺母M8	Nut M8	2	表面处理 达克罗

Z38G14T2 工作装置

Implement

# Z38G14T2 工作装置（一） Implement ( I )

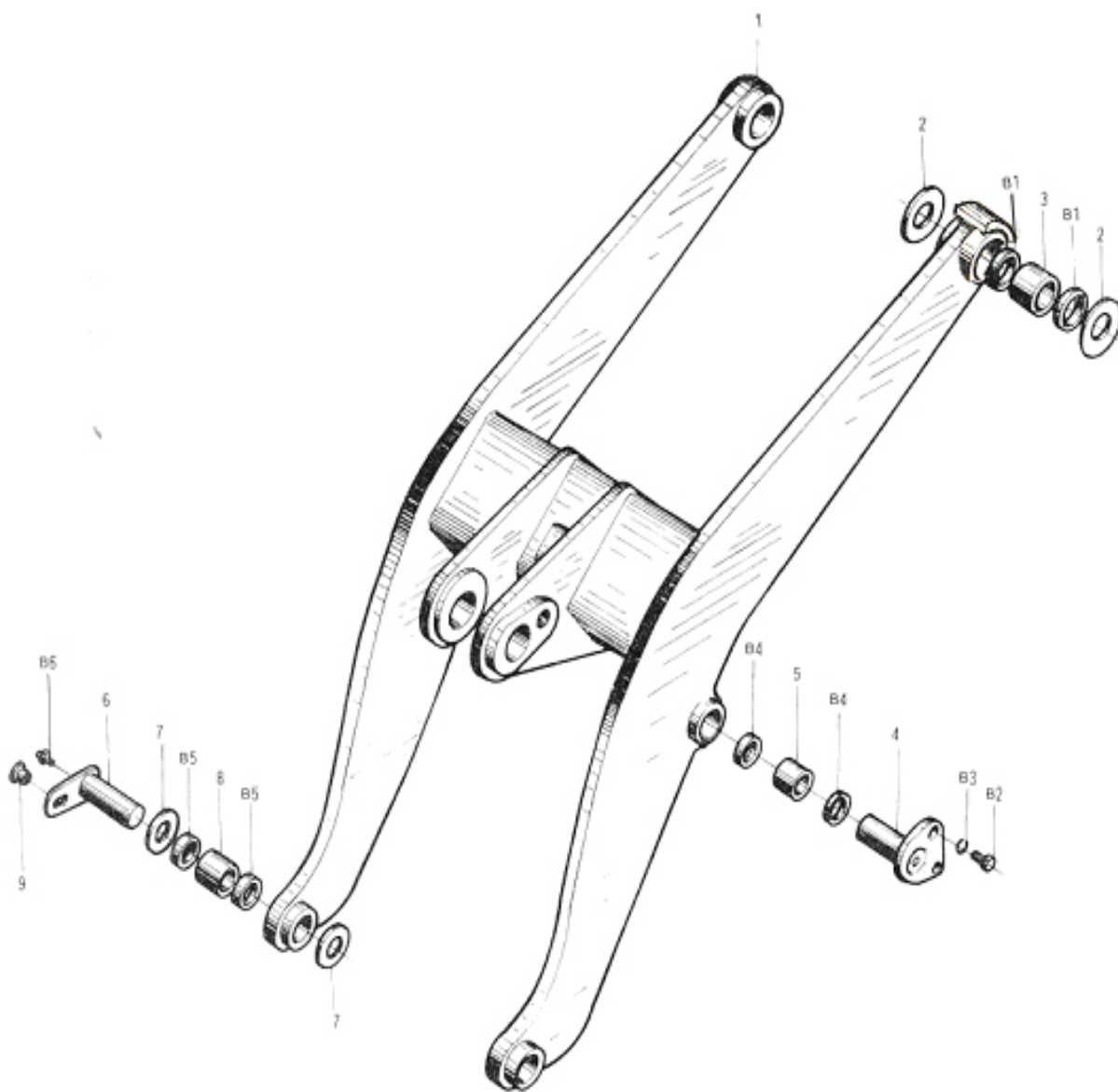



## Z38G14T2 工作装置（一） Implement ( I )

序号 Item	代号 Part No.	名 称 Parts Name		数量 Q'ty	备注 Remark
1	Z38G1402	动臂	Arm	1	
2	Z30140000005	垫片	Washer	2	
3	Z30140000006	轴套	Bushing	2	
4	Z301409	销轴	Pin Shaft	2	
5	Z30140000007	轴套	Bushing	2	
6	Z301410	销轴	Pin Shaft	2	
7	Z30140000009	垫片	Washer	2	
8	Z30140000008	轴套	Bushing	2	
9	Z30140000001	螺栓套	Bushing	6	
B1	HG4-692-67	骨架式橡胶油封PD60X80X12	Skeleton Dust Seal Ring PD60X80X12	8	
B2	GB/T 5783-2000	螺栓 M12X30	Bolt M12X30	4	
B3	GB/T93-1987	弹簧垫圈 12	Washer 12	4	
B4	HG4-692-67	骨架式橡胶油封PD50X70X12	Skeleton Dust Seal Ring PD50X70X12	4	
B5	HG4-692-67	骨架式橡胶油封PD55X75X12	Skeleton Dust Seal Ring PD55X75X12	4	
B6	JB/T7940.1-1995	油杯 M10X1	Oil Cup M10X1	8	

## Z38G14T2 工作装置（二） Implement (II)

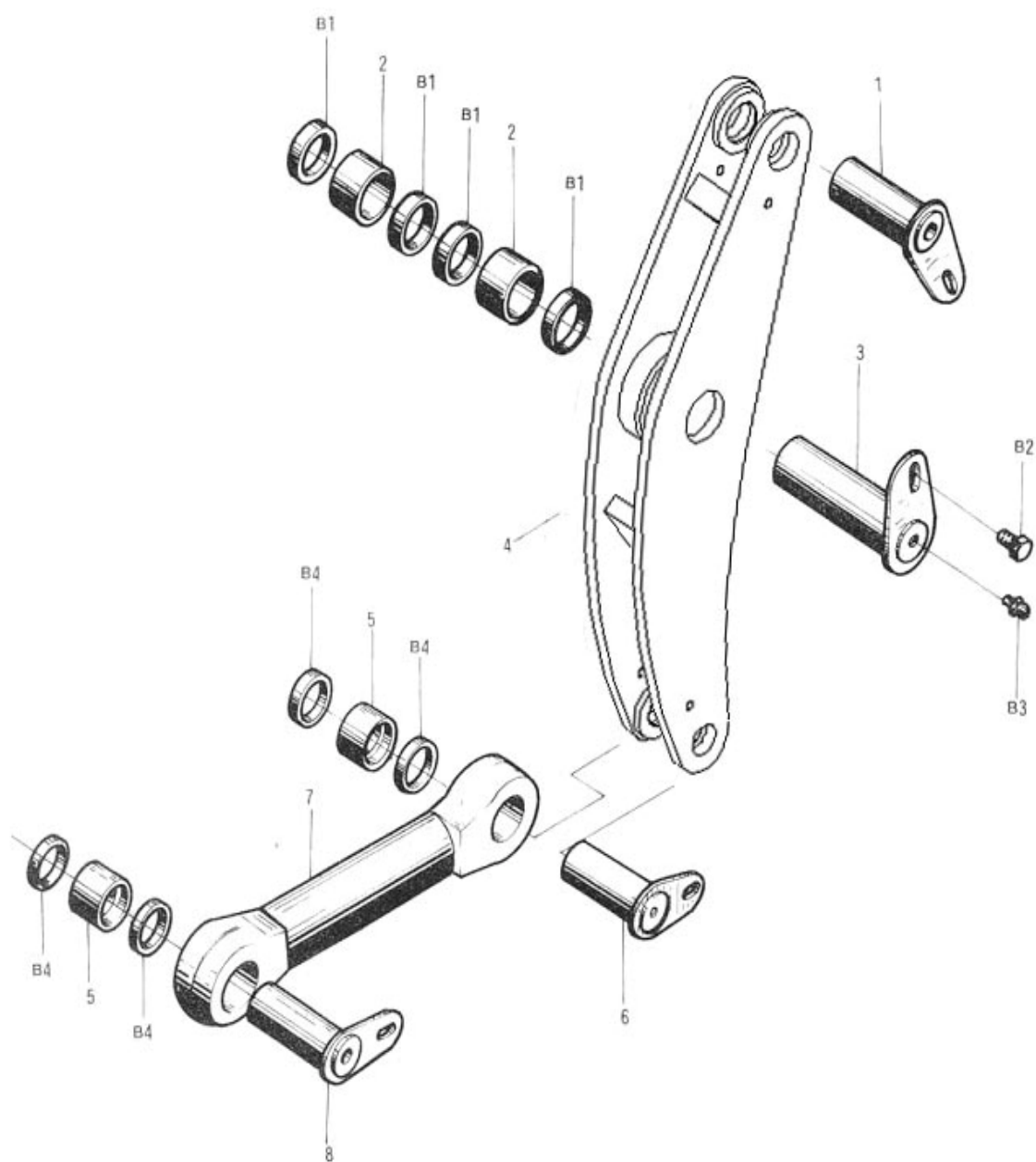

## Z38G14T2 工作装置（二） Implement（II）

序号 Item	代号 Part No.	名 称 Parts Name		数量 Q'ty	备注 Remark
1	Z301414	销轴	Pin Shaft	1	
2	Z3014000003	轴套	Bushing	2	
3	Z301406	销轴	Pin Shaft	1	
4	Z301413	摇臂	Rocker	1	
5	Z3014000002	轴套	Bushing	2	
6	Z301408	销轴	Pin Shaft	1	
7	Z301407	拉杆	Pull Rod	1	
8	Z301404	销轴	Pin Shaft	1	
B1	HG4-692-67	骨架式橡胶油封PD80X100X12	Skeleton Dust Seal Ring PD80X100X12	4	
B2	GB5783-86	螺栓 M20X35	Bolt M20X35	6	
B3	GB1152-89	油杯 M10X1	Oil Cup M10X1	8	
B4	HG4-692-67	骨架式橡胶油封PD60X80X12	Skeleton Dust Seal Ring PD60X80X12	8	

# Z38G14T2 工作装置（三） Implement (III)

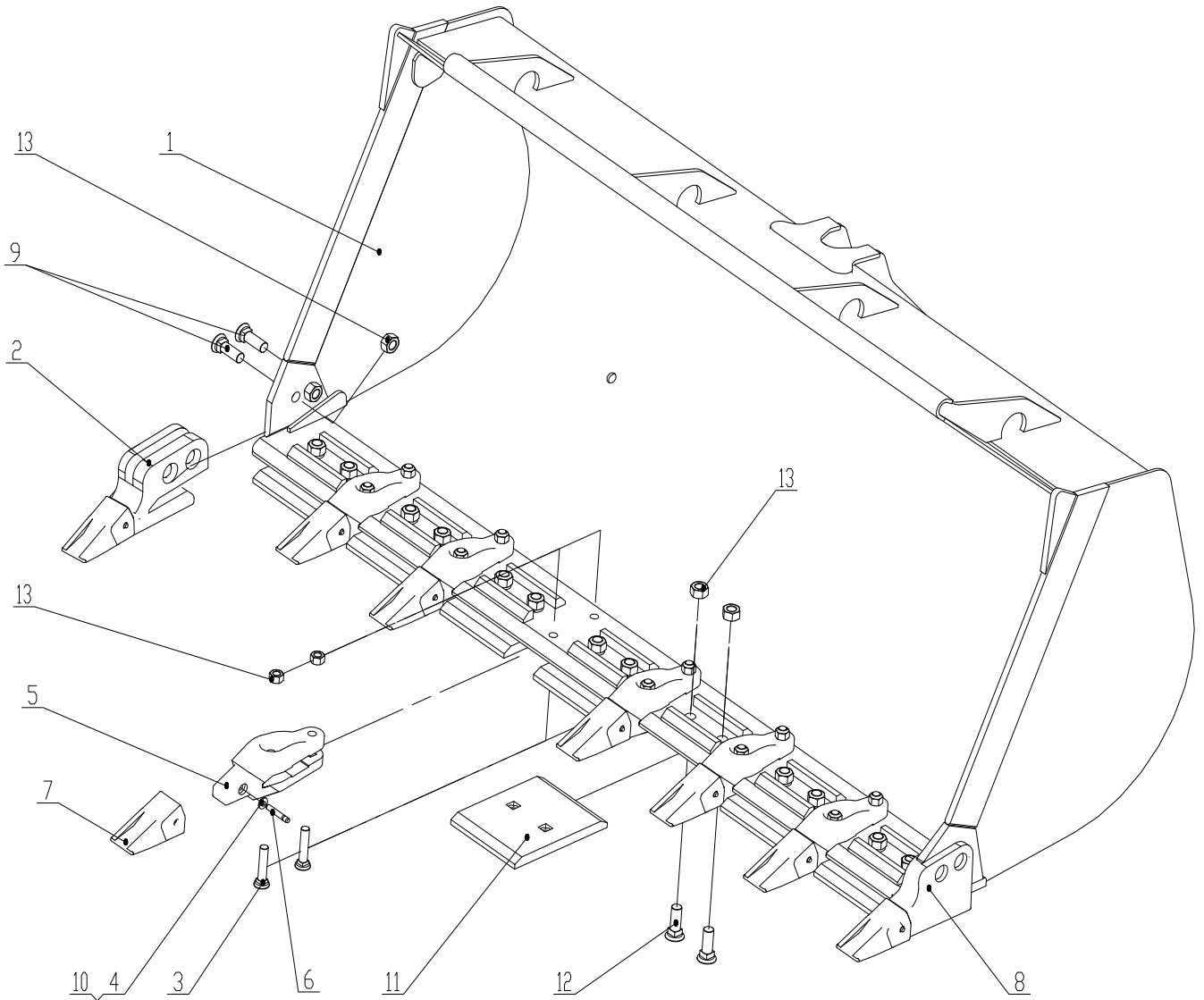

### Z38G14T2 工作装置（三） Implement (III)

序号 Item	代号 Part No.	名 称 Parts Name		数量 Q'ty	备注 Remark
1	Z38G140101B	铲斗	Bucket	1	
2	Z30140100001A	右侧斗齿体	Teeth	1	
3	Z30140100010	螺栓	Bolt	12	
4	Z30141000003	卡环	Clip	8	
5	Z30140200001A	斗齿体	Bucket Tooth	6	
6	Z30140100002	销轴	Pin Shaft	8	
7	Z30140100004A	齿靴	Boot-Bucket Tooth	8	
8	Z30141100001A	左侧斗齿体	Teeth	1	
9	Z30140100011	螺栓	Bolt	4	
10	Z30140100005	橡胶皮套	Rubber Cover	8	
11	Z38G140100001B	可卸防磨板	Assemble Bucket Blade	7	
12	Z35F140000001	螺栓	Bolt	14	
13	GB/T 6170-2000	螺母M20	Nut M20	30	

# 电气系统

## **Electrical System**

# Z38G15T2 车架线路 Chassis Wiring

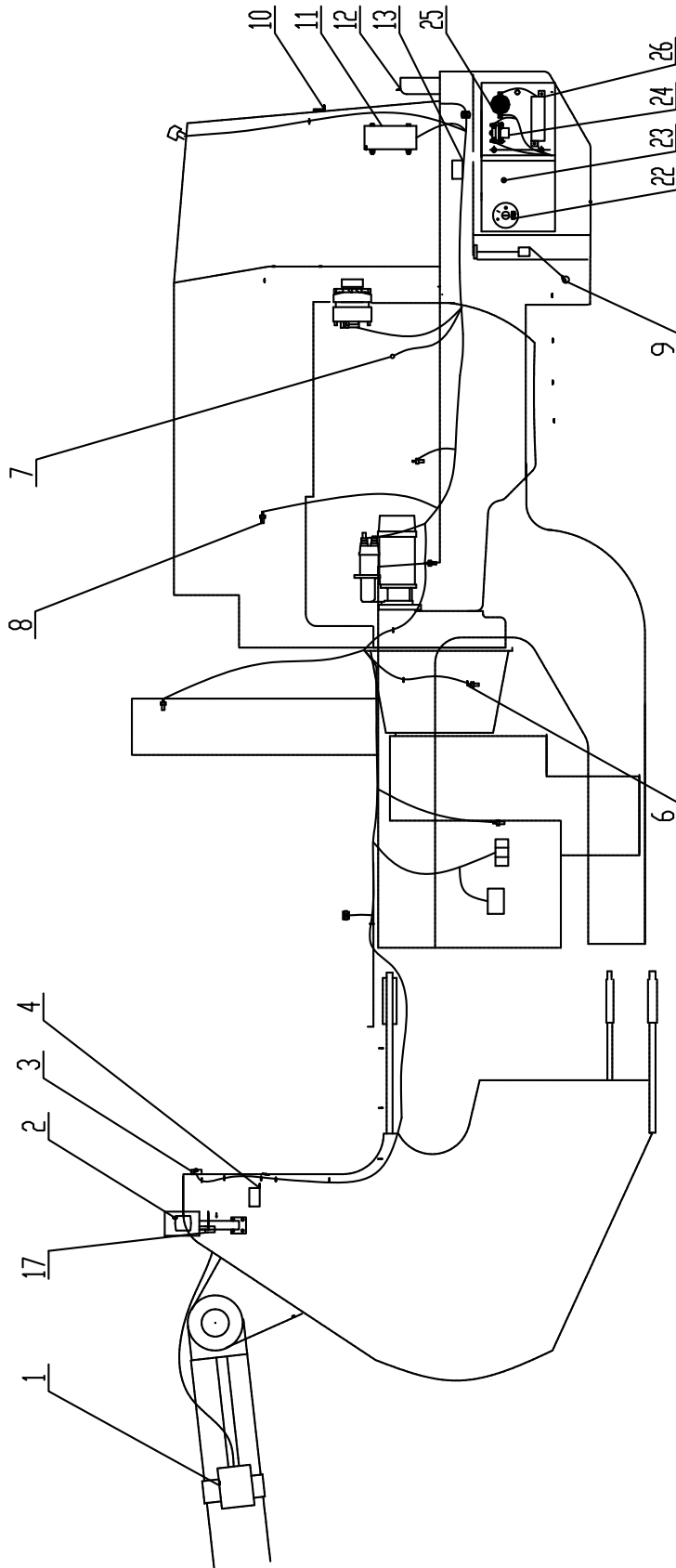

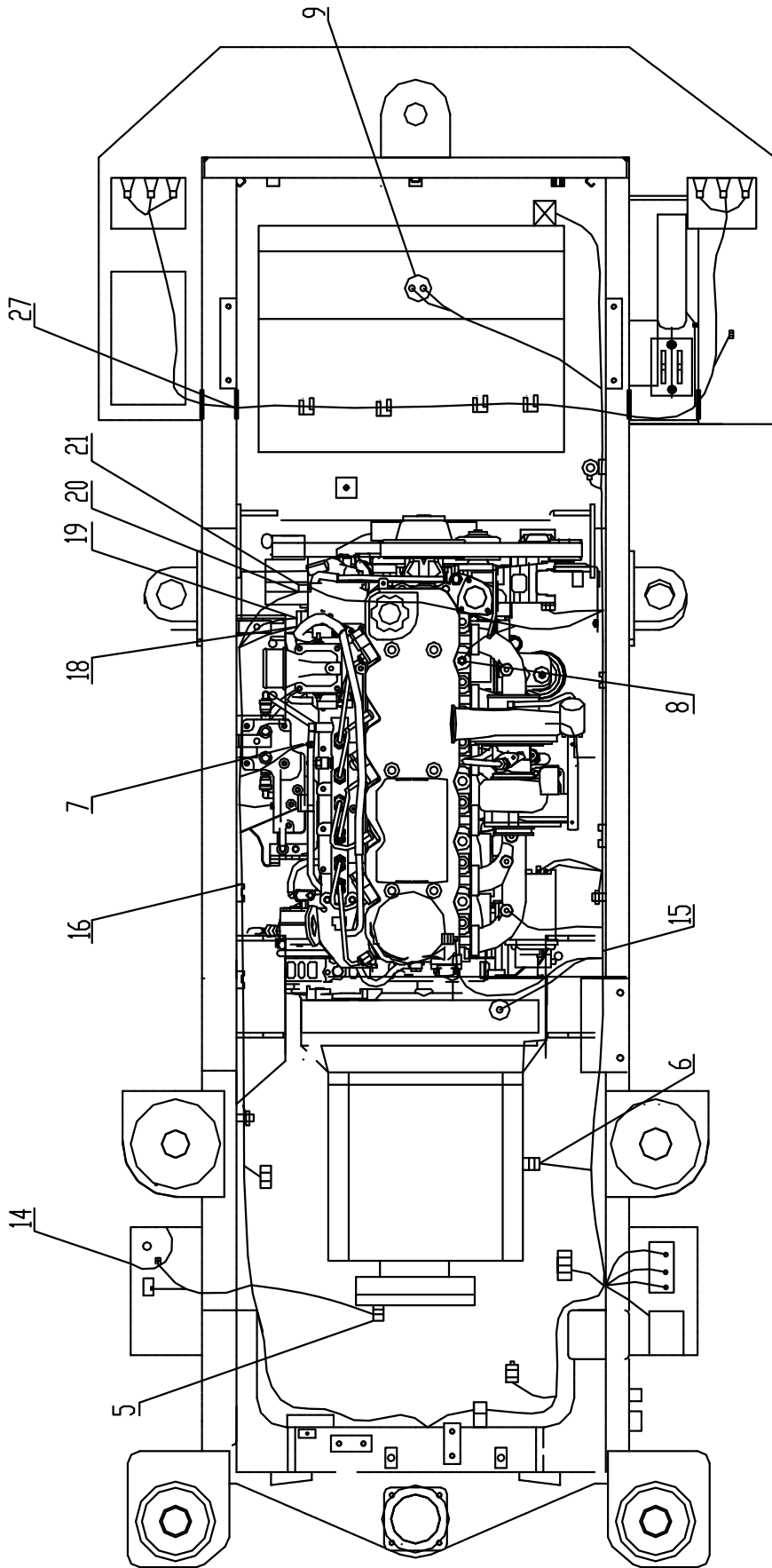

**Z38G15T2 电气元件 Electrical Component**



序号 No.	代 号 Part No.	名 称 Parts Name		数量 Q'ty	备 注 Remark
1	ZDSPK-1	铲斗找平控制器	Bucket Positioned CON	1	
2	CG.G	前组合灯	Front Combined Lamp	2	
3	ZDTSK-1	动臂提升控制器	Lift Kick-out Control	1	
4	F	前侧面反射器	Side Reflector	2	
5	M10×1	换档压力开关	T/C Oil Pressure SW	1	
6	M14×1.5	变矩器油温传感器	T/C Oil Temp Sensor	1	
7	NPT 1/8	机油压力传感器	Oil Pres. Sensor	1	
8	NPT 1/2	发动机水温传感器	Coolant Temp. Sensor	1	
9	226 801 015 001C	燃油传感器	Fuel Level Sensor	1	
10	T	后反射器（红色）	Tail Reflector	2	
11	3T1815	倒车报警器	Back-up alarm	1	
12	CG.M	后组合灯	Tail Combined Lamp	2	
13	M	车身反射器	Side Reflector	2	
14	30W/24V	洗涤器	Washer motor	1	
15	Z38G1503T2	车架线束	Chassis Harness	1	
16	Z38G150301T2	发动机线束	Engine Harness	1	
17	N024	电喇叭	Horn	1	
18	DTP06-4S	4 针连接器	Receptacle Kit(4 pin)	1	
19	DRC26-50S-04	50 针连接器	Receptacle Kit(50Pin)	1	
20	DTP06-3S	J1939 插座	Receptacle Kit(3 pin)	3	
21	DT04-3P	终端电阻	Terminating Resistor	3	
22	JK862A	电瓶负极开关	Battery Disconnect SW	1	
23	2NT1-7	后机罩倾翻开关	Hood Tilt SW	1	
24	MZJ-50A/006	启动继电器	Start Relay	1	
25	3916302	加热继电器	AIH Relay	1	
26	ANL 125A+PANL-C	单路熔断器总成	Fuse 125 A	1	
27	φ 60×35	护孔圈	Rubber Ring	2	

# Z38G15T2 机棚电气总成 Cab Electrical Equipment Group

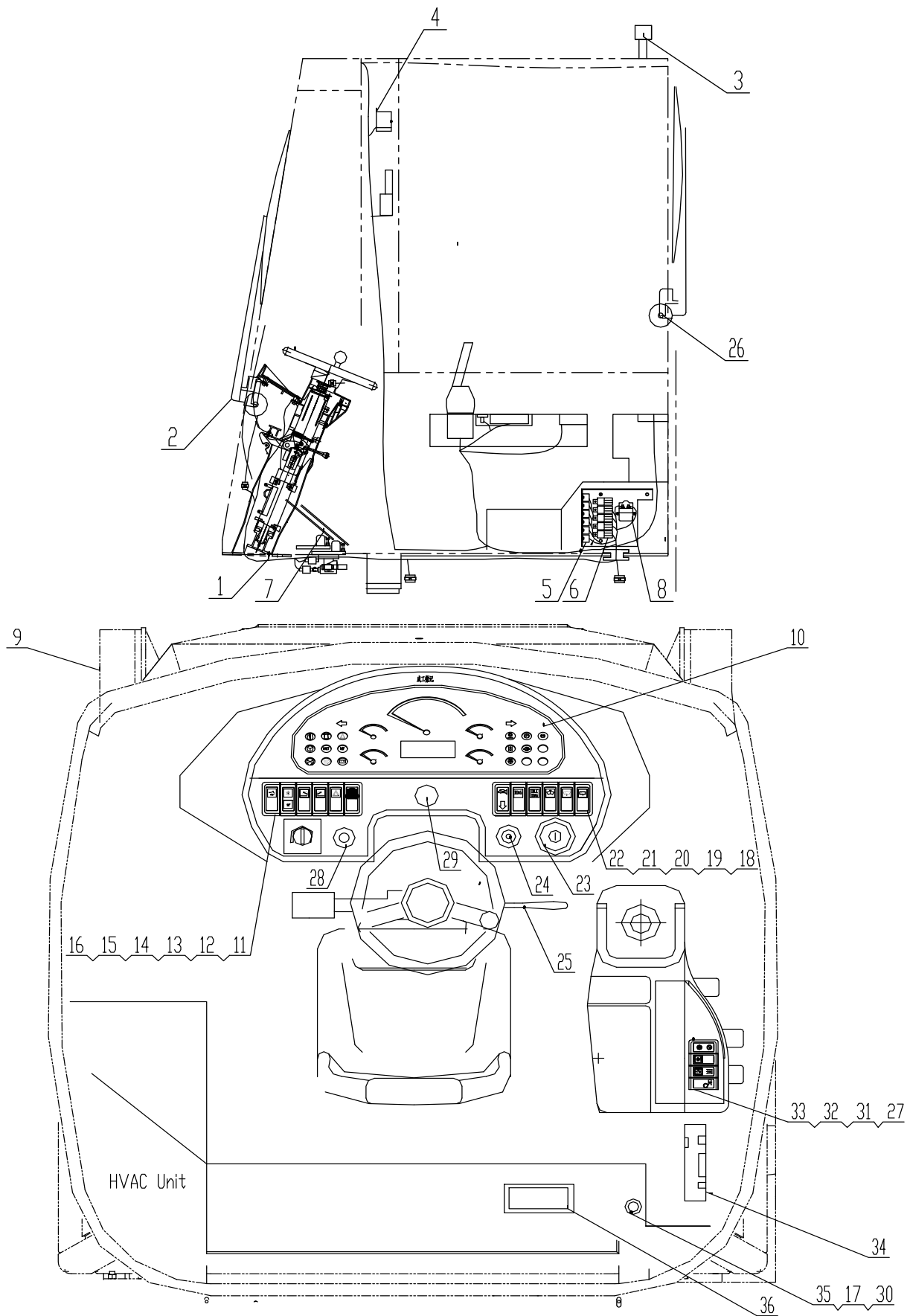

## Z38G15T2 电气元件 Electrical Component

序号 No.	代 号 Part No.	名 称 Parts Name		数量 Q'ty	备 注 Remark
1	Z38G1502T1	驾驶室线束	Cab Harness	1	
2	CG50G-B	前雨刮器	Front Window Wiper	2	
3	35.091.000.42	旋转警示灯	Rotating Beacon	1	
4	CG.F1 10W/24V	壁灯	Dome Lamp	2	
5	JQ201S-PLD	继电器	Relay	8	
6	JQ604	闪光器	Flasher	2	
7	WM526/350827	电控油门踏板	Electric Governor	1	
8	MZJ-100A/006	附件继电器	Main Relay	1	
9	CG.H	前工作灯	Front Flood Lamp	2	
10	DJC-10H	电子监测器	Electronic Monitor	1	
11	JK993-052 B-2.61B/2.61A	空调风量开关	Fan Speed SW	1	
12	JK993-052 B-2.38/2.37	空调模式开关	Heating and AC SW	1	
13	JK993-000-3.67	前工作灯开关	Front Flood Lamp SW	1	
14	JK993-000-3.67	后工作灯开关	Tail Flood Lamp SW	1	
15	JK993-000-2.4	应急警示灯开关	Hazard SW	1	
16	JK993-000-3.40	旋转警示灯开关	Rotating Beacon SW	1	
17	HDC16-9	诊断插座保护盖	Cab	1	
18	JK993-045-2.5	前窗雨刮开关	Front Wiper SW	1	
19	JK993-045-2.28	后窗雨刮开关	Front Wiper SW	1	
20	JK993-000-2.6	洗涤泵开关	Washer Motor SW	1	
21	JK993-065-8.1	怠速调整开关	Idle/Dia SW	1	
22	JK993-000-7.98	故障诊断开关	Diagnostic SW	1	
23	JK406	起动开关	Engine Start SW	1	
24	LP01012	点烟器	Cigarette Lighter	1	
25	303A	组合灯开关	Lamp SW	1	
26	CG50G-A	后雨刮器	Rear Window Wiper	1	
27	JK993-000-8.34	集中润滑开关	Intermediate Lube SW	1	
28	ZB2BS54C+ZB2BZ102C	停车制动按钮	Parking Button	1	
29	CZ-315	电源插座	24V Power Receptacle	1	
30	1060-16-0144	诊断插座插针	Pin	5	

31	JK993-000-12.61	车辆减震开关	Ride Control SW	1	
32	JK993-000-4.67/4.67	动力截断选择开关	SW	1	
33	JK993-000-13.44/13.43	操作锁止开关	Hydraulic Lock SW	1	
34	TK-727	收放机	Radio	1	
35	HD10-9-1939P	维修用插座	Service Tool Connector	1	
36	15713-24/16-2-1-A	24路保险	Fuse	1	

车载后视监控系统 Vehicle Rear Video System  
(Optional)

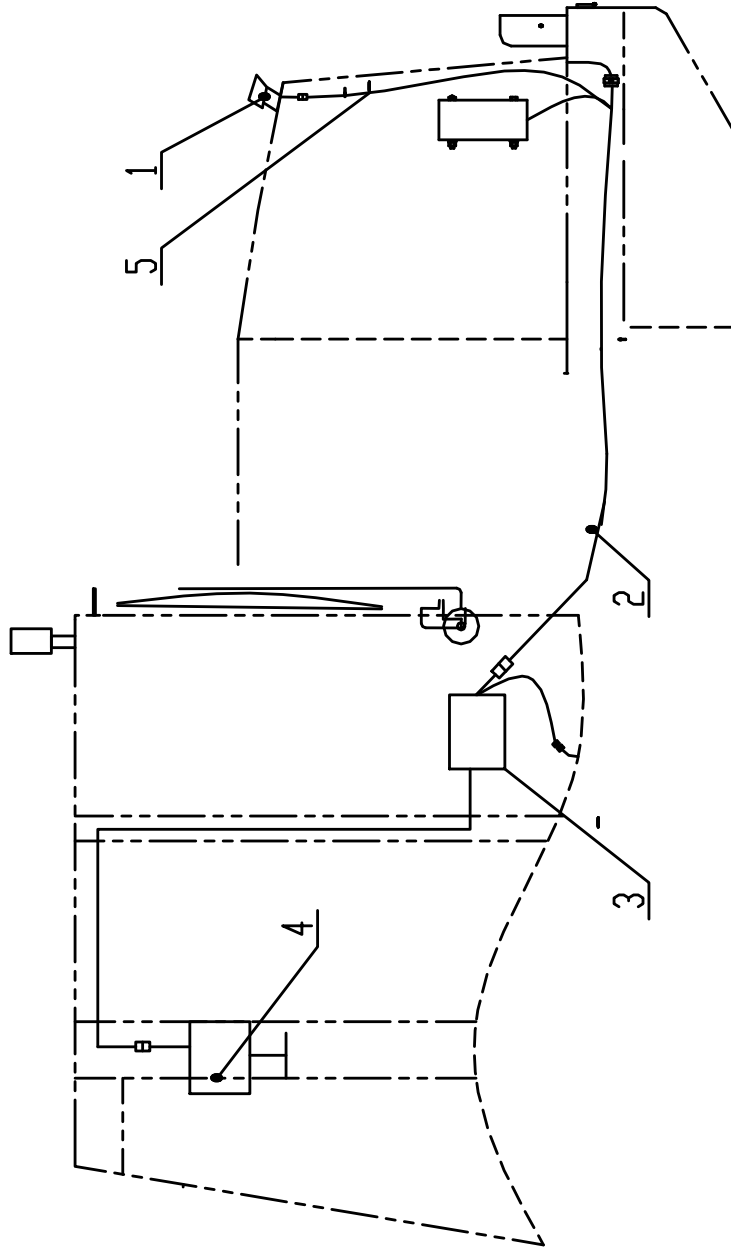

## Z38G15T2 电气元件 Electrical Component

序号 No.	代 号 Part No.	名 称 Parts Name		数量 Q'ty	备 注 Remark
1	AE-CM11B	红外摄像头	Camera	1	
2	L	后视线束	Harness	1	
3	AE-CB112	控制盒	Controller	1	
4	AE-TM56E	显示器	LCD	1	
5	JS-200T	扎带	Locking Cable Ties	5	

# Z38G15T2 电瓶线路 Battery Wiring

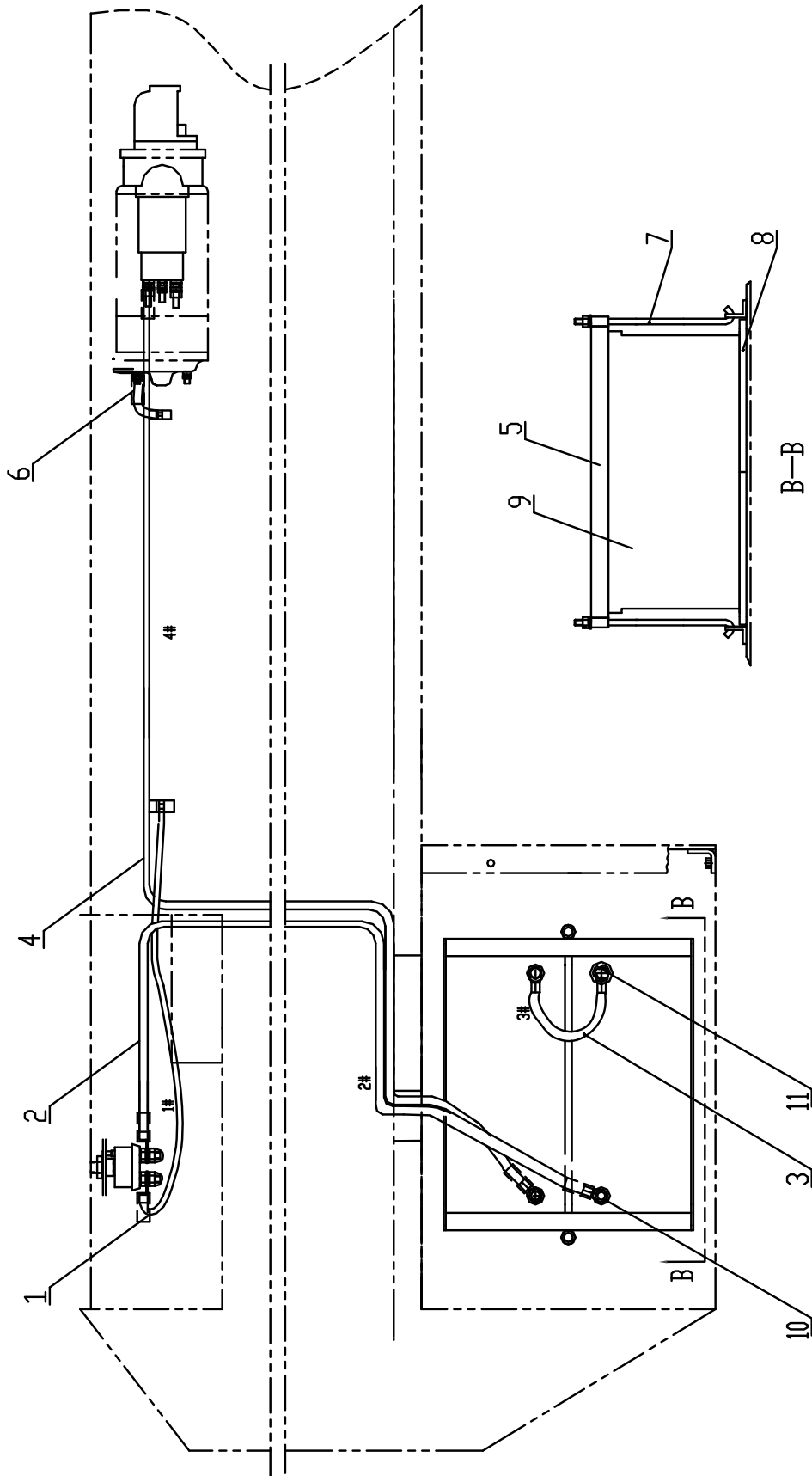

## Z38G15T2 电气元件 Electrical Component

序号 No.	代 号 Part No.	名 称 Parts Name		数量 Q'ty	备 注 Remark
1	Z38G150801T2	蓄电池导线 1#	Cable 1#	1	
2	Z38G150802T2	蓄电池导线 2#	Cable 2#	1	
3	Z38G150803T2	蓄电池导线 3#	Cable 3#	1	
4	Z38G150804T2	蓄电池导线 4#	Cable 4#	1	
5	Z50G150805T17	电池压框	Frame	1	
6	Z3B II 150800001	搭铁线	Ground Harness	1	
7	Z50G150800002	拉杆	Rod	2	
8	Z50G150800004	耐酸防震电池垫	Rubber Cushion	1	
9	6-QW-120B	蓄电池	Battery	2	
10	φ 25	烟斗型橡胶套	Cover (Black)	2	
11	φ 25	烟斗型橡胶套	Cover (Red)	2	



Z38G15T2 系统原理图 Electrical Schematic

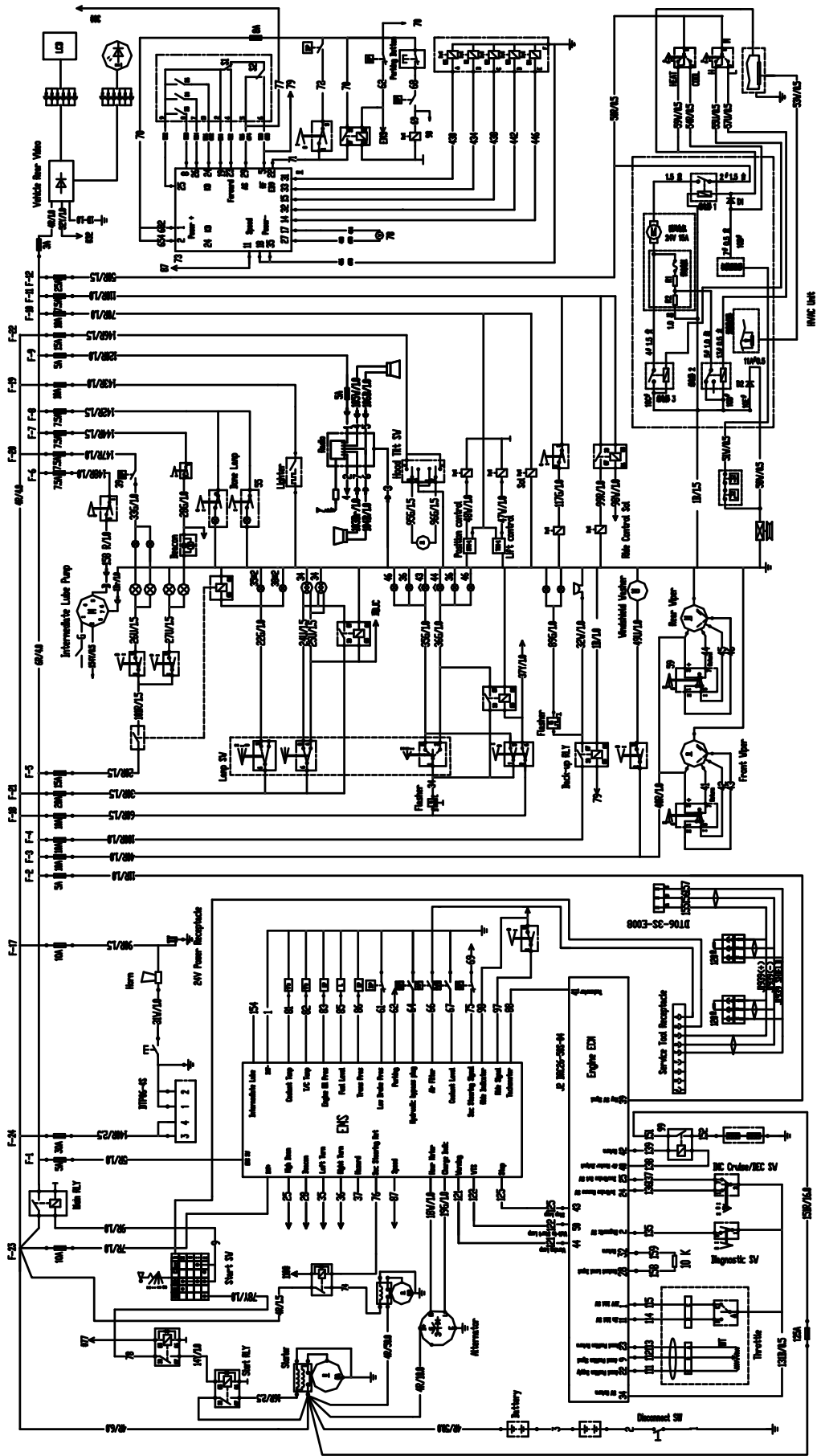

# 找平和提升装置

**Level Device**

# Z38G16T2 找平和提升装置 Level Device

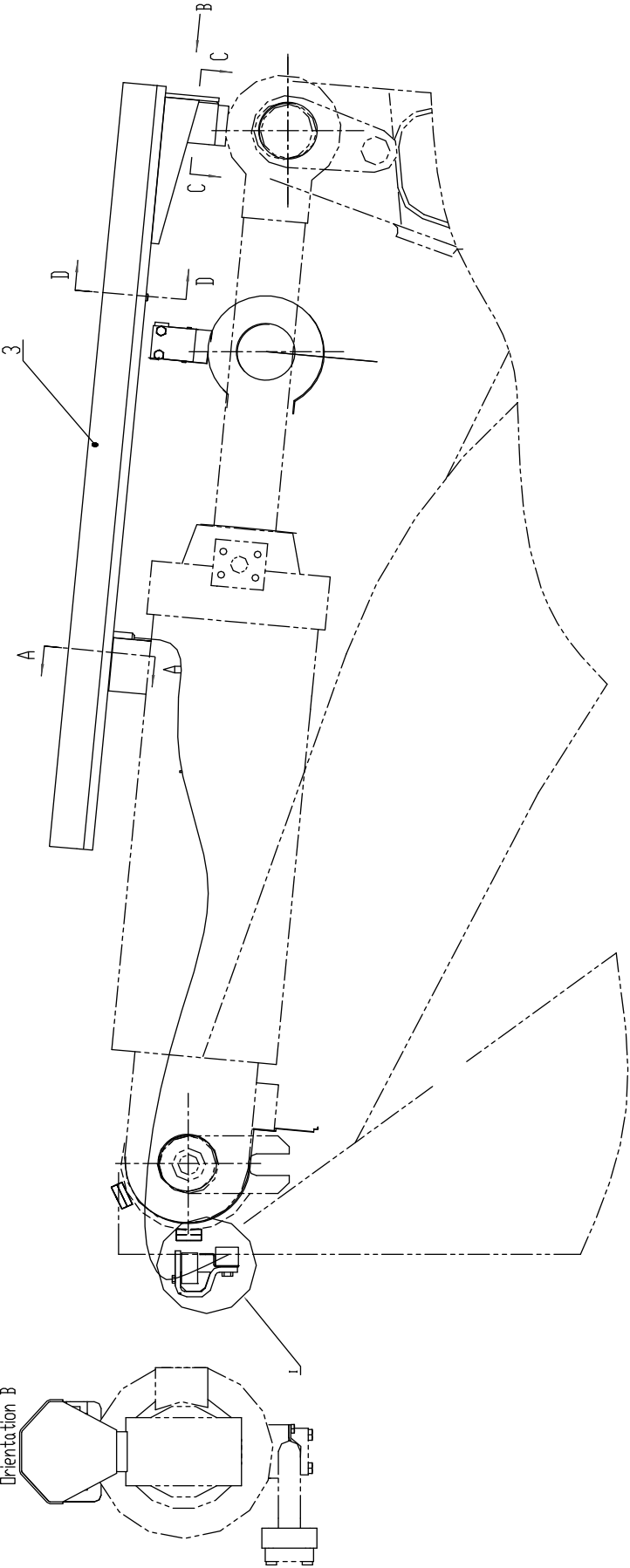

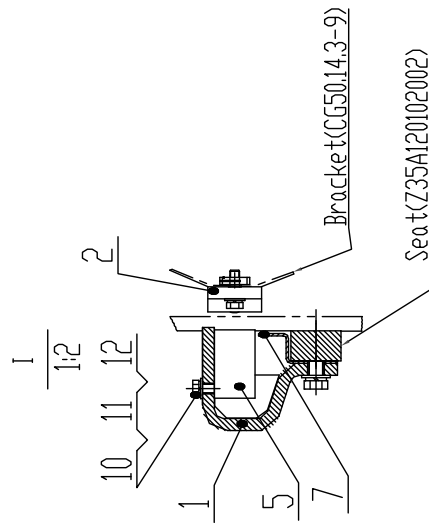
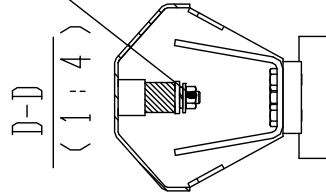
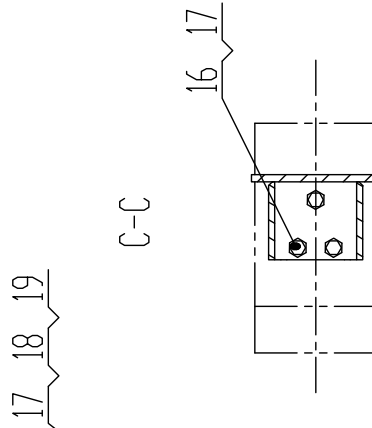
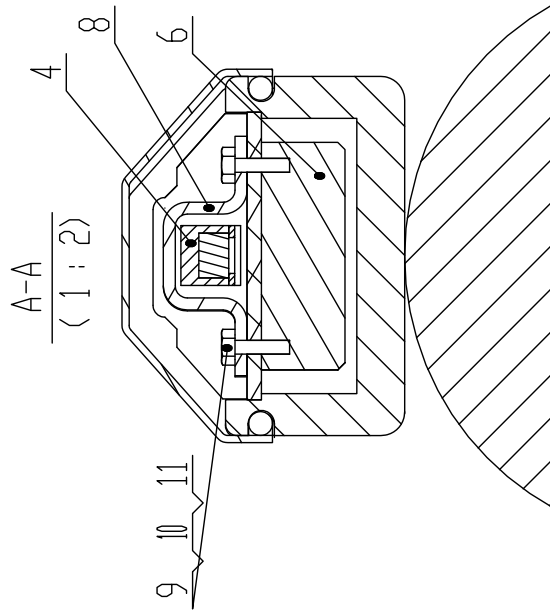

## Z38G16T2 找平和提升装置 Level Device

序号	代 号	名 称	数量	备注	
Item	Part No.	Parts Name	Q'ty	Remark	
1	Z35A1601B	提升控制器安装 支架	Bracket	1	
2	Z50G1603T17	提升磁钢安装座	Seat	1	
3	Z38G1601T2	防护罩总成	Cover	1	
4	Z38G1602T2	水平定位拉杆	Position Pole	1	
5	Z35A1607B	提升限位控制器	Controller	1	
6	Z35A1608B	水平定位控制器	Controller	1	
7	Z35A16000001B	挡泥板	Plate	1	
8	Z50G16000001T17	尺标架	Bracket	1	
9	GB/T 5783-2000	螺栓 M8×30	Bolt	2	
10	GB/T 93-1987	垫圈 8	Washer	4	
11	GB/T 97.1-2002	垫圈 8	Washer	4	
12	GB/T 5783-2000	螺栓 M8×30	Bolt	2	
13	GB/T 5783-2000	螺栓 M12×25	Bolt	2	
14	GB/T 93-1987	垫圈 12	Washer	2	
15	GB/T 97.1-2002	垫圈 12	Washer	2	
16	GB/T 70.1-2000	螺钉 M10X20	Screw	3	
17	GB/T 93-1987	垫圈 10	Washer	4	
18	GB/T 6177.1-2000	粗牙六角法兰面 螺母 M10	Nut	1	
19	GB/T 96.1-2002	垫圈 10	Washer	1	

### Z35A1601B 提升控制器安装支架 Bracket

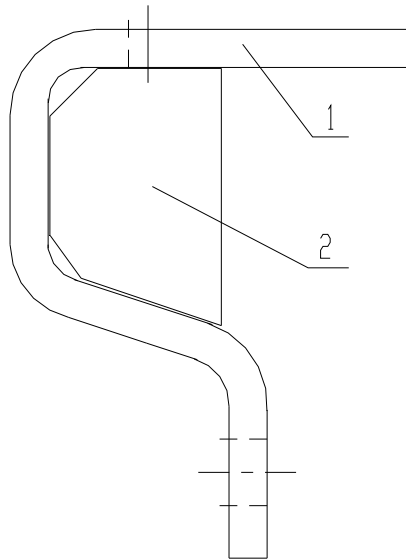

### Z35A1601B 提升控制器安装支架 Bracket

序号	代 号	名 称		数量	备注
Item	Part No.	Parts Name		Q'ty	Remark
1	Z35A160100001B	弯板	Plate	1	
2	Z35A160100002B	侧板	Plate	2	

### Z50G1603T17 提升磁钢安装座 Seat

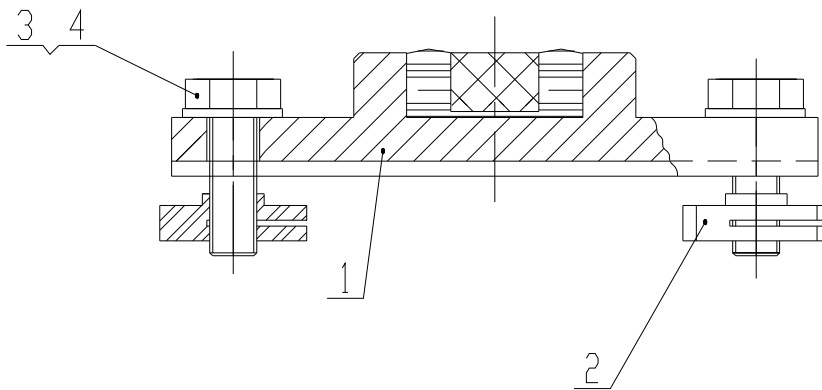

### Z50G1603T17 提升磁钢安装座 Seat

序号	代 号	名 称		数量	备注
Item	Part No.	Parts Name		Q'ty	Remark
1	Z35A160201B	磁钢座	Seat	1	
2	Z35A160200001B	小夹铁	Shim	2	
3	GB/T 5781-2000	螺栓 M8×25	Bolt	2	
4	GB/T 97.1-2002	垫圈 8	Washer	2	

### Z35A160201B 磁钢座 Seat

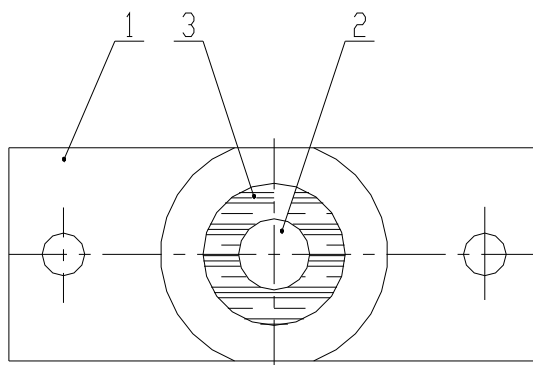

### Z35A160201B 磁钢座 Seat

序号	代 号	名 称		数量	备注
Item	Part No.	Parts Name		Q'ty	Remark
1	Z35A160201001B	磁钢座体	Seat	1	
2	Z35A160201002B	圆磁钢	Circular Alnico	1	
3		树脂粘结剂	Adhesive		

### Z38G1602T2 水平定位拉杆 Position Pole

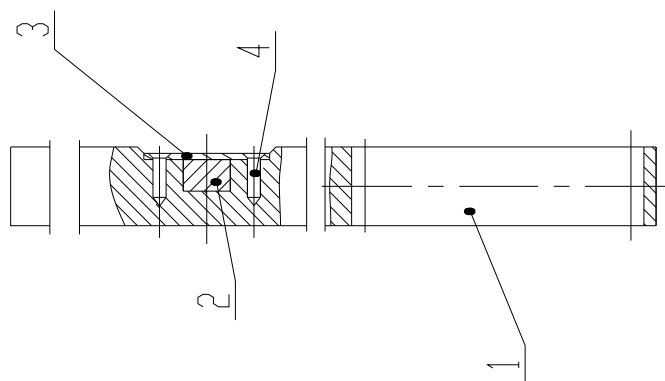

### Z38G1602T2 水平定位拉杆 Position Pole

序号	代 号	名 称		数量	备注
Item	Part No.	Parts Name		Q'ty	Remark
1	Z38G160200001T2	定位拉杆	Position Pole	1	
2	Z35A160201002B	圆磁钢	Circular Alnico	1	
3	Z50E160100002T56	盖	Cover	1	
4	GB/T954-1986	铆 4X15	Rivet	2	

空调系统  
**Air-conditioner System**



# Z38G17T2 空调系统 Air-conditioner System

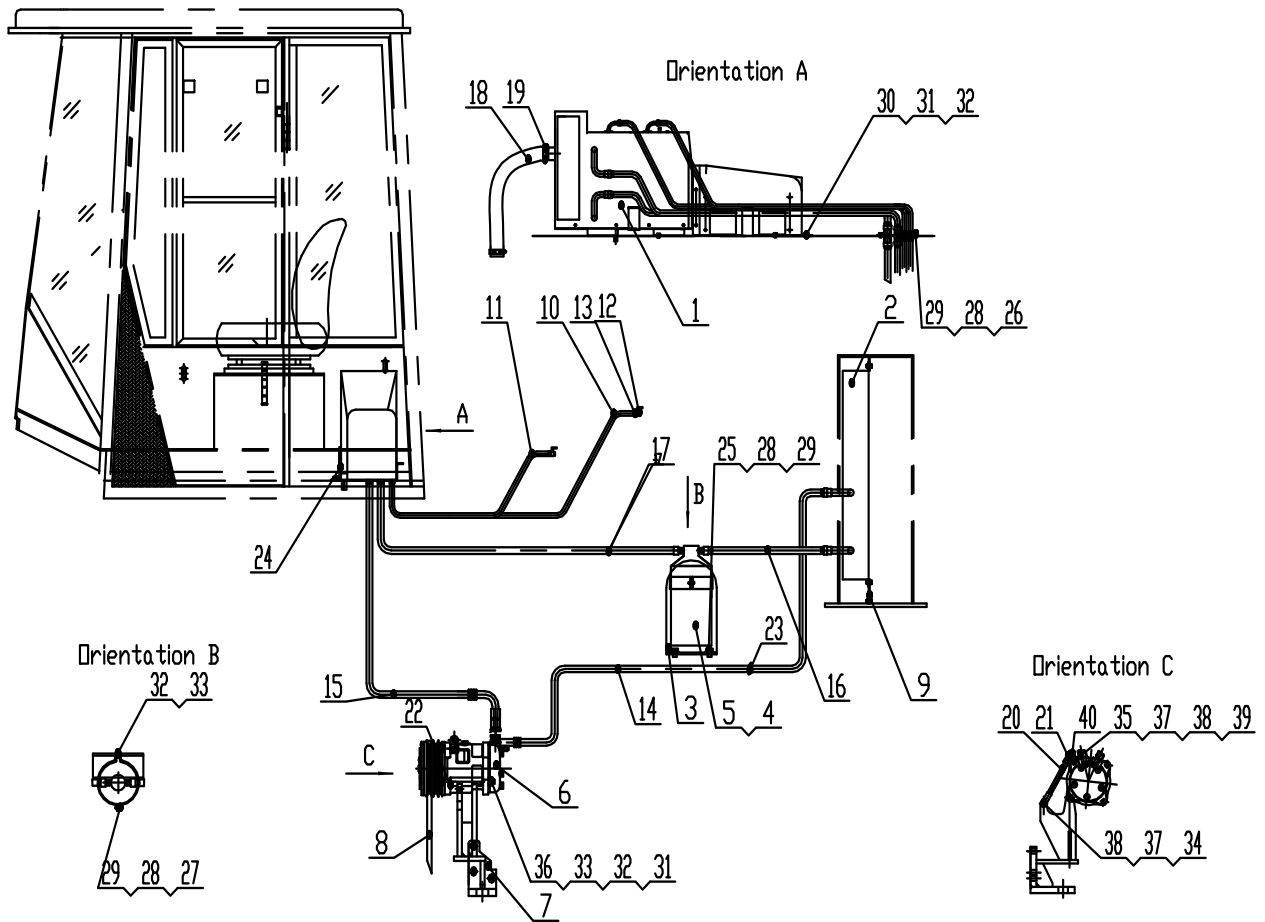

## Z38G17T2 空调系统 Air-conditioner System

序号 No.	代号 Part No.	名称 Parts Name		数量 Q'ty	备注 Remark
1	KQ2N3.0-CG2	蒸发器总成	Evaporator Assembly	1	
2	Z38G17000001T2	冷凝器总成	Condenser Assembly	1	
3	Z38G17000002T2	储液瓶支架	Storage Bottle Bracket	1	
4	HFC-R134a	制冷剂	R134a	1050ml	
5	Z38G17000003T2	储液瓶	Storage Bottle	1	
6	SE5H14/24V	压缩机	Compressor	1	
7	Z38G170101T2	压缩机支架	Compressor Bracket	1	
8	Z38G17000004T2	三角带	Three-cornered Strap	1	
9	Z38G1702T2	冷凝器支架	Condenser Bracket	1	
10	Z38G17000005T2	进水管	Inlet Pipe	1	
11	Z38G17000006T2	出水管	Outlet Pipe	1	
12	Z3/8	水阀	Valve	2	
13		喉箍 20-30	Hoop	4	
14	Z38G17000007T2	高压管	High Pressure Pipe	1	
15	Z38G17000008T2	低压管	Low Pressure Pipe	1	
16	Z38G17000009T2	冷凝器出口管	Condenser Outlet Pipe	1	
17	Z38G17000010T2	蒸发器进口管	Evaporator Inlet Pipe	1	
18	Z38G17000011T2	风管	Pipe	1	
19	Z38G17000012T2	卡箍	Hoop	2	
20	P165. 17. 1-2	调节螺杆	Adjustive screw	1	
21	Z35G130501003	调节座	Adjustive seat	1	
22	Z40F130501002T2	垫片	Washer	2 组	
23	ZD 200X8	扎带	Locking Cable Ties	20	
24	Z38G17000013T2	密封泡沫	Foam	1	
25	GB/T 5782-2000	螺栓 M6X16	Bolt M6X16	2	
26	GB/T 5782-2000	螺栓 M6X20	Bolt M6X20	4	
27	GB/T 5782-2000	螺栓 M6X30	Bolt M6X30	1	
28	GB/T 97. 1-2002	垫圈 6	Washer 6	7	
29	GB/T 93-1987	垫圈 6	Washer 6	7	
30	GB/T 5782-2000	螺栓 M8X25	Bolt M8X25	5	
31	GB/T 97. 1-2002	垫圈 8	Washer 8	5	
32	GB/T93-1987	垫圈 8	Washer 8	6	

## Z38G17T2 空调系统 Air-conditioner System

序号 No.	代 号 Part No.	名 称 Parts Name		数量 Q'ty	备 注 Remark
33	GB/T 6170-2000	螺母 M8	Nut M8	1	
34	GB/T 5783-2000	螺栓 M10X25	Bolt M10X25	7	
35	GB/T 5783-2000	螺栓 M10X40	Bolt M10X40	1	
36	GB/T 31.1-88	螺栓M10X130	Bolt M10X130	1	
37	GB/T 93-87	垫圈10	Washer 10	9	
38	GB/T 95-2002	垫圈10	Washer 10	15	
39	GB/T 6170-2000	螺母M10	Nut M10	6	
40	GB/T 6170-2000	螺母M12	Nut M12	2	

# **Z38G18 风扇控制系统**

## Fan Control System

# Z38G18 风扇控制系统 Fan Control System

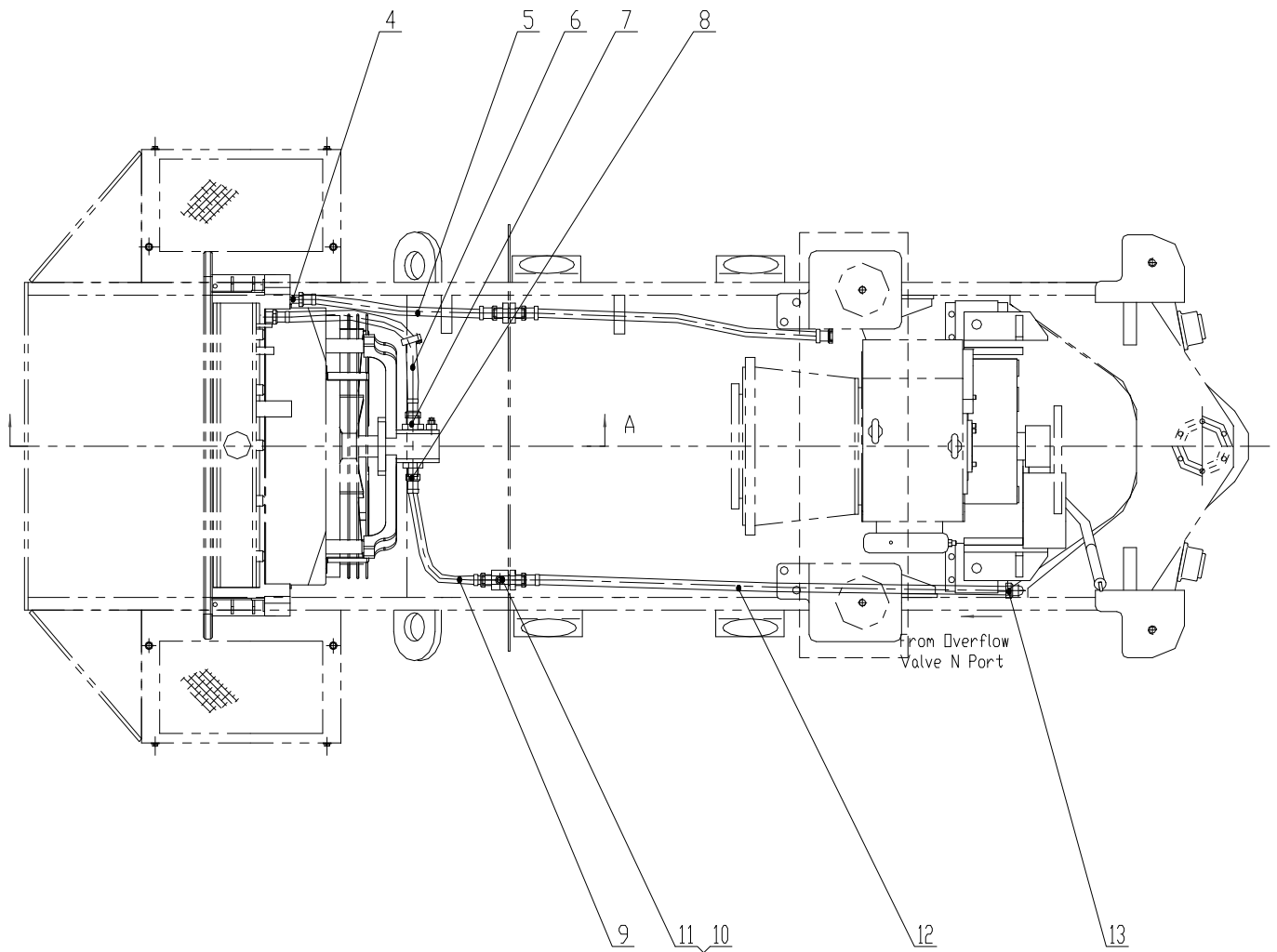
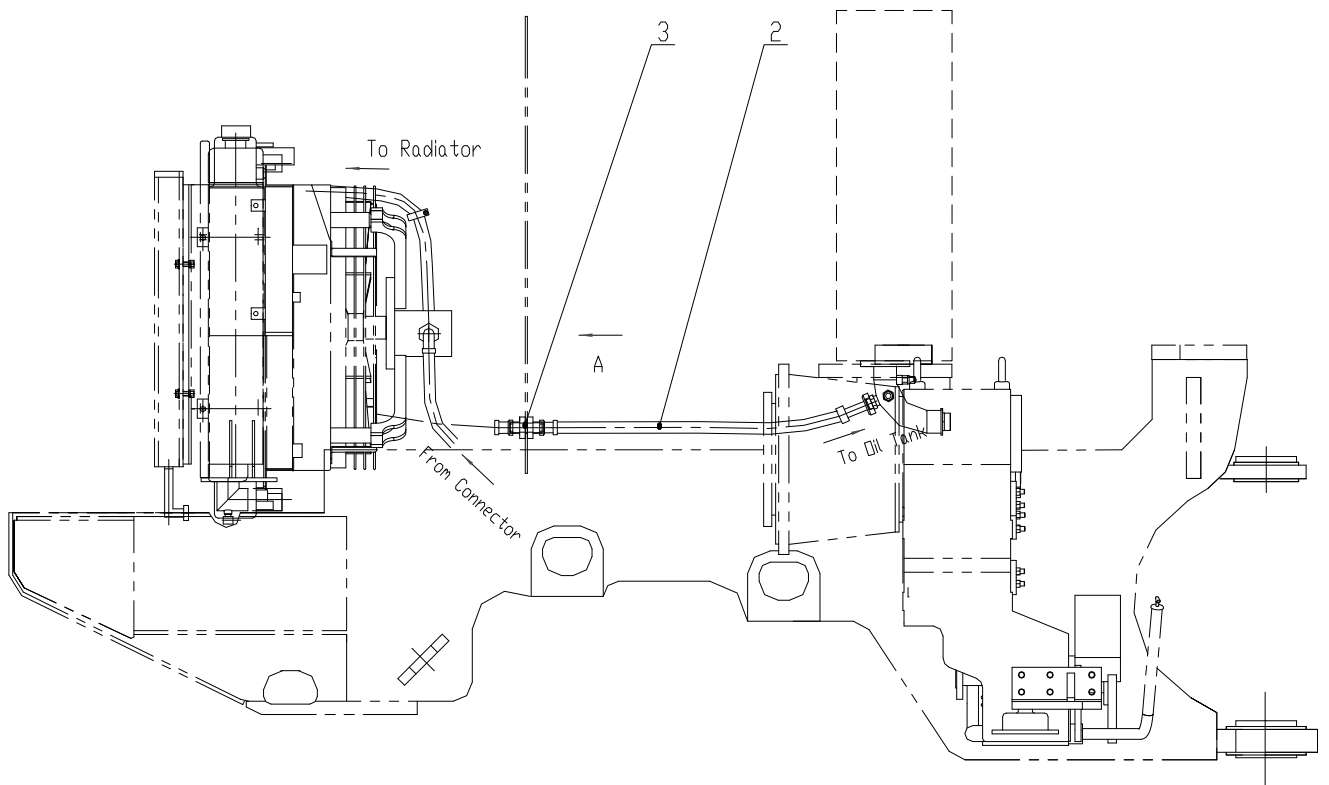

# Z38G18 风扇控制系统 Fan Control System

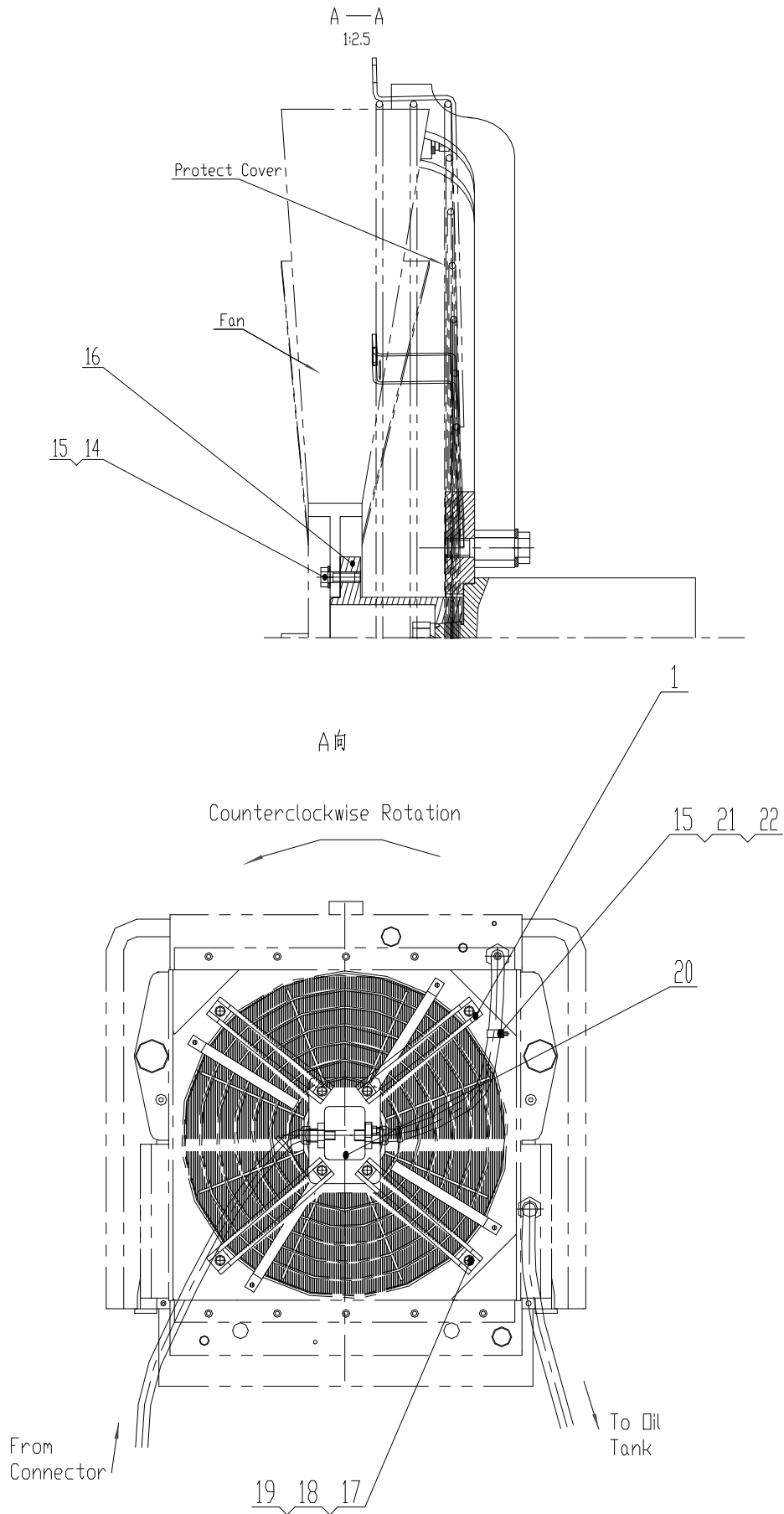

## Z38G18 风扇控制系统 Fan Control System

序号 No.	代 号 Part No.	名 称 Parts Name		数量 Q'ty	备 注 Remark
1	Z38G1801	马达支架总成	Motor Bracket Assembly	1	
2	20411-30-12Z/20441-30-12ZX1T12GTX1250	胶管	Hose	1	
3	6C-30LNZ	过板接头	Connector	1	
4	2C9-30Z	接头体	Connector	1	
5	20411-30-12Z/20441-30-12ZX1T12GTX510	胶管	Hose	1	
6	20411-30-12ZX1T12GTX840	胶管	Hose	1	
7	1CG-30-16Z	接头体	Connector	1	
8	1DG-30-12Z	接头体	Connector	1	
9	20511-30-12Z/20591-30-12TZX3T12GTX550	胶管	Hose	1	
10	4M-14WDZ	堵头	Plug	1	
11	KDMD-30-14-30FALNZ	过板接头	Connector	1	
12	20511-30-12Z/20591-30-12ZX3T12GTX2590	胶管	Hose	1	
13	2D9-30Z	接头体	Connector	1	
14	GB/T5783-2000	螺栓 M8X20	BoltM8X20	5	
15	GB/T93-1987	垫圈 8	Washer8	6	
16	Z50G180000002T17	连接盘	Plate	1	
17	GB/T5782-2000	螺栓 M12X50	Bolt 12X50	4	
18	GB/T93-1987	垫圈 12	Washer12	4	
19	GB/T97.1-2002	垫圈 12	Washer12	4	
20	WM09A1C230R07TB122HGNNR2320001M	液压马达	Hydraulic Motor	1	右旋 Right
21	K0608-29Z	φ 29 管夹	Clip φ 29	1	
22	GB/T5783-2000	螺栓 M8X16	BoltM8X16	1	

## Z38G1801 马达支架总成 Motor Bracket Assembly

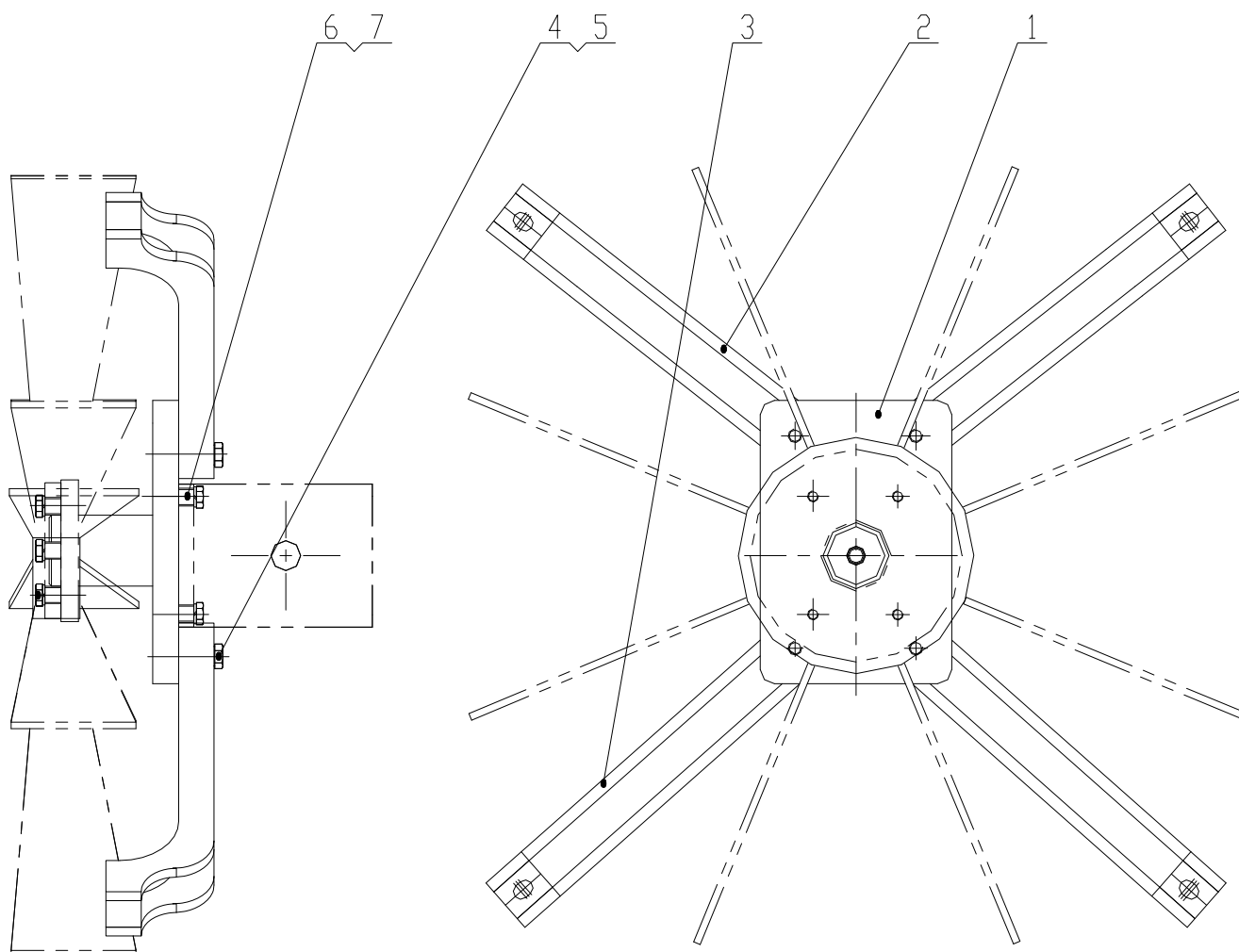

## Z38G1801 马达支架总成 Motor Bracket Assembly

序号 Item	代 号 Part No.	名 称 Parts Name	数量 Q'ty	备注 Remark
1	Z50G180100001T7	安装板 Plate	1	
2	Z38G180101	上连接辐板总成 Plate Assembly	2	
3	Z38G180102	下连接辐板总成 Plate Assembly	2	
4	GB/T5783-2000	螺栓 M14x50 BoltM14X50	4	
5	GB/T93-1987	垫圈 14 Washer14	4	
6	GB/T5783-2000	螺栓 M8x35 BoltM8X35	4	
7	GB/T93-1987	垫圈 8 Washer8	4	



# 提升臂架支承装置

The safety support of lift cylinder

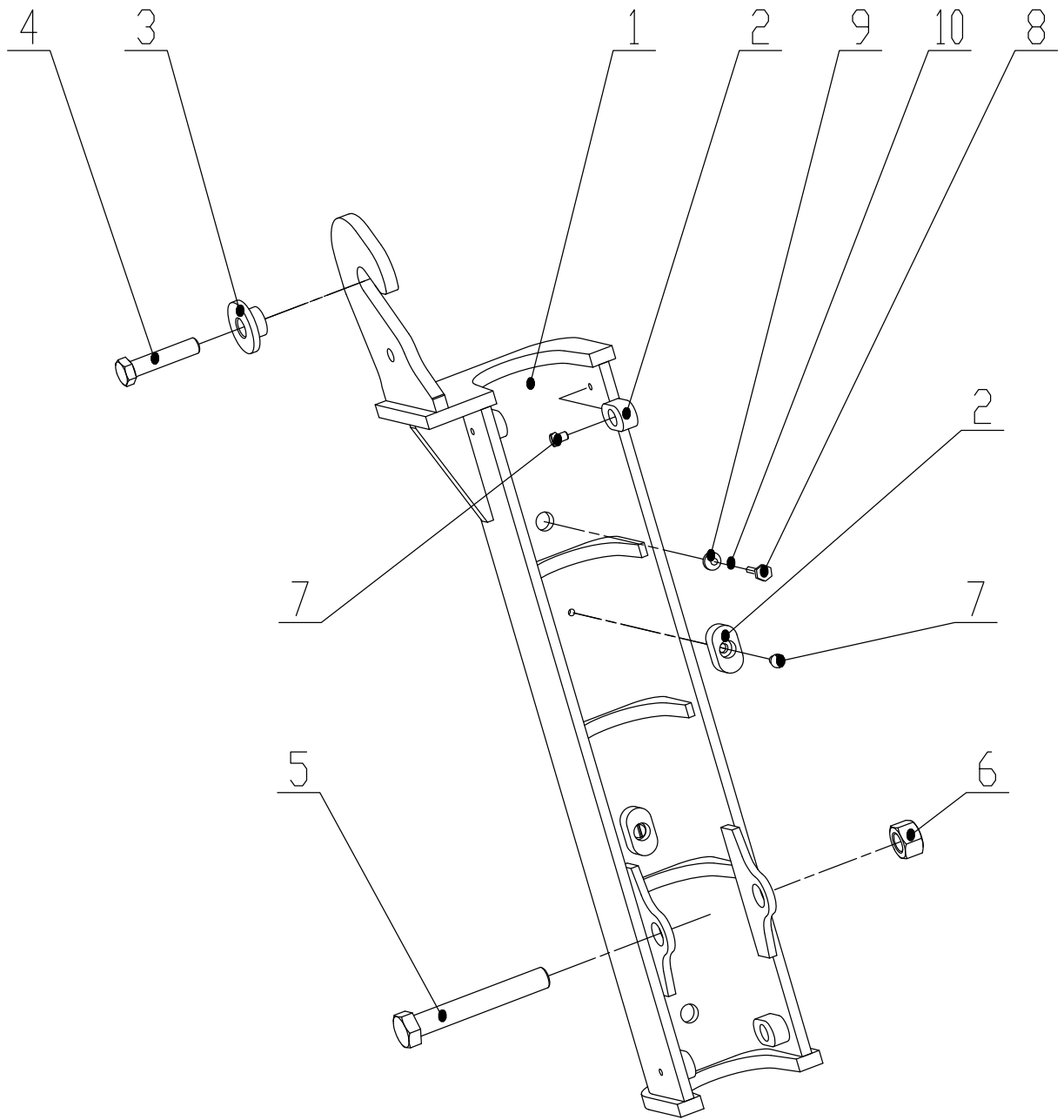

Z38G19T1 提升臂架支承装置 The safety support of lift cylinder

序号 Item	代号 Part No.	名 Parts	称 Name	数量 Q'ty	备注 Remark
1	Z38G1901T1	油缸保护杆	The Safety Support	1	
2	Z50E120902002	减震垫	Seal Ring 90X104	6	
3	Z35G190000001T4	过渡套	Bushing	1	
4	GB/T 5783-2000	螺栓 M12X55 8.8	Bolt M12X55 8.8	1	
5	GB/T 5780-2000	螺栓 M16x110 4.8	Bolt M16x110 4.8	1	
6	GB/T 6170-2000	螺母 M16 8	Nut M16 8	1	
7	GB/T 65-2000	螺钉 M6 x 16 4.8	Bolt M6 x 16 4.8	6	
8	GB/T5783-2000	螺栓 M12x30 8.8	Bolt M12x30 8.8	2	
9	GB/T 97.1-2002	垫圈 12 140HV	Washer 12 140HV	2	
10	GB/T 93-1987	垫圈 12 65Mn	Washer 12 65Mn	2	

# 手动集中润滑油路系统

## Manual Centralized Lubricating System

**Z38G21T1 手动集中润滑油路系**  
**Manual Centralized Lubricating System**

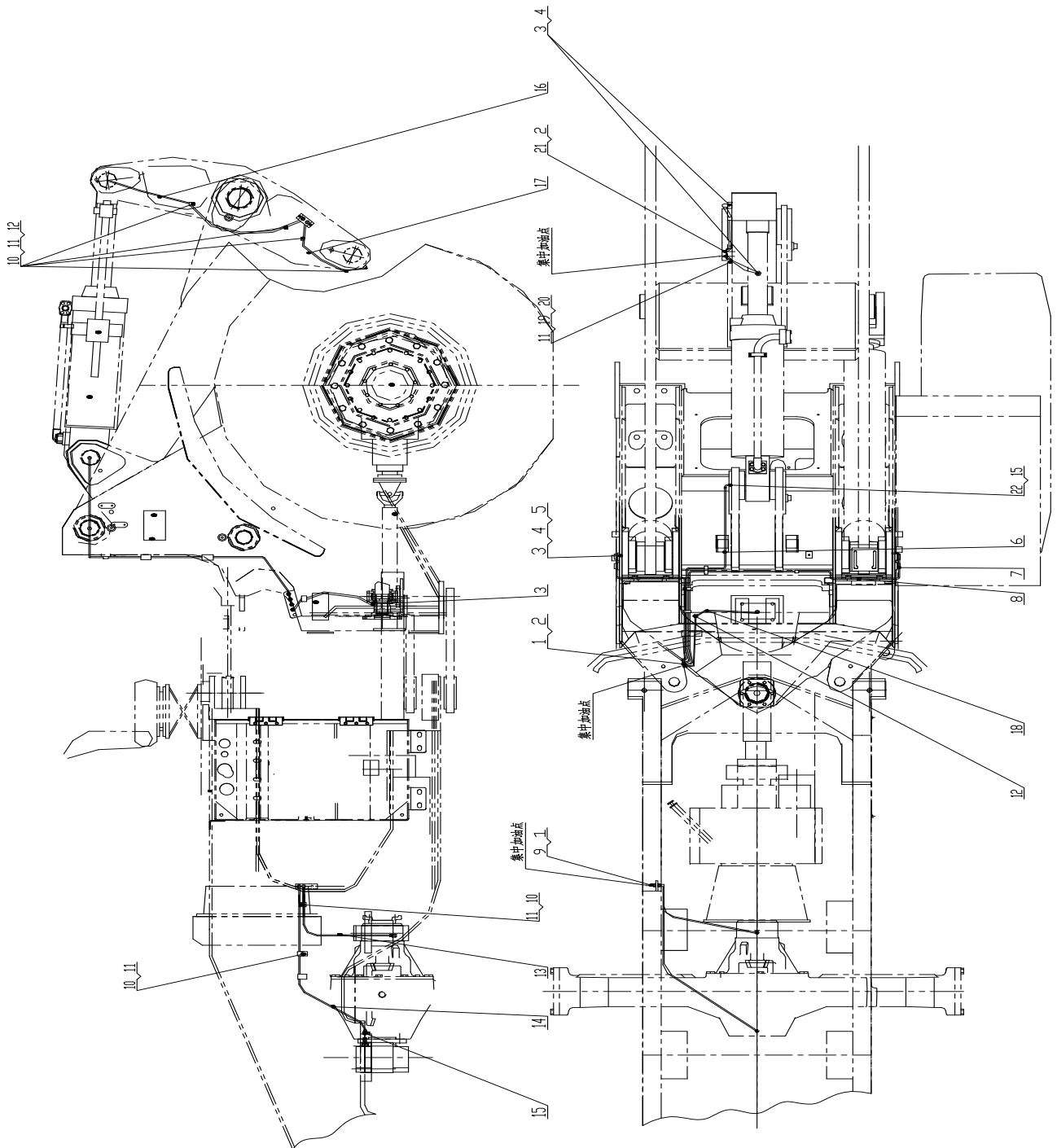

**Z38G21T1手动集中润滑油路系统**  
**Manual Centralized Lubricating System**

序号 Item	代号 Part No.	名 称 Parts Name	数量 Q'ty	备注 Remark
1	5QM-12C-10LALNZ	接头 Connector	6	
2	JB/T7940.1-1995	油杯M10X1 Oil Cup M10X1	6	
3	1QH-12C(1.25)-10(六方L=20)Z	接头 Connector	5	
4	2Q9-12C (1.25) Z	接头 Connector	4	
5	Z38G2101T1	润滑管1 Lubricate Conduit1	1	
6	Z38G2102T1	润滑管2 Lubricate Conduit2	1	
7	Z38G2103T1	润滑管3 Lubricate Conduit3	1	
8	K0608-06Z	管夹 Clamp	10	
9	JB/T7940.2-1995	油杯M10X1 Oil Cup M10X1	2	
10	GB/T 5783-2000	螺栓M8X16 Bolt M8X16	14	
11	GB/T 93-1987	垫圈8 Washer8	14	
12	K0608-12Z	管夹 Clamp	4	
13	Z38G2107T1	润滑管7 Lubricate Conduit7	1	
14	Z38G2108T1	润滑管8 Lubricate Conduit8	1	
15	1QH9-12C-10OGZ	接头 Connector	3	
16	Z38G2104T1	树脂润滑管总成1 Lubricate Conduit	1	
17	Z38G2105T1	树脂润滑管总成2 Lubricate Conduit	1	
18	Z38G2106T1	树脂润滑管总成3 Lubricate Conduit	1	
19	Z50G210000001T15	支架 Supporting plate	1	
20	GB/T 70.1-2000	螺栓M8X20 Bolt M8X20	2	
21	5QM9-12C-10FALNZ	接头 Connector	2	
22	5HN-10FAZ	接头 Connector	1	
23	1QH9-12-10Z	接头 Connector	12	